

Linear Slide Cylinder LCX Series

LINEAR SLIDE CYLINDER LCX SERIES

NEW

Position locking type and
long stroke are added!



Thinness, lightness, rigidity

Additional option variations cover a wider scope of use.

Thin

The thinness in every part of the product reduced the LCG height of 60 mm down to 34 mm! Best suited for space saving applications.

The height of cylinder is 43% less than the conventional model.

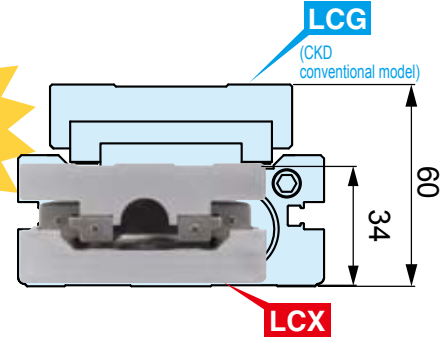

Light

Half the product weight of conventional LCG! The light-weight movable part enables reduced production time and energy consumption.

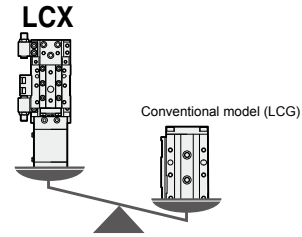

Rigid

Separate-type linear guide is employed. Thin and light weight, with the same rigidity as the conventional model (LCG).

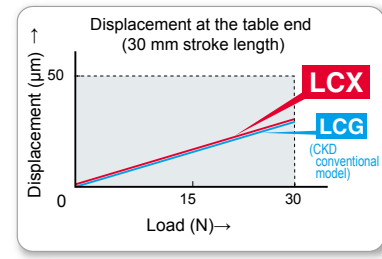

Wide variation

Center stoppers are also available (custom order). The stopper at the stroke end does not produce moment, restricting miss-alignment to the minimum.

Symmetric design. Mounting is possible on the left and right of the pipe and stopper. ← indicates the piping direction.

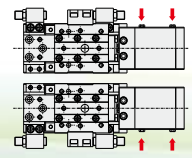

T-shape switch is employed. Proximity 2-color indicator switch is available.



Rust proof type. Rust proof finish is provided as standard.

Various stopper options



LCGX Series

Linear slide cylinder

Unitization promotes simplicity, certainty, and precision.

Attractive, rich options including flexible combination, the position locking type, long stroke type (Max. 150 mm), and the dowel hole. The wider scope of use in conveyance and positioning will add to efficient multi-product manufacturing.

High precision positioning mechanism

The accurate dowel hole and the specialized bolt having **positioning mechanism** realize direct mounting without position adjustment.

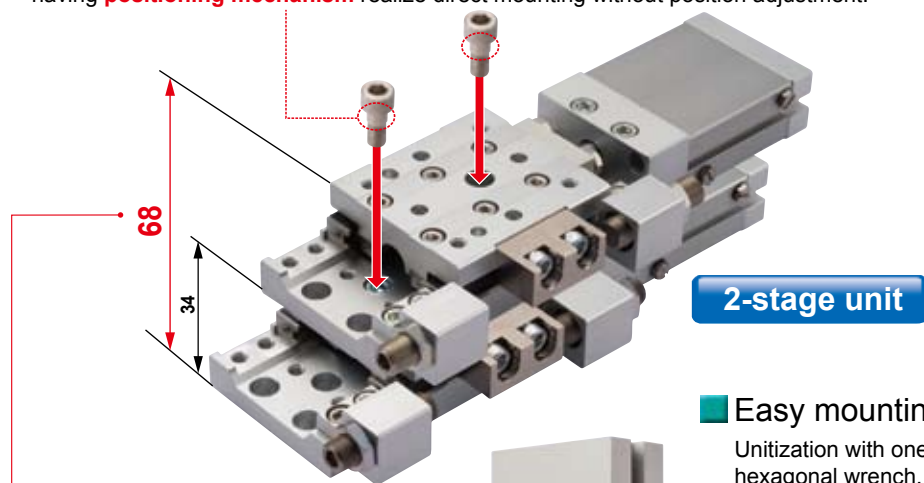

As thin as 68 mm even when stacked

Direct mounting without a connection plate realizes the thinness of the product.

Easy mounting

Unitization with one hexagonal wrench.



High-rigidity, wide guide

Equivalent to a 42 mm wide rail.



Significant reduction of maintenance time

The cylinder section can be replaced while the body being kept mounted on the equipment.

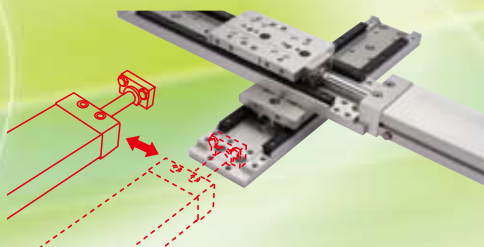

LCX product variation

LCX

Double acting
single rod type



Φ25, Φ32
stroke: 10 to 50 mm

LCX-Q

Double acting
position locking type

New

Φ25, Φ32
stroke: 10 to 50 mm



LCX-P7*

Double acting / single rod
type clean room
specifications

Φ25, Φ32
stroke: 10 to 50 mm

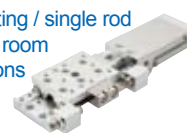

LCX-*L

Double acting / single rod
long stroke

New

Φ25, Φ32
stroke: 75 to 150 mm



LCX-Q-*L

Double acting / position locking
type long stroke

New

Φ25, Φ32
stroke: 75 to 150 mm



LCX-*L-P7*

Double acting / single rod type /
clean room specifications long stroke

New

Φ25, Φ32
stroke: 75 to 150 mm



Series variation

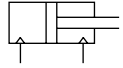
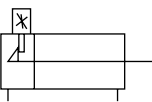
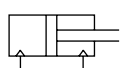
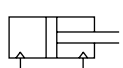
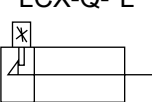
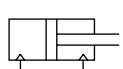

Linear slide cylinder LCX Series

Variation	Model number JIS symbol	Bore size (mm)	Stroke length (mm)										
			10	20	30	40	50	75	100	125		150	
Double acting single rod type	LCX 	ø25/ø32	●	●	●	●	●						
Double acting position locking type	LCX-Q 	ø25/ø32	●	●	●	●	●						
Double acting single rod type clean room specifications	LCX-P7* 	ø25/ø32	●	●	●	●	●						
Double acting single rod type long stroke	LCX-*L 	ø25/ø32							●	●	●	●	
Double acting position locking type long stroke	LCX-Q-*L 	ø25/ø32							●	●	●	●	
Double acting single rod type clean room specifications long stroke	LCX-*L-P7* 	ø25/ø32							●	●	●	●	

●: Standard ◎: Option ○: Available ■: Not available

		Option																With dowel hole	Center type stopper	Switch	Page			
		Rubber cushion type stopper						Metal type stopper						Shock absorber type stopper										
		Stopper position (1)	Stopper position (2)	Stopper position (3)	Stopper position (4)	Stopper position (1)/(3)	Stopper position (2)/(4)	Stopper position (1)	Stopper position (2)	Stopper position (3)	Stopper position (4)	Stopper position (1)/(3)	Stopper position (2)/(4)	Stopper position (1)	Stopper position (2)	Stopper position (3)	Stopper position (4)					Stopper position (1)/(3)	Stopper position (2)/(4)	
		S1	S2	S3	S4	S5	S6	M1	M2	M3	M4	M5	M6	A1	A2	A3	A4	A5	A6	E	Note 1			
		◎	◎	◎	◎	◎	◎	◎	◎	◎	◎	◎	◎	◎	◎	◎	◎	◎	◎	◎	◎	○	◎	1
		◎	◎	■	■	■	■	◎	◎	■	■	■	■	◎	◎	■	■	■	■	◎	◎	◎	◎	11
		◎	◎	◎	◎	◎	◎	◎	◎	◎	◎	◎	◎	■	■	■	■	■	■	◎	◎	◎	◎	17
		◎	◎	◎	◎	◎	◎	◎	◎	◎	◎	◎	◎	◎	◎	◎	◎	◎	◎	◎	●	○	◎	23
		◎	◎	■	■	■	■	◎	◎	■	■	■	■	◎	◎	■	■	■	■	◎	◎	◎	◎	33
		◎	◎	◎	◎	◎	◎	◎	◎	◎	◎	◎	◎	■	■	■	■	■	■	◎	◎	◎	◎	39

Note 1: Center type stopper is a custom order product. Consult with CKD for details.

● Stopper position

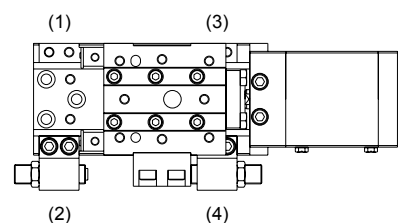

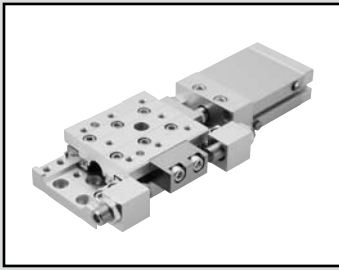

Linear slide cylinder double acting / single rod type

LCX Series

● Bore size: $\varnothing 25/\varnothing 32$

JIS symbol

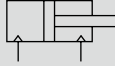

Specifications

Descriptions		LCX	
		$\varnothing 25$	$\varnothing 32$
Bore size	mm		
Actuation		Double acting	
Working fluid		Compressed air	
Max. working pressure	MPa	0.7	
Min. working pressure	MPa	0.15	
Withstanding pressure	Mpa	1.05	
Ambient temperature	°C	-10 to 60 (not freezing) (Note 1)	
Port size		M5	
Stroke tolerance	mm	+2.0 0 (Note 2)	
Working piston speed	mm/s	20 to 500 (Note 3)	
Cushion		Rubber cushioned	
Lubrication		Not available	
Allowable energy absorption J		Refer to table 3 on Page 46.	

Note 1: Please consult us if you use the instrument in an environment of constantly low (5°C or less) or high (40°C or over) temperature.

Note 2: When not using a stopper, a slight gap may exist between the end plate and floating bushing.

Note 3: Use the metal stopper between 20 and 200 mm/s.

Stroke length

Bore size (mm)	Standard stroke length (mm)
$\varnothing 25$	10, 20, 30, 40, 50
$\varnothing 32$	10, 20, 30, 40, 50

Note: Stroke length other than above is not available.

Switch specifications

* The T0/T5 switch can be used with 220 VAC.
Contact CKD for working conditions.

- 1/2 color indicator

Descriptions	Reed 2 wire				Proximity 2 wire		Proximity 3 wire	
	T0H/T0V		T5H/T5V		T2H/T2V	T2WH/T2WV	T3H/T3V	T3WH/T3WV
Applications	Programmable controller, relay		Programmable controller, relay, IC circuit (w/o light), serial connection		Programmable controller		Programmable controller, relay	
Output method	-		-		-		NPN output	
Power voltage	-		-		-		10 to 28 VDC	
Load voltage	12/24 VDC	110 VAC	5/12/24 VDC	110 VAC	10 to 30 VDC	24 VDC ± 10%	30 VDC or less	
Load current	5 to 50 mA	7 to 20 mA	50 mA or less	20 mA or less	5 to 20 mA		100 mA or less	50 mA or less
Light	LED (ON lighting)		Without indicator light		LED (ON lighting)	Red/green LED (ON lighting)	LED (ON lighting)	Red/green LED (ON lighting)
Leakage current	0 mA				1 mA or less		10 µA or less	

Cylinder weight

- Basic type

(Unit: g)

Bore size (mm)	Basic type stroke length (mm)				
	10	20	30	40	50
ø25	980	1,010	1,030	1,150	1,170
ø32	1,000	1,030	1,050	1,180	1,200

- Additional weight for options

(Unit: g)

Bore size (mm)	Option stopper symbol					
	S1 to S4	M1 to M4	A1 to A4	S5/S6	M5/M6	A5/A6
ø25	170			240		
ø32	170			240		

Secondary battery specifications

LCX - ... -

P4*

- Design applicable for LiB manufacturing process

* Consult with CKD for details.

How to order

Without switch



With switch



Model No.

A Bore size

B Stroke length

C Switch model no.

F Option

D Switch quantity

E Stopper

⚠ Note on model no. selection

Note 1: Use a discrete rubber cushion type stopper or a metal type stopper on page 5 when changing the adjustable stroke range.

Note 2: When using a shock absorber, refer to the stopper dimensions table on page 10 for the adjustable stroke range.

Note 3: When using a metal type stopper, stopper block material copper alloy (symbol: T) is recommended.

Note 4: When a rubber cushion type stopper or a metal type stopper is used in combination with a shock absorber type stopper, they are provided for each custom order.

Note 5: Use the metal stopper between 20 and 200 mm/s.

Note 6: Selectable only when using a stopper type.

Note 7: A5* and A6* cannot be selected for 10-stroke cases.

Note 8: Positioning hole for assembling a cross unit or a 2-stage unit without position adjustment. Use it together with a positioning bolt (page 6).

Note 9: Refer to page 6 for cylinder model numbers.

<Example of model number>

LCX-25-40-T2H-R-A1T E

Model: Linear slide cylinder double acting / single rod type LCX

- A** Bore size : ø25
- B** Stroke : 40 mm
- C** Switch model no.: Proximity, 2-wire type
Axial lead wire
- D** Switch quantity : With one pc. on rod end
- E** Stopper : Shock absorber type stopper
Stopper position (1)
Material, alloy steel (nitriding)
- F** Option : Dowel hole

● Stopper position

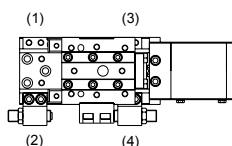

Symbol	Descriptions			
A Bore size				
25	ø25			
32	ø32			
B Stroke length (mm)				
10	10			
20	20			
30	30			
40	40			
50	50			
C Switch model no.				
Axial lead wire	Radial lead wire	Contact	Indicator	Lead wire
T0H*	T0V*	Reed	One color indicator type	2-wire
T5H*	T5V*		Without indicator light	
T2H*	T2V*	Proximity	One color indicator type	2-wire
T3H*	T3V*		Two color indicator type	3-wire
T2WH*	T2WV*		Two color indicator type	2-wire
T3WH*	T3WV*		Two color indicator type	3-wire
* Lead wire length				
Blank	1 m (standard)			
3	3 m (option)			
5	5 m (option)			
D Switch quantity				
R	One on rod end			
H	One on head end			
D	Two			
E Stopper				
Blank	Without stopper			
S: Rubber cushion type stopper Note 1, Note 4				
S1*	Stopper position (1) (can be changed to (4))			Stopper installation position
S2*	Stopper position (2) (can be changed to (3))			
S3*	Stopper position (3) (can be changed to (2))			
S4*	Stopper position (4) (can be changed to (1))			
S5*	Stopper position (1), (3)			
S6*	Stopper position (2), (4)			
M: Metal type stopper Note 1, Note 3, Note 4, Note 5				
M1*	Stopper position (1) (can be changed to (4))			Stopper installation position
M2*	Stopper position (2) (can be changed to (3))			
M3*	Stopper position (3) (can be changed to (2))			
M4*	Stopper position (4) (can be changed to (1))			
M5*	Stopper position (1), (3)			
M6*	Stopper position (2), (4)			
A: Shock absorber type stopper Note 2, Note 4, Note 7				
A1*	Stopper position (1) (can be changed to (4))			Stopper installation position
A2*	Stopper position (2) (can be changed to (3))			
A3*	Stopper position (3) (can be changed to (2))			
A4*	Stopper position (4) (can be changed to (1))			
A5*	Stopper position (1), (3)			
A6*	Stopper position (2), (4)			
* Section				
Blank	Material of stopper block: Rolled steel			
T	Material of stopper block: Alloy steel (nitriding) Note 6			
F Option				
Blank	No options			
E	Dowel hole			Note 8

How to order switch

SW - T2H3

Switch model no.
(© on Page 3)

How to order stopper set

- A set of a stopper section and a rubber cushion stopper, a metal type stopper, or a shock absorber stoppers
- Used when changing from the standard to a rubber cushion stopper, a metal type stopper, or a shock absorber stopper

LCX - 25 - S 2 - S02

Bore size
(A on Page 3)

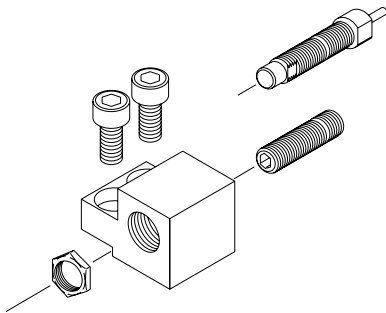

A Stopper type	
S	Rubber cushion type stopper
M	Metal type stopper
A	Shock absorber type stopper
B Stopper installation position	
1	For stopper position (1) or (4)
2	For stopper position (2) or (3)
C Adjustable stroke length Note 1	
Blank	Adjustable stroke range 10 mm
S02	Adjustable stroke range 20 mm

Note 1: Not selectable for shock absorber type stopper "A".

How to order rubber cushion type stopper

- Hexagon socket head set screw with urethane rubber
- Use for changing the adjustable stroke range or setting to the middle stroke

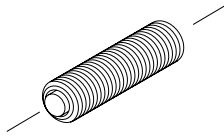

LCX - 25 - S02

Bore size
(A on Page 3)

A Adjustable stroke range	
S01	Single 10 mm (standard)
S02	Single 20 mm

How to order discrete metal type stopper

- Use for changing the adjustable stroke range or setting to the middle stroke

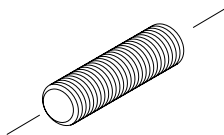

LCX - 25 - M02

Bore size
(A on Page 3)

A Adjustable stroke range	
M01	Single 10 mm (standard)
M02	Single 20 mm

How to order the discrete shock absorber stopper

- A set of a shock absorber and a stopper cap
- Used when changing from a rubber cushion type or metal type stopper to a shock absorber type stopper

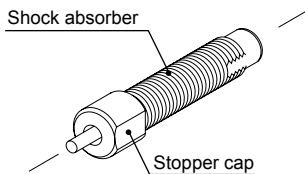

LCX - 25 - A01

Bore size
(A on Page 3)

Note: Refer to page 10 for the stroke adjustment range of the shock absorber type stopper.

Applicable shock absorber model No.

Model	Shock absorber model no.
LCX-25	NCK-00-1.2
LCX-32	NCK-00-1.2

How to order stopper block discrete part

- Used when changing from the standard to a rubber cushion type stopper, a metal type stopper, or a shock absorber stopper

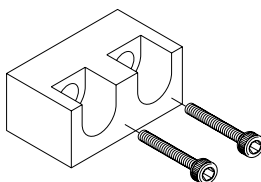

LCX - 25 - SB1 T

Bore size
(A on Page 3)

A Stopper block	
SB1	For 30 and 50 strokes
SB2	For 10, 20, and 40 strokes
B Material	
Blank	Material of stopper block: Rolled steel
T	Material of stopper block: Alloy steel (nitriding)

How to order the positioning bolt

- Hexagon socket head cap bolt with positioning mechanism
- Cross units and 2-stage units can be assembled without position adjustment.

LCX - 25 - J

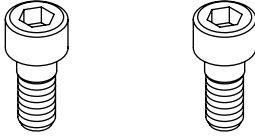

(2 pieces for each set)

How to order cylinder

LCX - CYL - 25 - 40

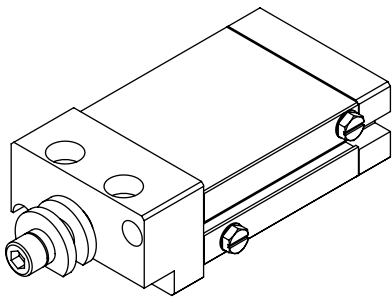

Bore size
(A on Page 3)

Stroke length
(B on Page 3)

Internal structure and parts list

● LCX

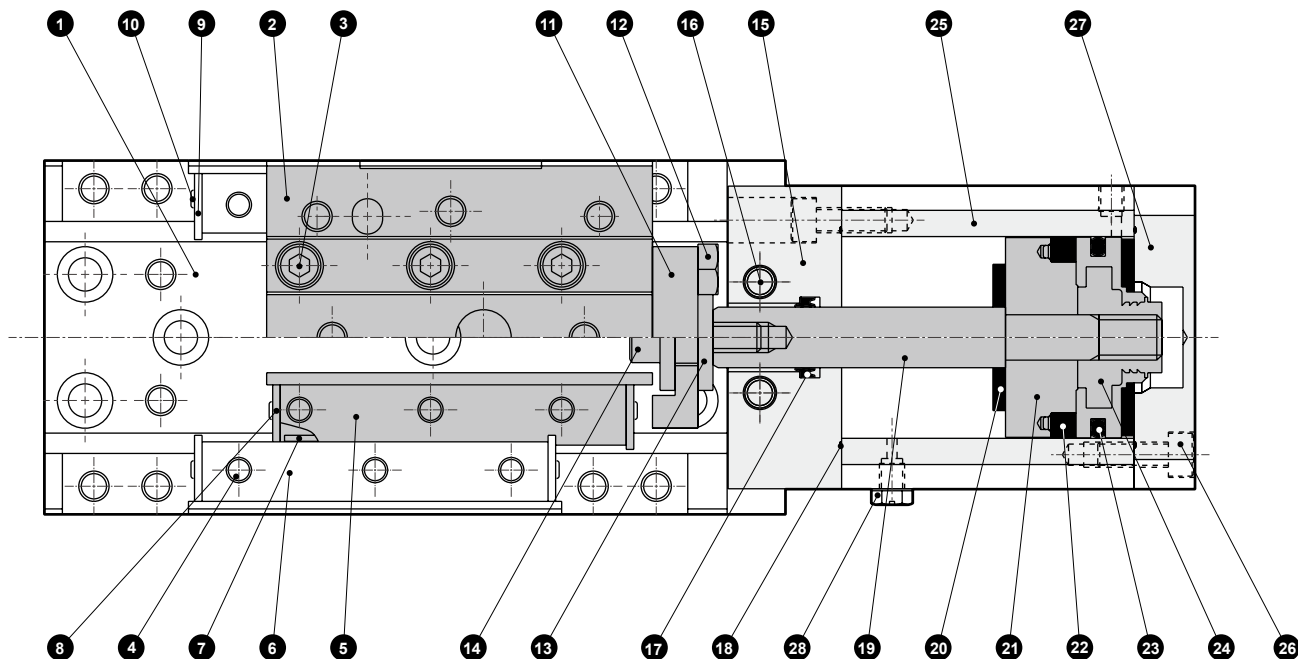

Parts list

No.	Parts name	Material	Remarks	No.	Parts name	Material	Remarks
1	Base	Aluminum alloy	Alumite	15	Rod cover	Aluminum alloy	Alumite
2	Table	Aluminum alloy	Alumite	16	Hexagon socket head cap bolt	Alloy steel	Zinc chromate
3	Hexagon socket head cap bolt	Stainless steel		17	Nod packing seal	Nitrile rubber	
4	Hexagon socket head cap bolt	Stainless steel		18	Gasket	Nitrile rubber	
5	Guide rail (1)	Alloy steel	Black chrome film	19	Piston rod	Alloy steel	Industrial chrome plated
6	Guide rail (2)	Alloy steel	Black chrome film	20	Cushion rubber	Urethane rubber	
7	Cage	Resin		21	Spacer	Aluminum alloy	
8	Stopper (1)	Stainless steel		22	Magnet	Plastic	
9	Stopper (2)	Stainless steel		23	Piston packing seal	Nitrile rubber	
10	Cross headed pan	Stainless steel		24	Piston	Aluminum alloy + polyacetal	
11	Plate	Aluminum alloy	Alumite	25	Cylinder body	Aluminum alloy	Hard alumite
12	Hexagon head bolt	Stainless steel		26	Hexagon socket head cap bolt	Alloy steel	Zinc chromate
13	Floating bush	Stainless steel		27	Head cover	Aluminum alloy	Alumite
14	Hexagon socket head cap bolt	Alloy steel	Zinc chromate	28	Plug	Brass	Nickeling

Repair parts list

Bore size (mm)	Kit no.	Repair parts number
ø25	LCX-25K	17 18
ø32	LCX-32K	20 23

Internal structure and parts list

Configuration with stopper

● Rubber cushion type stopper, metal type stopper

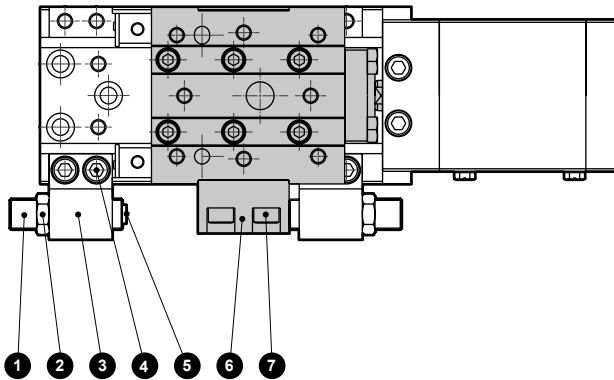

● Shock absorber type stopper

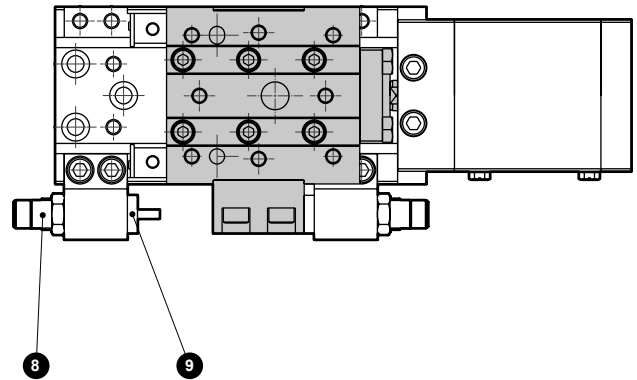

Parts list

No.	Parts name	Material	Remarks	No.	Parts name	Material	Remarks
1	Stopper bolt	Alloy steel	Nickeling	6	Stopper block (Stopper block symbol: blank)	Steel	Nickeling
2	Hexagon nut	Alloy steel	Zinc chromate		Stopper block (stopper block symbol: T)	Alloy steel	Nitriding
3	Stopper	Aluminum alloy	Alumite	7	Hexagon socket head cap bolt	Alloy steel	Zinc chromate
4	Hexagon socket head cap bolt	Alloy steel	Zinc chromate	8	Shock absorber		
5	Cushion rubber	Urethane rubber	Only rubber cushion type stopper	9	Stop cap	Stainless steel	

Dimensions

● Double acting single rod type LCX-25, 32

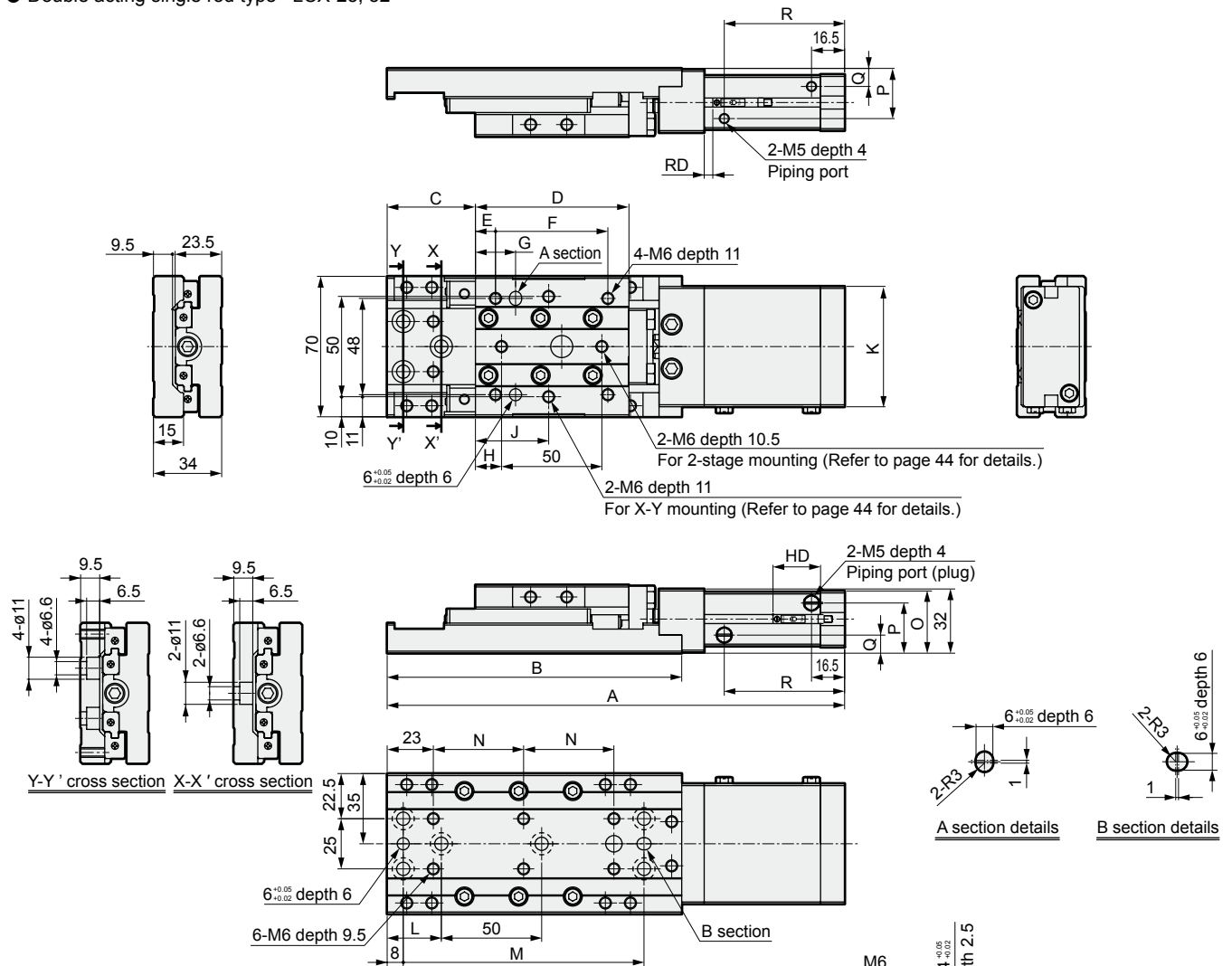

● With dowel hole LCX-25, 32-E

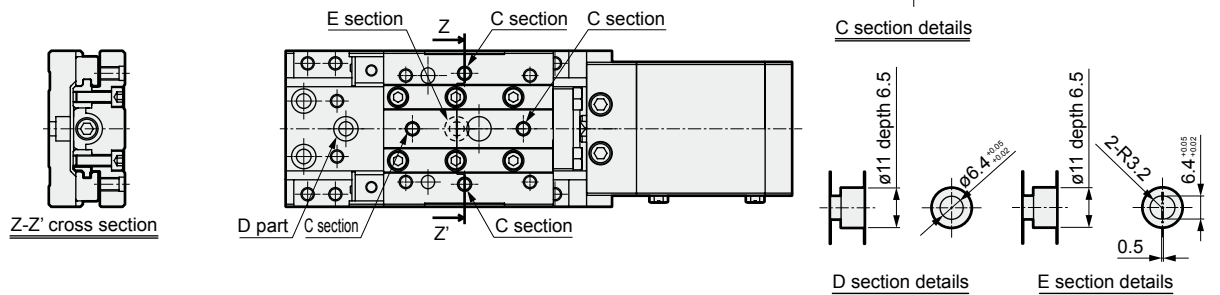

Bore size	Stroke length	A	B	C	D	E	F	G	H	J	K	L	M	N	O	P	Q	R	RD			HD		
																			T0*	T2*	T2W*	T0*	T2*	T2W*
																			T5*	T3*	T3W*	T5*	T3*	T3W*
ø25	10	208		34															40	5	6.5	23.5	21.5	
	20	218	147	39	76.5	10	56	20	13	36.5		27	120	45				50						
	30	228		44							50				29.5	24.5	9.5	60						
	40	258		49	86.5	15	64	30	23	46.5		41	140	55				70						
	50	268	167	54														80						
ø32	10	208		34															40	5	6.5	23.5	21.5	
	20	218	147	39	76.5	10	56	20	13	36.5		27	120	45				50						
	30	228		44							60				31	25	9	60						
	40	258		49	86.5	15	64	30	23	46.5		41	140	55				70						
	50	268	167	54														80						

Dimensions: option

- Rubber cushion type stopper (S1 to S6)

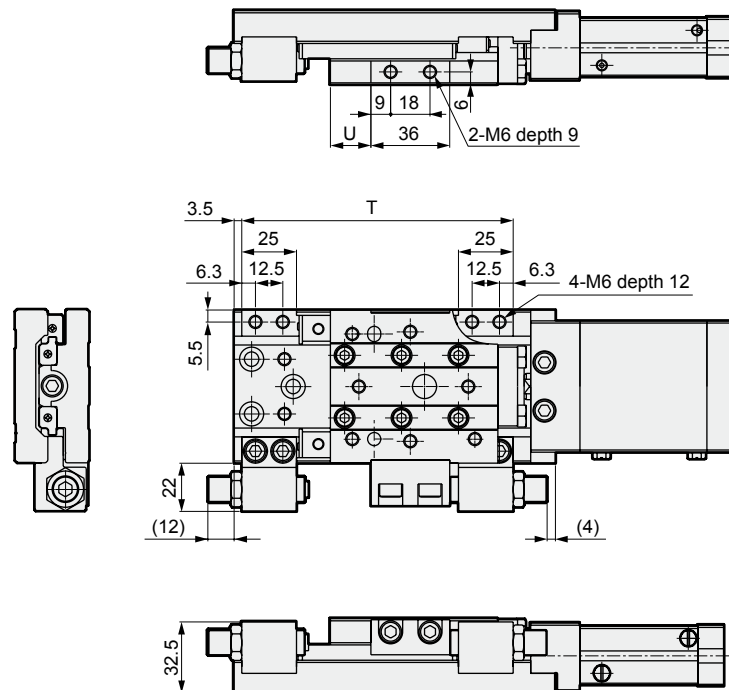

- Metal type stopper (M1 to M6)

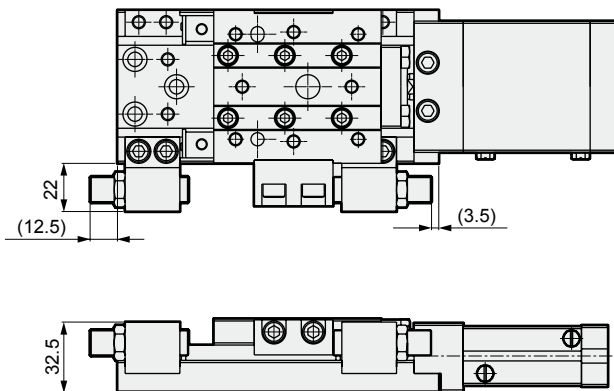

- Shock absorber type stopper (A1 to A6)

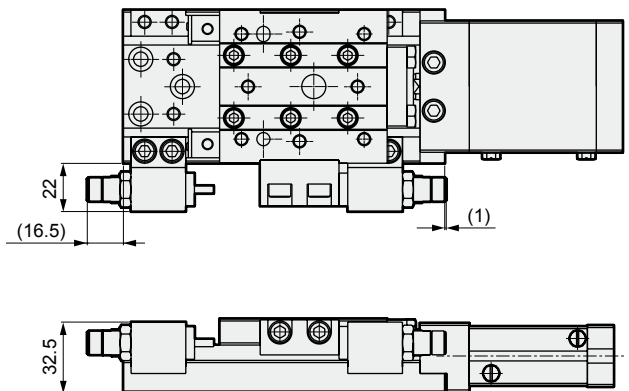

Note: If the adjustable stroke range is changed by the rubber cushion type stopper (S1 to S6) or metal type stopper (M1 to M6), the value within () will be changed accordingly.

Bore size	Stroke length	T	U	Adjustable stroke range (single)		
				Rubber cushion type stopper	Metal type stopper	Shock absorber type stopper
ø25	10	124	18.5	5	5	1
	20			10	10	7
	30					
	40	144	28.5	10	10	7
	50					
ø32	10	124	18.5	5	5	1
	20			10	10	7
	30					
	40	144	28.5	10	10	7
	50					

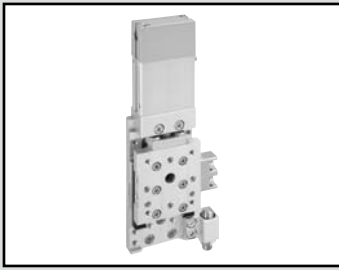

Linear slide cylinder double acting / single rod type / position locking type

LCX-Q Series

● Bore size: $\varnothing 25/\varnothing 32$

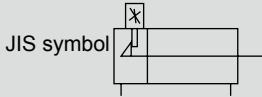

Specifications

Descriptions		LCX-Q	
Bore size	mm	$\varnothing 25$	$\varnothing 32$
Actuation		Double acting	
Working fluid		Compressed air	
Max. working pressure	MPa	0.7	
Min. working pressure	MPa	0.15	
Withstanding pressure	Mpa	1.05	
Ambient temperature	°C	-10 to 60 (not freezing) (Note 1)	
Port size		M5	
Stroke tolerance	mm	+2.0 0 (Note 2)	
Working piston speed	mm/s	20 to 500 (Note 3)	
Cushion		Rubber cushioned	
Position locking mechanism		Head end	
Holding force	N	130	230
Lubrication		Not available	
Allowable energy absorption	J	Refer to table 3 on Page 46.	

Note 1: Please consult us if you use the instrument in an environment of constantly low (5°C or less) or high (40°C or over) temperature.

Note 2: When not using a stopper, a slight gap may exist between the end plate and floating bushing.

Note 3: Use the metal stopper for adjusting the stroke between 20 and 200 mm/s.

Stroke length

Bore size (mm)	Standard stroke length (mm)
$\varnothing 25$	10, 20, 30, 40, 50
$\varnothing 32$	10, 20, 30, 40, 50

Note: Stroke length other than above is not available.

Switch specifications

* The T0/T5 switch can be used with 220 VAC.
Contact CKD for working conditions.

● 1/2 color indicator

Descriptions	Reed 2 wire				Proximity 2 wire		Proximity 3 wire	
	T0H/T0V		T5H/T5V		T2H/T2V	T2WH/T2WV	T3H/T3V	T3WH/T3WV
Applications	Programmable controller, relay		Programmable controller, relay, IC circuit (w/o light), serial connection		Programmable controller		Programmable controller, relay	
Output method	-		-		-		NPN output	
Power voltage	-		-		-		10 to 28 VDC	
Load voltage	12/24 VDC	110 VAC	5/12/24 VDC	110 VAC	10 to 30 VDC	24 VDC \pm 10%	30 VDC or less	
Load current	5 to 50 mA	7 to 20 mA	50 mA or less	20 mA or less	5 to 20 mA		100 mA or less	50 mA or less
Light	LED (ON lighting)		Without indicator light		LED (ON lighting)	Red/green-LED (ON lighting)	LED (ON lighting)	Red/green-LED (ON lighting)
Leakage current	0 mA				1 mA or less		10 μ A or less	

Cylinder weight

● Position locking type

(Unit: g)

Bore size (mm)	Basic type stroke length type (mm)				
	10	20	30	40	50
$\varnothing 25$	1,060	1,090	1,110	1,230	1,250
$\varnothing 32$	1,130	1,160	1,180	1,310	1,330

● Additional weight for options (stopper)

(Unit: g)

Bore size (mm)	Option stopper symbol		
	S1/S2	M1.M2	A1/A2
$\varnothing 25$	170		
$\varnothing 32$			

How to order

Without switch

LCX-Q - 25 - 40 ————— S5 E

With switch

LCX-Q - 25 - 40 - T2H* - R - S1T E

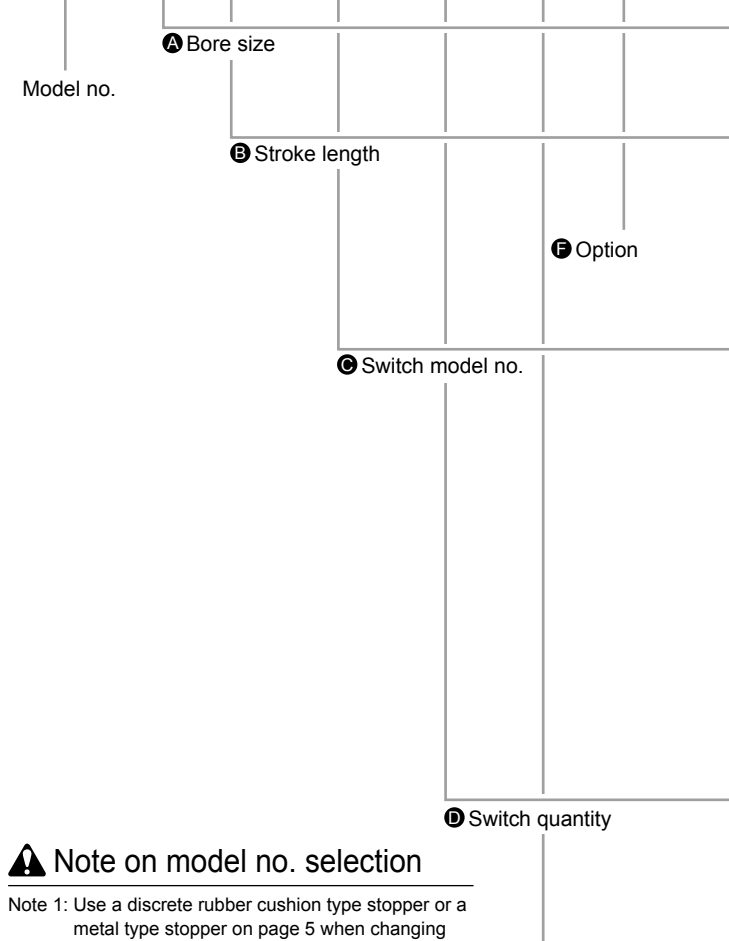

⚠ Note on model no. selection

- Note 1: Use a discrete rubber cushion type stopper or a metal type stopper on page 5 when changing the adjustable stroke range.
- Note 2: When using a shock absorber, refer to the stopper dimensions table on page 10 for the adjustable stroke range.
- Note 3: When using a metal type stopper, stopper block material copper alloy (symbol: T) is recommended.
- Note 4: When a rubber cushion type stopper or a metal type stopper is used in combination with a shock absorber type stopper, they are provided for each custom order.
- Note 5: Use it in 20 to 200 mm/s when used with a metal stopper.
- Note 6: Selectable only when using a stopper type.
- Note 7: The locking mechanism works at the stroke end. Do not mount it stopper positions (3) and (4).
- Note 8: Positioning hole for assembling a cross unit or a 2-stage unit without position adjustment. Use it together with a positioning bolt (page 6).
- Note 9: Refer to page 14 for cylinder model numbers.

<Example of model number>

LCX-Q-25-40-T2H-R-S1TE

Model: Linear slide cylinder double acting / position locking type LCX-Q

- A Bore size : $\varnothing 25$
- B Stroke : 40 mm
- C Switch model no. : Proximity, 2-wire type
Axial lead wire
- D Switch quantity : With one pc. on rod end
- E Stopper : Rubber cushion type stopper
Stopper position (1)
Material, alloy steel (nitriding)
- F Option : Dowel hole

● Stopper position

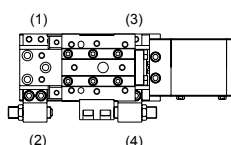

Symbol	Descriptions			
A Bore size				
25	$\varnothing 25$			
32	$\varnothing 32$			
B Stroke length (mm)				
10	10			
20	20			
30	30			
40	40			
50	50			
C Switch model no.				
Axial lead wire	Radial lead wire	Contact	Indicator	Lead wire
T0H*	T0V*	Reed	One color indicator type	2-wire
T5H*	T5V*		Without indicator light	
T2H*	T2V*	Proximity	One color indicator type	2-wire
T3H*	T3V*		Two color indicator type	3-wire
T2WH*	T2WV*		Two color indicator type	2-wire
T3WH*	T3WV*		Two color indicator type	3-wire
*Lead wire length				
Blank	1 m (standard)			
3	3 m (option)			
5	5 m (option)			
D Switch quantity				
R	One on rod end			
H	One on head end			
D	Two			
E Stopper				
Blank	Without stopper			
S: Rubber cushion type stopper Note 1, Note 4, Note 7				
S1*	Stopper position (1)			Stopper installation position
S2*	Stopper position (2)			
M: Metal type stopper Note 1, Note 3, Note 4, Note 5, Note 7				
M1*	Stopper position (1)			Stopper installation position
M2*	Stopper position (2)			
A: Shock absorber type stopper Note 2, Note 4, Note 7				
A1*	Stopper position (1)			Stopper installation position
A2*	Stopper position (2)			
* Section				
Blank	Material of stopper block: Rolled steel			
T	Material of stopper block: Alloy steel (nitriding) Note 6			
F Option				
Blank	No option			
E	Dowel hole			Note 8

How to order switch

SW - T2H3

Switch model no.
(© at page 12)

How to order stopper set

- A set of a stopper section and a rubber cushion stopper, a metal type stopper, or a shock absorber stoppers
- Used when changing from the standard to a rubber cushion stopper, a metal type stopper, or a shock absorber stopper

LCX - 25 - S 2 - S02

Bore size
(A at page 12)

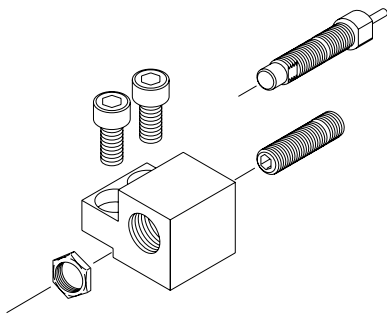

Note 1: Not selectable for shock absorber type stopper "A".

A Stopper type	
S	Rubber cushion type stopper
M	Metal type stopper
A	Shock absorber type stopper
B Stopper installation position	
1	Stopper position (1)
2	Stopper position (2)
C Adjustable stroke length Note 1	
Blank	Adjustable stroke range 10 mm
S02	Adjustable stroke range 20 mm

How to order rubber cushion type stopper

- Hexagon socket head set screw with urethane rubber
- Use for changing the adjustable stroke range or setting to the middle stroke

LCX - 25 - S02

Bore size
(A at page 12)

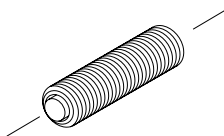

A adjustable stroke range	
S01	Single 10 mm (standard)
S02	Single 20 mm

How to order discrete metal type stopper

- Use for changing the adjustable stroke range or setting to the middle stroke

LCX - 25 - M02

Bore size
(A at page 12)

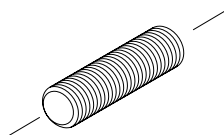

A Adjustable stroke range	
M01	Single 10 mm (standard)
M02	Single 20 mm

How to order the discrete shock absorber stopper

- A set of a shock absorber and a stopper cap
- Used when changing from a rubber cushion type or metal type stopper to a shock absorber type stopper

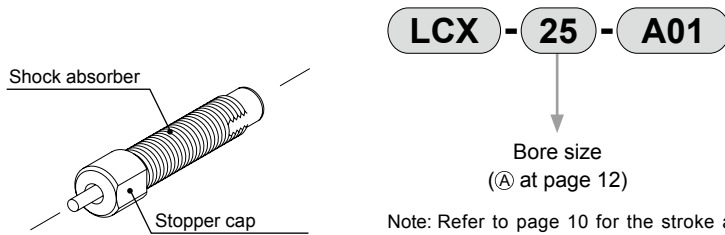

Note: Refer to page 10 for the stroke adjustment range of the shock absorber type stopper.

Applicable shock absorber model No.

Model	Shock absorber model no.
LCX-25	NCK-00-1.2
LCX-32	NCK-00-1.2

How to order stopper block discrete part

- Used when changing from the standard to a rubber cushion type stopper, a metal type stopper, or a shock absorber stopper

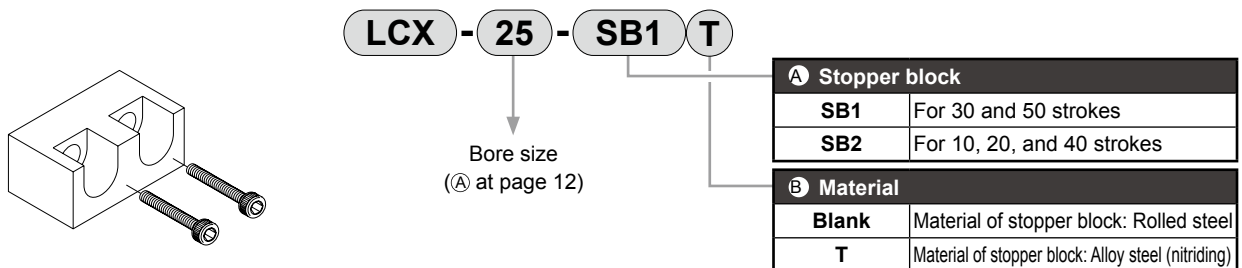

How to order the positioning bolt

- Hexagon socket head cap bolt with positioning mechanism
- Cross units and 2-stage units can be assembled without position adjustment.

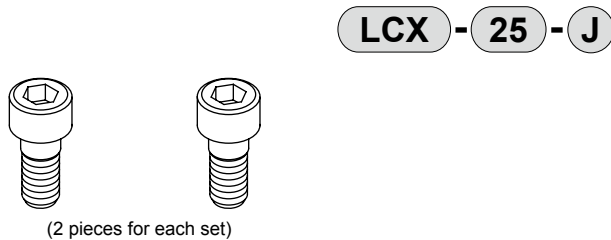

How to order cylinder

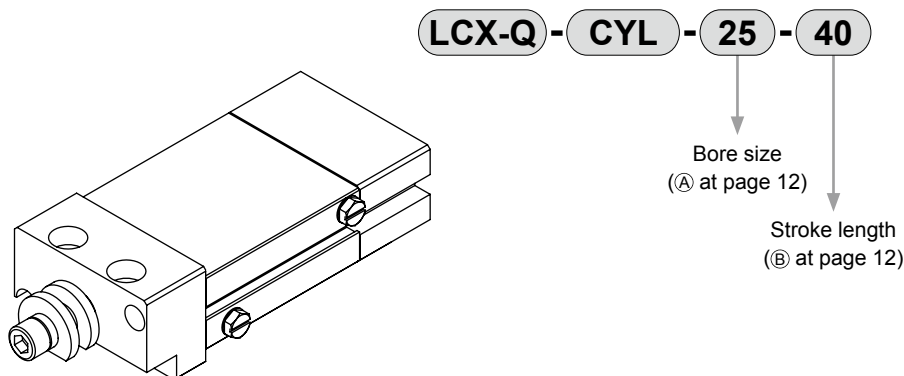

Internal structure and parts list

● LCX

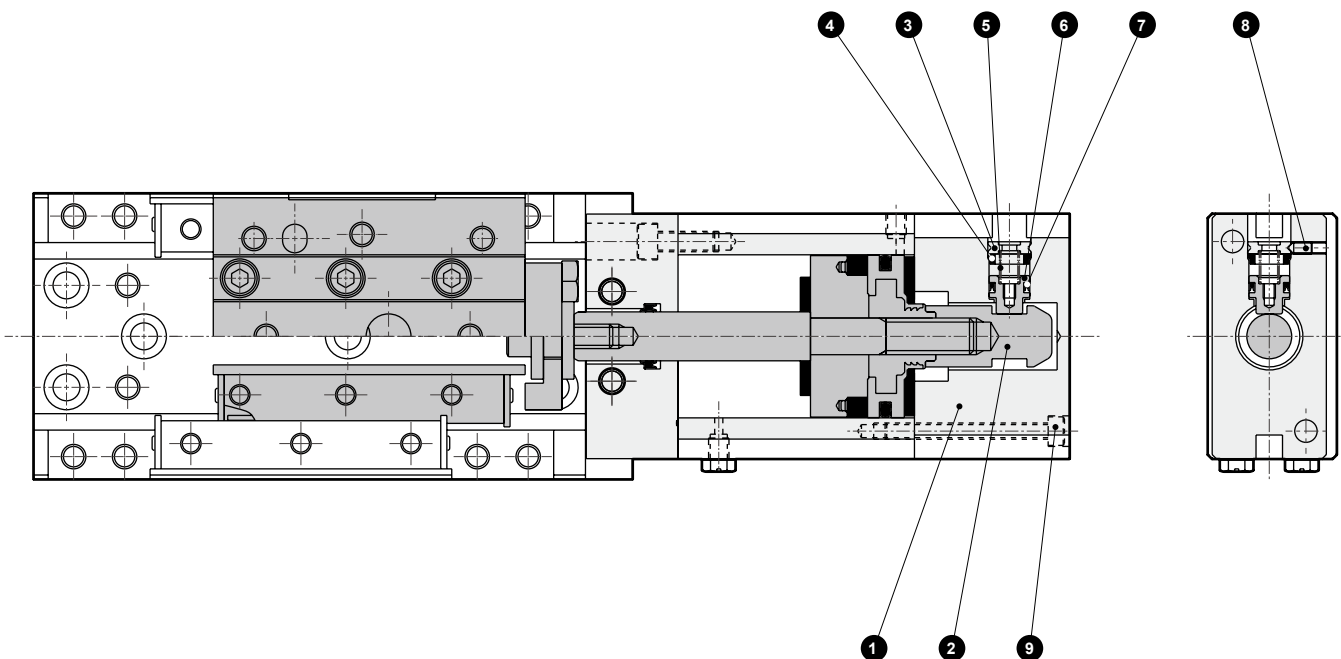

Parts list

No.	Parts name	Material	Remarks	No.	Parts name	Material	Remarks
1	Head cover	Aluminum alloy	Alumite	6	Stopper piston	Carbon steel	Nitriding
2	Sleeve	Carbon steel	Nitriding	7	Stopper packing seal	Nitrile rubber	
3	Stopper guard	Stainless steel		8	Hexagon socket head set screw	Alloy steel	Blackening
4	Cushion rubber	Urethane rubber		9	Hexagon socket head cap bolt	Alloy steel	Zinc chromate
5	Coil spring	Steel					

Repair parts list

Bore size (mm)	Kit no.	Repair parts number	
		Position locking unit repair parts	Basic unit repair parts
ø25	LCZ-Q-25K		17 18
ø32	LCX-Q-32K	4 7	20 23

Note: For basic repair parts No., refer to the parts list of the double acting and single rod type on page 7.

Dimensions

- Double acting position locking type LCX-Q-25, 32

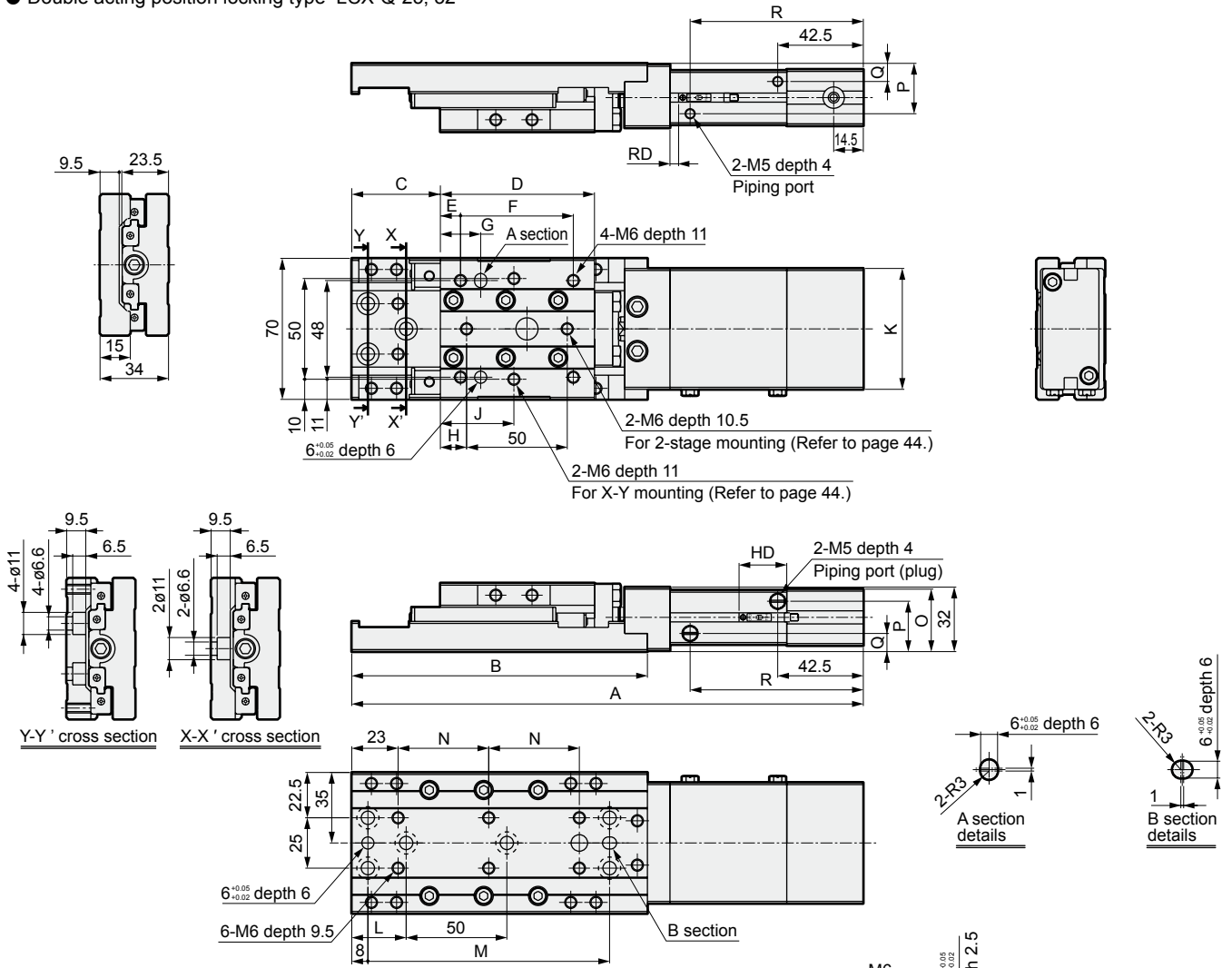

- With dowel hole LCX-Q-25, 32-E

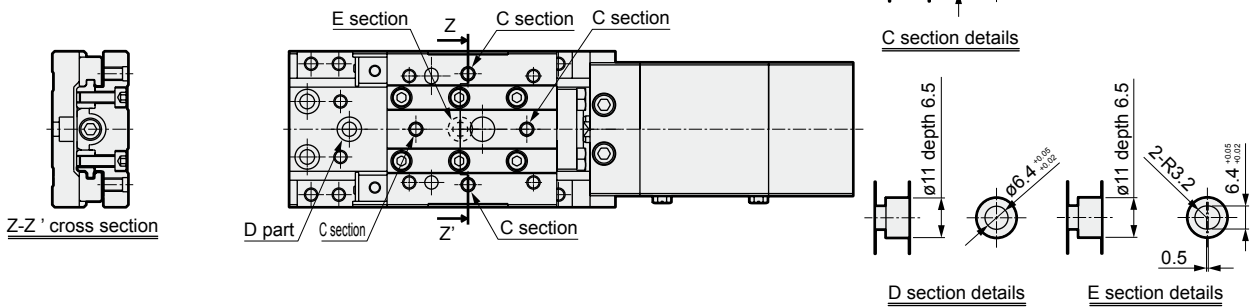

Bore size	Stroke length	A	B	C	D	E	F	G	H	J	K	L	M	N	O	P	Q	R	RD			HD		
																			T0*	T2*	T2W*	T0*	T2*	T2W*
																			T5*	T3*	T3W*	T5*	T3*	T3W*
ø25	10	234		34														66	5	6.5	23.5	21.5		
	20	244	147	39	76.5	10	56	20	13	36.5		27	120	45				76						
	30	254		44							50				29.5	24.5	9.5	86						
	40	284		49	86.5	15	64	30	23	46.5		41	140	55				96						
	50	294	167	54														106						
ø32	10	234		34														66	5	6.5	23.5	21.5		
	20	244	147	39	76.5	10	56	20	13	36.5		27	120	45				76						
	30	254		44							60				31	25	9	86						
	40	284		49	86.5	15	64	30	23	46.5		41	140	55				96						
	50	294	167	54														106						

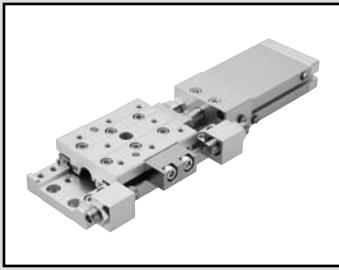

Linear slide cylinder double acting / single rod type clean room specifications

LCX-P7* Series

● Bore size: $\varnothing 25/\varnothing 32$

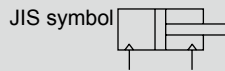

Specifications

Descriptions		LCX-P7 *	
Bore size	mm	$\varnothing 25$	$\varnothing 32$
Actuation		Double acting	
Working fluid		Compressed air	
Max. working pressure	MPa	0.7	
Min. working pressure	MPa	0.15	
Withstanding pressure	Mpa	1.05	
Ambient temperature	°C	-10 to 60 (not freezing) (Note 1)	
Port size		M5	
Relief port size		M5	
Stroke tolerance	mm	+2.0 0 (Note 2)	
Working piston speed	mm/s	20 to 500	
Cushion		Rubber cushioned	
Lubrication		Not available	
Allowable energy absorption	J	Refer to table 3 on Page 46.	

Note 1: Please consult us if you use the instrument in an environment of constantly low (5°C or less) or high (40°C or over) temperature.

Note 2: When not using a stopper, a slight gap may exist between the end plate and floating bushing.

Note 3: Use the metal stopper between 20 and 200 mm/s.

Stroke length

Bore size (mm)	Standard stroke length (mm)
$\varnothing 25$	10, 20, 30, 40, 50
$\varnothing 32$	10, 20, 30, 40, 50

Note: Stroke length other than above is not available.

Switch specifications

* The T0/T5 switch can be used with 220 VAC.

Contact CKD for working conditions.

● 1 color/2 color indicator

Descriptions	Reed 2 wire				Proximity 2 wire		Proximity 3 wire	
	T0H/T0V		T5H/T5V		T2H/T2V	T2WH/T2WV	T3H/T3V	T3WH/T3WV
Applications	Programmable controller, relay		Programmable controller, relay, IC circuit (w/o light), serial connection		Programmable controller		Programmable controller, relay	
Output method	-		-		-		NPN output	
Power voltage	-		-		-		10 to 28 VDC	
Load voltage	12/24 VDC	110 VAC	5/12/24 VDC	110 VAC	10 to 30 VDC	24 VDC \pm 10%	30 VDC or less	
Load current	5 to 50 mA	7 to 20 mA	50 mA or less	20 mA or less	5 to 20 mA		100 mA or less	50 mA or less
Light	LED (ON lighting)		Without indicator light		LED (ON lighting)	Red/green-LED (ON lighting)	LED (ON lighting)	Red/green LED (ON lighting)
Leakage current	0 mA				1 mA or less		10 μ A or less	

Cylinder weight

● Clean specification

(Unit: g)

Bore size (mm)	Basic type stroke length type (mm)				
	10	20	30	40	50
$\varnothing 25$	1,010	1,040	1,060	1,180	1,200
$\varnothing 32$	1,060	1,090	1,110	1,240	1,260

● Increased variations and options (stopper section)

(Unit: g)

Bore size (mm)	Option stopper symbol			
	S1 to S4	M1 to M4	S5/S6	M5/M6
$\varnothing 25$	170		240	
$\varnothing 32$	170		240	

How to order

Without switch

LCX - 25 - 40 ————— S5 E P72

With switch

LCX - 25 - 40 - T2H* - R - S1T E P72

Model no.

A Bore size

B Stroke length

F Option

G Clean specification

C Switch model no.

D Switch quantity

E Stopper

⚠ Note on model no. selection

Note 1: Use a discrete rubber cushion type stopper or a metal type stopper on page 19 when changing the adjustable stroke range.

Note 2: Selectable only when using a stopper type.

Note 3: When using a metal type stopper, stopper block material copper alloy (symbol: T) is recommended.

Note 4: When a rubber cushion type stopper and a metal type stopper is used in combination, they are provided for each custom order.

Note 5: Use the metal stopper between 20 and 200 mm/s.

Note 6: Refer to page 20 for cylinder model numbers.

<Example of model number>

LCX-25-40-T2H-R-S1TEP72

Model: Linear slide cylinder double acting/single rod type
(clean room specifications) LCX-P7*

A Bore size : $\phi 25$

B Stroke : 40 mm

C Switch model no. : Proximity, 2-wire type
Axial lead wire

D Switch quantity : With one pc. on rod end

E Stopper : Rubber cushion type stopper
Stopper position (1)
Material, alloy steel (nitriding)

F Option : Dowel hole

G Clean room specifications : exhaust treatment

● Stopper position

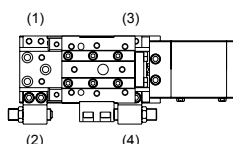

Symbol	Descriptions			
A Bore size				
25	$\phi 25$			
32	$\phi 32$			
B Stroke length (mm)				
10	10			
20	20			
30	30			
40	40			
50	50			
C Switch model no.				
Axial lead wire	Radial lead wire	Contact	Indicator	Lead wire
T0H*	T0V*	Reed	One color indicator type	2-wire
T5H*	T5V*		Without indicator light	
T2H*	T2V*	Proximity	One color indicator type	2-wire
T3H*	T3V*		Two color indicator type	3-wire
T2WH*	T2WV*		Two color indicator type	2-wire
T3WH*	T3WV*		Two color indicator type	3-wire
* Lead wire length				
Blank	1 m (standard)			
3	3 m (option)			
5	5 m (option)			
D Switch quantity				
R	One on rod end			
H	One on head end			
D	Two			
E Stopper				
Blank	without stopper			
S: Rubber cushion type stopper Note 1, Note 4				
S1*	Stopper position (1) (can be changed to (4))			Stopper installation position
S2*	Stopper position (2) (can be changed to (3))			
S3*	Stopper position (3) (can be changed to (2))			
S4*	Stopper position (4) (can be changed to (1))			
S5*	Stopper position (1), (3)			
S6*	Stopper position (2), (4)			
M: Metal type stopper Note 1, Note 3, Note 4, Note 5				
M1*	Stopper position (1) (can be changed to (4))			Stopper installation position
M2*	Stopper position (2) (can be changed to (3))			
M3*	Stopper position (3) (can be changed to (2))			
M4*	Stopper position (4) (can be changed to (1))			
M5*	Stopper position (1), (3)			
M6*	Stopper position (2), (4)			
* Section				
Blank	Material of stopper block: Rolled steel			
T	Material of stopper block: Alloy steel (nitriding) Note 2			
F Option				
Blank	No options			
E	With dowel hole			
G Clean specification				
Structure				
P72	Exhaust treatment			
P73	Vacuum treatment			

How to order switch

SW - T2H3

Switch model no.
(© at page 18)

How to order stopper set

- A set of a stopper section and a rubber cushion stopper or a metal type stopper
- Used when changing from the standard to a rubber cushion type stopper or a metal type stopper

LCX - 25 - S 2 - S02

Bore size
(A at page 18)

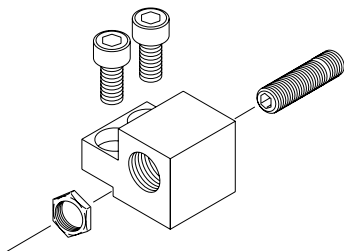

A Stopper type	
S	Rubber cushion type stopper
M	Metal type stopper
B Stopper installation position	
1	For stopper position (1) or (4)
2	For stopper position (2) or (3)
C Adjustable stroke length Note 1	
Blank	Adjustable stroke range 10 mm
S02	Adjustable stroke range 20 mm

How to order rubber cushion type stopper

- Hexagon socket head set screw with urethane rubber
- Use for changing the adjustable stroke range or setting to the middle stroke

LCX - 25 - S02

Bore size
(A at page 18)

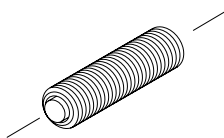

A Adjustable stroke range	
S01	Single 10 mm (standard)
S02	Single 20 mm

How to order discrete metal type stopper

- Use for changing the adjustable stroke range or setting to the middle stroke

LCX - 25 - M02

Bore size
(A at page 18)

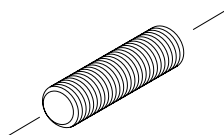

A Adjustable stroke range	
M01	Single 10 mm (standard)
M02	Single 20 mm

How to order stopper block discrete part

- Used when changing from the standard to a rubber cushion type stopper or a metal type stopper

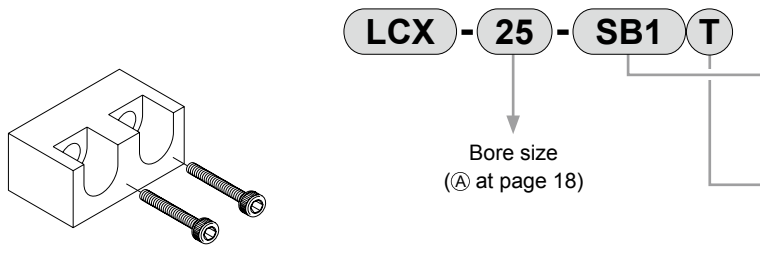

LCX - 25 - SB1 - T

Bore size
(A at page 18)

A Stopper block	
SB1	For 30 and 50 strokes
SB2	For 10, 20, and 40 strokes

B Material	
Blank	Material of stopper block: Rolled steel
T	Material of stopper block: Alloy steel (nitriding)

How to order the positioning bolt

- Hexagon socket head cap bolt with positioning mechanism
- Cross units and 2-stage units can be assembled without position adjustment.

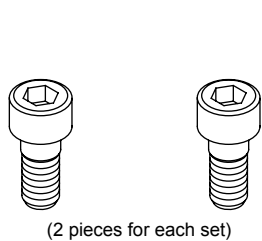

LCX - 25 - J

(2 pieces for each set)

How to order cylinder

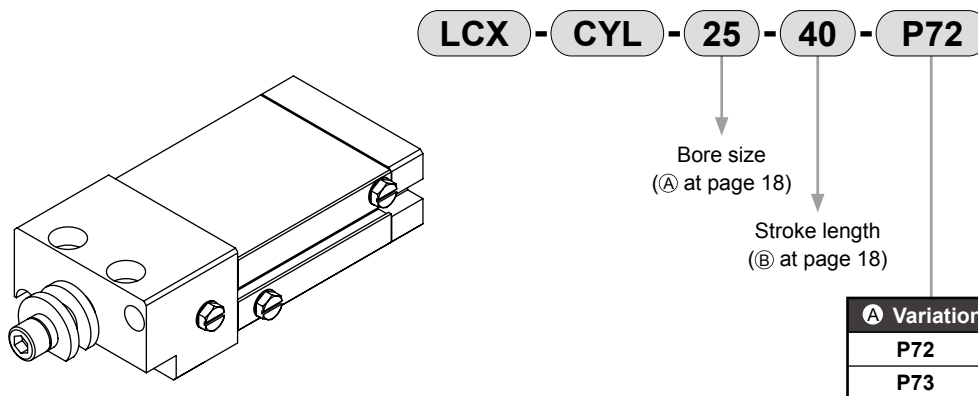

LCX - CYL - 25 - 40 - P72

Bore size
(A at page 18)

Stroke length
(B at page 18)

A Variation	
P72	Clean room specifications (exhaust treatment)
P73	Clean room specifications (vacuum treatment)

LCX-P7* Series

Dimensions

● Double acting / clean room specifications LCX-25, 32-P7*

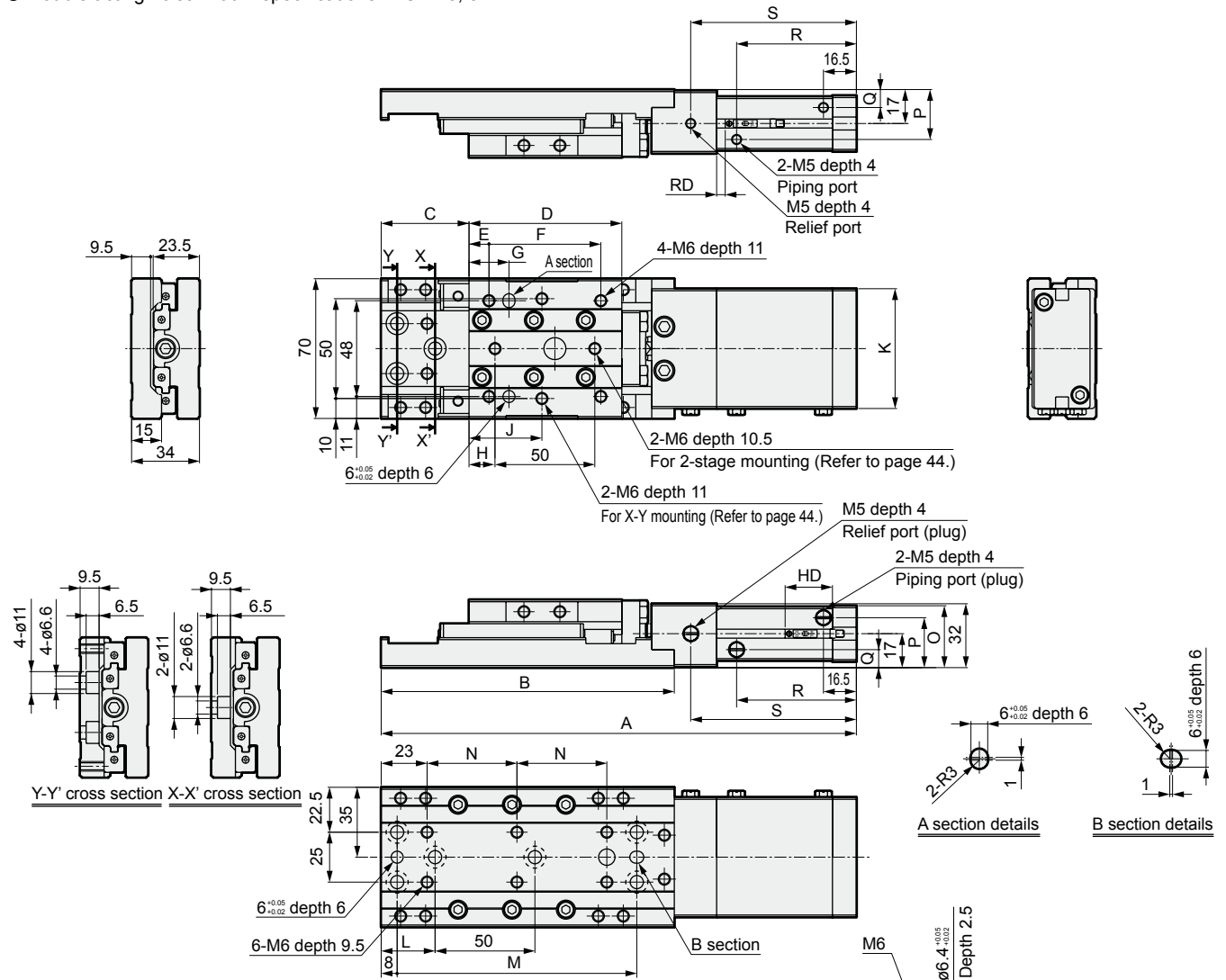

● With dowel hole LCX-25, 32-EP7*

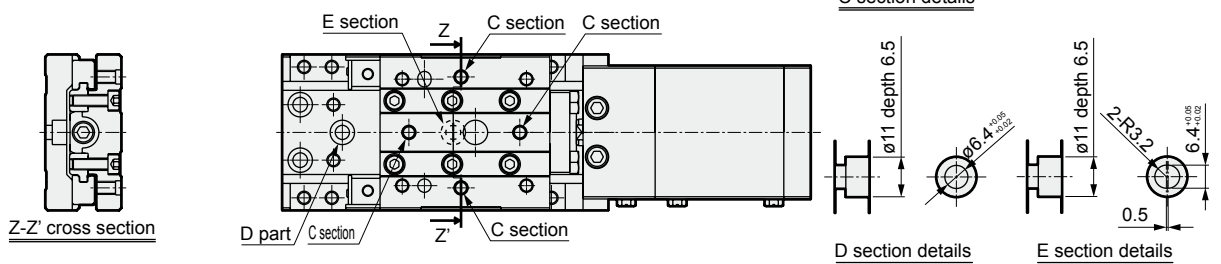

Bore size	Stroke length	A	B	C	D	E	F	G	H	J	K	L	M	N	O	P	Q	R	S	RD			HD		
																				T0*	T2*	T2W*	T0*	T2*	T2W*
																				T5*	T3*	T3W*	T5*	T3*	T3W*
ø25	10	218		34														40	63						
	20	228	147	39	76.5	10	56	20	13	36.5		27	120	45				50	73						
	30	238		44														60	83						
	40	268		49														70	93						
	50	278	167	54	86.5	15	64	30	23	46.5	50	41	140	55				80	103						
ø32	10	218		34														40	63						
	20	228	147	39	76.5	10	56	20	13	36.5		27	120	45				50	73						
	30	238		44														60	83						
	40	268		49														70	93						
	50	278	167	54	86.5	15	64	30	23	46.5	60	41	140	55				80	103						

MEMO

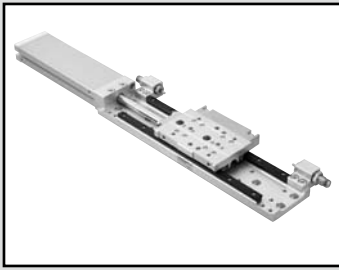

Linear slide cylinder double acting / single rod type /long stroke

LCX-*L Series

● Bore size: $\varnothing 25/\varnothing 32$



Specifications

Descriptions		LCX	
		$\varnothing 25$	$\varnothing 32$
Bore size	mm		
Actuation		Double acting	
Working fluid		Compressed air	
Max. working pressure	MPa	0.7	
Min. working pressure	MPa	0.15	
Withstanding pressure	Mpa	1.05	
Ambient temperature	°C	-10 to 60 (not freezing) (Note 1)	
Port size		M5	
Stroke tolerance	mm	+2.0 0 (Note 2)	
Working piston speed	mm/s	20 to 500 (Note 3)	
Cushion		Rubber cushioned	
Lubrication		Not available	
Allowable energy absorption	J	Refer to table 3 on Page 46.	

Note 1: Please consult us if you use the instrument in an environment of constantly low (5°C or less) or high (40°C or over) temperature.

Note 2: When not using a stopper, a slight gap may exist between the end plate and floating bushing.

Note 3: Use the metal stopper between 20 and 200 mm/s.

Stroke length

Bore size (mm)	Standard stroke length (mm)
$\varnothing 25$	75, 100, 125, 150
$\varnothing 32$	75, 100, 125, 150

Note: Stroke length other than above is not available.

Switch specifications

* The T0/T5 switch can be used with 220 VAC.
Contact CKD for working conditions.

- 1/2 color indicator

Descriptions	Reed 2 wire				Proximity 2 wire		Proximity 3 wire	
	T0H/T0V		T5H/T5V		T2H/T2V	T2WH/T2WV	T3H/T3V	T3WH/T3WV
Applications	Programmable controller, relay		Programmable controller, relay, IC circuit (w/o light), serial connection		Programmable controller		Programmable controller, relay	
Output method	-		-		-		NPN output	
Power voltage	-		-		-		10 to 28 VDC	
Load voltage	12/24 VDC	110 VAC	5/12/24 VDC	110 VAC	10 to 30 VDC	24 VDC ± 10%	30 VDC or less	
load current	5 to 50 mA	7 to 20 mA	50 mA or less	20 mA or less	5 to 20 mA		100 mA or less	50 mA or less
Light	LED (ON lighting)		Without indicator light		LED (ON lighting)	Red/green LED (ON lighting)	LED (ON lighting)	Red/green LED (ON lighting)
Leakage current	0 mA				1 mA or less		10 µA or less	

Cylinder weight

- Basic type

(Unit: g)

Bore size (mm)	Basic type stroke length (mm)			
	75	100	125	150
ø25	1,500	1,640	1,790	1,930
ø32	1,600	1,750	1,900	2,050

- Options newly added

(Unit: g)

Bore size (mm)	Option stopper symbol					
	S1 to S4	M1 to M4	A1 to A4	S5/S6	M5/M6	A5/A6
ø25	320			400		
ø32	320			400		

Specification for LiB production

LCX - *L ... -

P4*

- Design applicable for LiB manufacturing process

* Consult with CKD for details.

How to order

Without switch

LCX - 25 L - 100 ————— S5

With switch

LCX - 25 L - 100 - T2H* - R - A1T

Model no.

Ⓐ Bore size

Ⓑ Stroke length

Ⓒ Switch model no.

Ⓓ Switch quantity

Ⓔ Stopper

⚠ Note on model no. selection

Note 1: Use a discrete rubber cushion type stopper or a metal type stopper on page 27 when changing the adjustable stroke range.

Note 2: When using a shock absorber, refer to the stopper dimensions table on page 32 for the adjustable stroke range.

Note 3: When using a metal type stopper, stopper block material copper alloy (symbol: T) is recommended.

Note 4: When a rubber cushion type stopper or a metal type stopper is used in combination with a shock absorber type stopper, they are provided for each custom order.

Note 5: Use the metal stopper between 20 and 200 mm/s.

Note 6: Selectable only when using a stopper type.

Note 7: The dowel hole option (symbol: E) is provided as standard for long stroke.

Note 8: Refer to page 28 for cylinder model numbers.

<Example of model number>

LCX-25L-100-T2H-R-A1T

Model: Linear slide cylinder double acting / single rod type LCX

- Ⓐ Bore size : $\varnothing 25$
- Ⓑ Stroke : 100 mm
- Ⓒ Switch model no.: Proximity, 2-wire type
Axial lead wire
- Ⓓ Switch quantity : With one pc. on rod end
- Ⓔ Other options : Shock absorber type stopper
Stopper position (1)
Material, alloy steel (nitriding)

● Stopper position

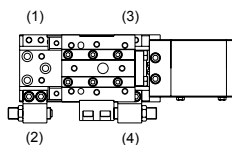

Symbol	Descriptions			
Ⓐ Bore size				
25	$\varnothing 25$			
32	$\varnothing 32$			
Ⓑ Stroke length (mm)				
75	75			
100	100			
125	125			
150	150			
Ⓒ Switch model no.				
Axial lead wire Type	Lead wire L shape Type	Contact	Indicator	Lead wire
T0H*	T0V*	Reed	One color indicator type	2-wire
T5H*	T5V*		Without indicator light	
T2H*	T2V*	Proximity	One color indicator type	2-wire
T3H*	T3V*		3-wire	
T2WH*	T2WV*		Two color indicator type	2-wire
T3WH*	T3WV*		3-wire	
*Lead wire length				
Blank	1 m (standard)			
3	3 m (option)			
5	5 m (option)			
Ⓓ Switch quantity				
R	One on rod end			
H	One on head end			
D	Two			
Ⓔ Stopper				
Blank	Without stopper			
S: Rubber cushion type stopper Note 1, Note 4				
S1*	Stopper position (1) (can be changed to (4))			Stopper installation position
S2*	Stopper position (2) (can be changed to (3))			
S3*	Stopper position (3) (can be changed to (2))			
S4*	Stopper position (4) (can be changed to (1))			
S5*	Stopper position (1), (3)			
S6*	Stopper position (2), (4)			
M: Metal type stopper Note 1, Note 3, Note 4, Note 5				
M1*	Stopper position (1) (can be changed to (4))			Stopper installation position
M2*	Stopper position (2) (can be changed to (3))			
M3*	Stopper position (3) (can be changed to (2))			
M4*	Stopper position (4) (can be changed to (1))			
M5*	Stopper position (1), (3)			
M6*	Stopper position (2), (4)			
A: Shock absorber type stopper Note 2, Note 4, Note 7				
A1*	Stopper position (1) (can be changed to (4))			Stopper installation position
A2*	Stopper position (2) (can be changed to (3))			
A3*	Stopper position (3) (can be changed to (2))			
A4*	Stopper position (4) (can be changed to (1))			
A5*	Stopper position (1), (3)			
A6*	Stopper position (2), (4)			
* Section				
Blank	Material of stopper block: Rolled steel			
T	Material of stopper block: Alloy steel (nitriding) Note 6			

How to order switch

SW - T2H3

Switch model no.
(© at page 25)

How to order stopper set

- A set of a stopper section and a rubber cushion stopper, a metal type stopper, or a shock absorber stoppers
- Used when changing from the standard to a rubber cushion stopper, a metal type stopper, or a shock absorber stopper

LCX - 25 - S 2 - S02

Bore size
(A at page 25)

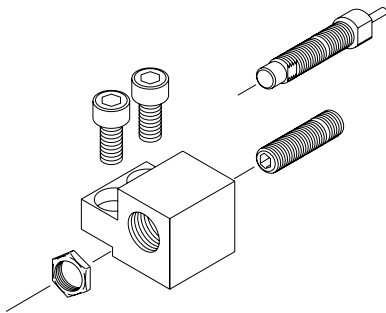

A Stopper type	
S	Rubber cushion type stopper
M	Metal type stopper
A	Shock absorber type stopper
B Stopper installation position	
1	For stopper position (1) or (4)
2	For stopper position (2) or (3)
C Adjustable stroke length Note 1	
Blank	Adjustable stroke range 10 mm
S02	Adjustable stroke range 20 mm

Note 1: Not selectable for shock absorber type stopper "A".

How to order rubber cushion type stopper

- Hexagon socket head set screw with urethane rubber
- Use for changing the adjustable stroke range or setting to the middle stroke

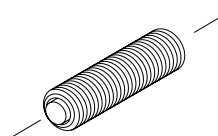

LCX - 25 - S02

Bore size
(A at page 25)

A Adjustable stroke range	
S01	Single 10 mm (standard)
S02	Single 20 mm

How to order discrete metal type stopper

- Use for changing the adjustable stroke range or setting to the middle stroke

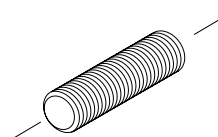

LCX - 25 - M02

Bore size
(A at page 25)

A Adjustable stroke range	
M01	Single 10 mm (standard)
M02	Single 20 mm

How to order the discrete shock absorber stopper

- A set of a shock absorber and a stopper cap
- Used when changing from a rubber cushion type or metal type stopper to a shock absorber type stopper

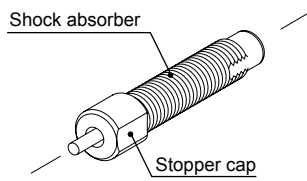

LCX - 25 - A01

Bore size
(A at page 25)

Note: Refer to page 32 for the stroke adjustment range of the shock absorber type stopper.

Applicable shock absorber model No.

Model	Shock absorber model no.
LCX-25	NCK-00-1.2
LCX-32	NCK-00-1.2

How to order stopper block discrete part

- Used when changing from the standard to a rubber cushion type stopper, a metal type stopper, or a shock absorber stopper

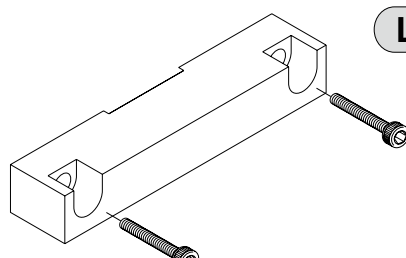

LCX - 25 L - SB3 T

Bore size
(A at page 25)

A Material	
Blank	Material of stopper block: Rolled steel
T	Material of stopper block: Alloy steel (nitriding)

How to order the positioning bolt

- Hexagon socket head cap bolt with positioning mechanism
- Cross units and 2-stage units can be assembled without position adjustment.

LCX - 25 - J

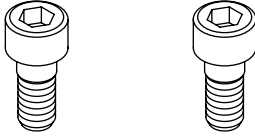

(2 pieces for each set)

How to order cylinder

LCX - CYL - 25 L - 100

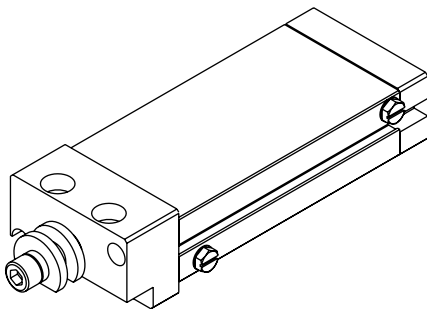

Bore size
(A at page 25)

Stroke length
(B at page 25)

Internal structure and parts list

● LCX

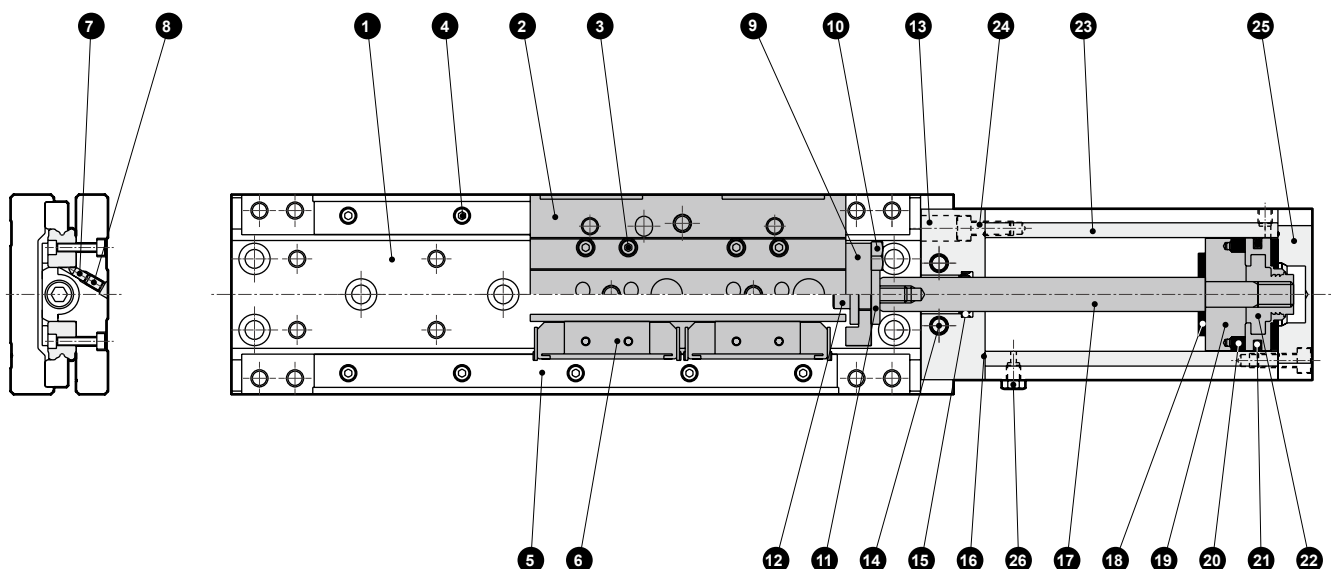

Parts list

No.	Parts name	Material	Remarks	No.	Parts name	Material	Remarks
1	Base	Aluminum alloy	Alumite	14	Hexagon socket head cap bolt	Alloy steel	Zinc chromate
2	Table	Aluminum alloy	Alumite	15	Nod packing seal	Nitrile rubber	
3	Hexagon socket head cap bolt	Alloy steel	Zinc chromate	16	Gasket	Nitrile rubber	
4	Hexagon socket head cap bolt	Alloy steel	Zinc chromate	17	Piston rod	Alloy steel	Industrial chrome plated
5	Guide rail	Alloy steel	Black chrome film	18	Cushion rubber	Urethane rubber	
6	End block	Alloy steel + resin	Black chrome film (alloy steel part)	19	Spacer	Aluminum alloy	
7	Adjustment pin	Stainless steel		20	Magnet	Plastic	
8	Hexagon socket head set screw	Alloy steel	Zinc chromate	21	Piston packing seal	Nitrile rubber	
9	Plate	Aluminum alloy	Alumite	22	Piston	Aluminum alloy + polyacetal	
10	Hexagon head bolt	Stainless steel		23	Cylinder body	Aluminum alloy	Hard alumite
11	Floating bush	Stainless steel		24	Hexagon socket head cap bolt	Stainless steel	
12	Hexagon socket head cap bolt	Alloy steel	Zinc chromate	25	Head cover	Aluminum alloy	Alumite
13	Rod cover	Aluminum alloy	Alumite	26	Plug	Brass	Nickeling

Repair parts list

Bore size (mm)	Kit no.	Basic unit repair parts
ø25	LCX-25K	15 16
ø32	LCX-32K	18 21

Internal structure and parts list

Configuration with stopper

● Rubber cushion type stopper, metal type stopper

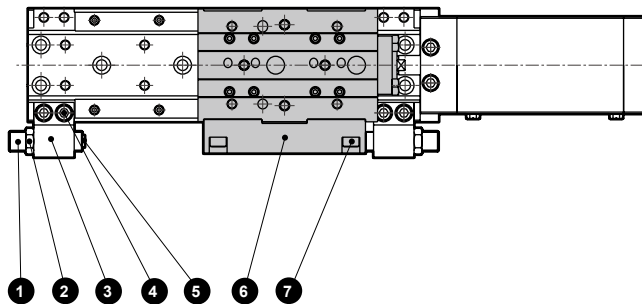

● Shock absorber type stopper

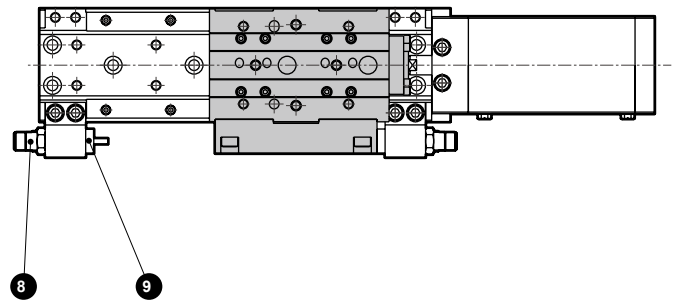

Parts list

No.	Parts name	Material	Remarks	No.	Parts name	Material	Remarks
1	Stopper bolt	Alloy steel	Nickeling	6	Stopper block (stopper block symbol: blank)	Steel	Nickeling
2	Hexagon nut	Alloy steel	Zinc chromate		Stopper block (stopper block symbol: T)	Alloy steel	Nitriding
3	Stopper	Aluminum alloy	Alumite	7	Hexagon socket head cap bolt	Alloy steel	Zinc chromate
4	Hexagon socket head cap bolt	Alloy steel	Zinc chromate	8	Shock absorber		
5	Cushion rubber	Urethane rubber	Only rubber cushion type stopper	9	Stop cap	Stainless steel	

Dimensions

● Double acting / single rod / long stroke type LCX-^{*}L

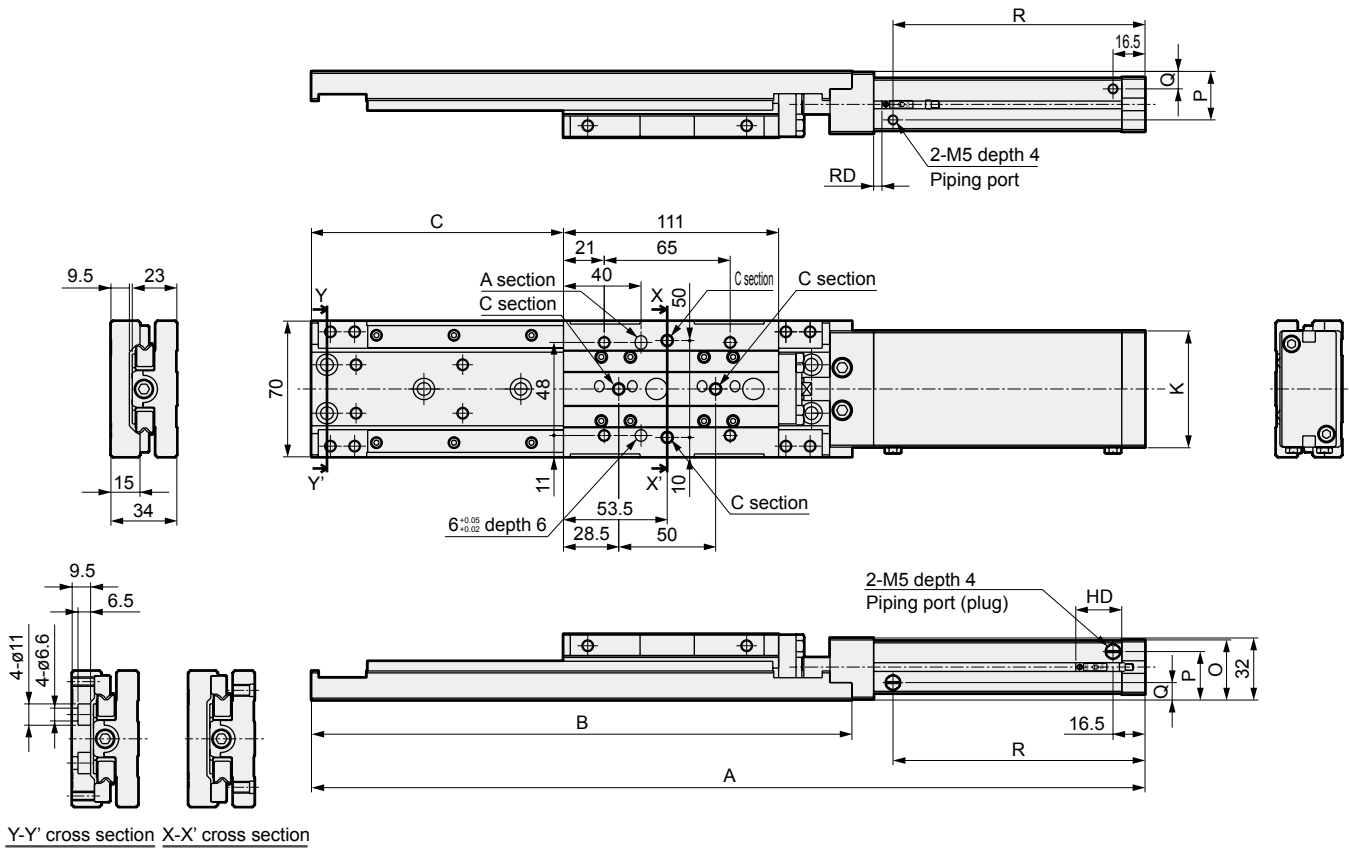

Y-Y' cross section X-X' cross section

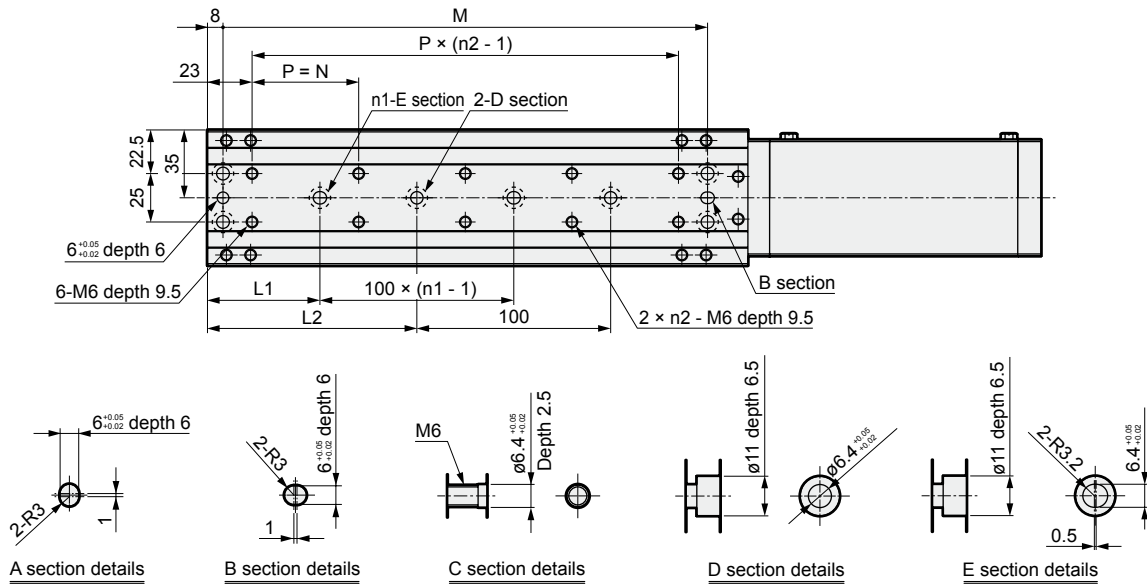

A section details

B section details

C section details

D section details

E section details

Bore size	Stroke length	A	B	C	K	L1	L2	n1	n2	M	N	O	P	Q	R	RD			HD		
																T0*	T2*	T2W*	T0*	T2*	T2W*
																T5*	T3*	T3W*	T5*	T3*	T3W*
ø25	75	380	254	105	50	45.5	95.5	2	5	225	49	29.5	24.5	9.5	105	5	6.5	23.5	21.5		
	100	430	279	130		58	108	2	5	250	55									130	
	125	480	304	155		45.5	95.5	3	6	275	49									155	
	150	530	329	180		58	108	3	6	300	54									180	
ø32	75	380	254	105	60	45.5	95.5	2	5	225	49	31	25	9	105	5	6.5	23.5	21.5		
	100	430	279	130		58	108	2	5	250	55									130	
	125	480	304	155		45.5	95.5	3	6	275	49									155	
	150	530	329	180		58	108	3	6	300	54									180	

Dimensions: Option

- Rubber cushion type stopper (S1 to S6)

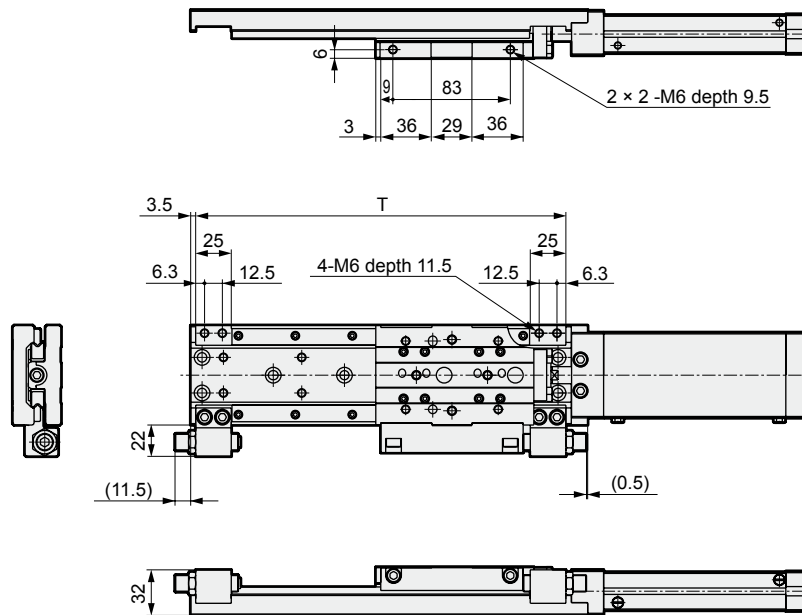

- Metal type stopper (M1 to M6)

- Shock absorber type stopper (A1 to A6)

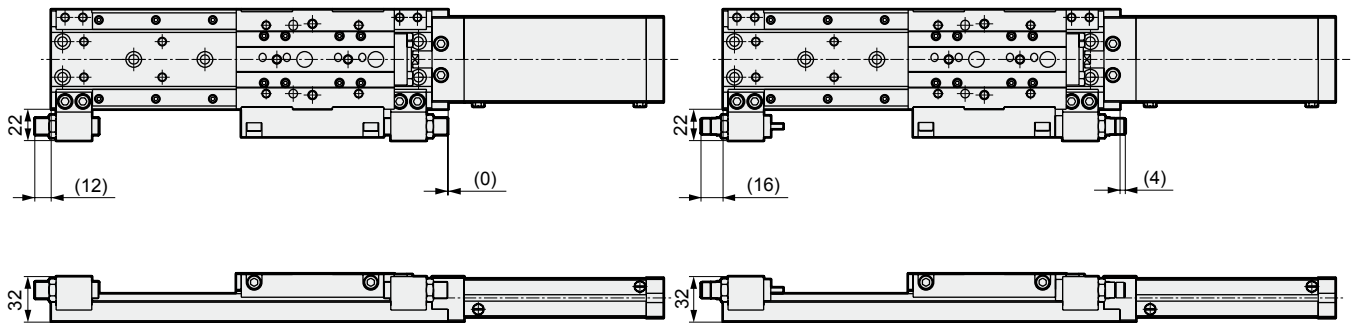

Note: If the adjustable stroke range is changed by the rubber cushion type stopper (S1 to S6) or metal type stopper (M1 to M6), the value within () will be changed accordingly.

Bore size	Stroke length	T	Adjustable stroke range (single)		
			Rubber cushion type stopper	Metal type stopper	Shock absorber type stopper
ø25	75	235	10	10	7
	100	260			
	125	285			
	150	310			
ø32	75	235	10	10	7
	100	260			
	125	285			
	150	310			

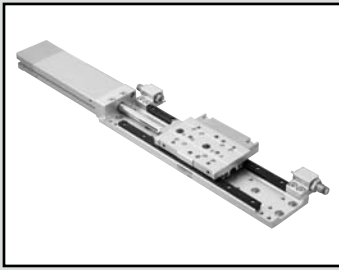

Linear slide cylinder double acting / single rod type / position locking type long stroke

LCX-Q-*L Series

- Bore size: $\phi 25/\phi 32$

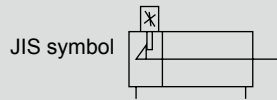

Specifications

Descriptions		LCX-Q-*L	
Bore size	mm	$\phi 25$	$\phi 32$
Actuation		Double acting	
Working fluid		Compressed air	
Max. working pressure	MPa	0.7	
Min. working pressure	MPa	0.15	
Withstanding pressure	Mpa	1.05	
Ambient temperature	°C	-10 to 60 (not freezing) (Note 1)	
Port size		M5	
Stroke tolerance	mm	+2.0 0 (Note 2)	
Working piston speed	mm/s	20 to 500 (Note 3)	
Cushion		Rubber cushioned	
Holding force	N	130	230
Position locking mechanism		Head end	
Lubrication		Not available	
Allowable energy absorption	J	Refer to table 3 on Page 46.	

Note 1: Please consult us if you use the instrument in an environment of constantly low (5°C or less) or high (40°C or over) temperature.

Note 2: When not using a stopper, a slight gap may exist between the end plate and floating bushing.

Note 3: Use the metal stopper between 20 and 200 mm/s.

Stroke length

Bore size (mm)	Standard stroke length (mm)
$\phi 25$	75, 100, 125, 150
$\phi 32$	75, 100, 125, 150

Note: Stroke length other than above is not available.

Switch specifications

* The T0/T5 switch can be used with 220 VAC.
Contact CKD for working conditions.

- 1/2 color indicator

Descriptions	Reed 2 wire				Proximity 2 wire		Proximity 3 wire	
	T0H/T0V		T5H/T5V		T2H/T2V	T2WH/T2WV	T3H/T3V	T3WH/T3WV
Applications	Programmable controller, relay		Programmable controller, relay, IC circuit (w/o light), serial connection		Programmable controller		Programmable controller	
Output method	-		-		-		NPN output	
Power voltage	-		-		-		10 to 28 VDC	
Load voltage	12/24 VDC	110 VAC	5/12/24 VDC	110 VAC	10 to 30 VDC	24 VDC \pm 10%	30 VDC or less	
Load current	5 to 50 mA	7 to 20 mA	50 mA or less	20 mA or less	5 to 20 mA		100 mA or less	50 mA or less
Light	LED (ON lighting)		Without indicator light		LED (ON lighting)	Red/green LED (ON lighting)	LED (ON lighting)	Red/green LED (ON lighting)
Leakage current	0 mA				1 mA or less		10 μ A or less	

Cylinder weight

- Position locking type

(Unit: g)

Bore size (mm)	Basic type stroke length type (mm)			
	75	100	125	150
$\phi 25$	1,580	1,720	1,870	2,010
$\phi 32$	1,730	1,880	2,030	2,180

- Additional weight for options (stopper)

(Unit: g)

Bore size (mm)	Option stopper symbol		
	S1/S2	M1.M2	A1/A2
$\phi 25$	320		
$\phi 32$			

How to order

Without switch

LCX-Q-25L-100-S5

With switch

LCX-Q-25L-100-T2H*-R-S1T

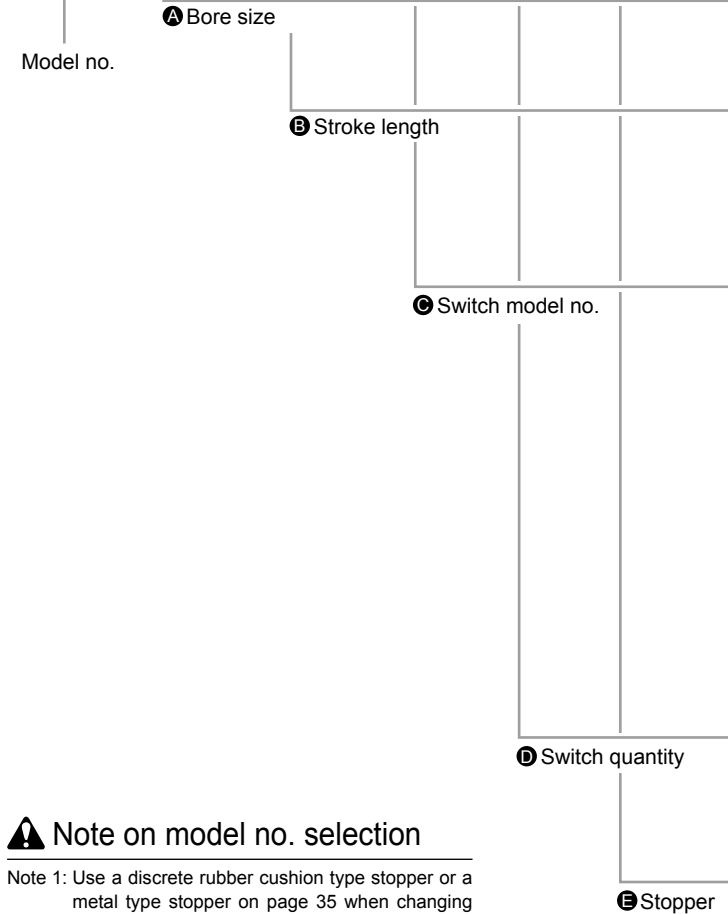

⚠ Note on model no. selection

- Note 1: Use a discrete rubber cushion type stopper or a metal type stopper on page 35 when changing the adjustable stroke range.
- Note 2: When using a shock absorber, refer to the stopper dimensions table on page 32 for the adjustable stroke range.
- Note 3: When using a metal type stopper, stopper block material copper alloy (symbol: T) is recommended.
- Note 4: When a rubber cushion type stopper or a metal type stopper is used in combination with a shock absorber type stopper, they are provided for each custom order.
- Note 5: Use it in 20 to 200 mm/s when used with a metal stopper.
- Note 6: Selectable only when using a stopper type.
- Note 7: The locking mechanism works at the stroke end. Do not mount it stopper positions (3) and (4).
- Note 8: The dowel hole option is provided as standard for long stroke.
- Note 9: Refer to page 36 for cylinder model numbers.

<Example of model number>

LCX-Q-25L-100-T2H-R-S1T

Model: Linear slide cylinder double acting / position locking type LCX-Q

- A Bore size : $\varnothing 25$
- B Stroke : 100 mm
- C Switch model no. : Proximity, 2-wire type
Axial lead wire
- D Switch quantity : With one pc. on rod end
- E Other options : Rubber cushion type stopper
Stopper position (1)
Material, alloy steel (nitriding)

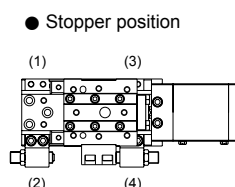

Symbol	Descriptions			
A Bore size				
25	$\varnothing 25$			
32	$\varnothing 32$			
B Stroke length (mm)				
75	75			
100	100			
125	125			
150	150			
C Switch model no.				
Axial lead wire	Radial lead wire	Contact	Indicator	Lead wire
T0H*	T0V*	Reed	One color indicator type	2-wire
T5H*	T5V*		Without indicator light	
T2H*	T2V*	Proximity	One color indicator type	2-wire
T3H*	T3V*		Two color indicator type	3-wire
T2WH*	T2WV*		Two color indicator type	2-wire
T3WH*	T3WV*		Two color indicator type	3-wire
* Lead wire length				
Blank	1 m (standard)			
3	3 m (option)			
5	5 m (option)			
D Switch quantity				
R	One on rod end			
H	One on head end			
D	Two			
E Stopper				
Blank	Without stopper			
S: Rubber cushion type stopper Note 1, Note 4, Note 7				
S1*	Stopper position (1)			Stopper installation position
S2*	Stopper position (2)			
M: Metal type stopper Note 1, Note 3, Note 4, Note 5, Note 7				
M1*	Stopper position (1)			Stopper installation position
M2*	Stopper position (2)			
A: Shock absorber type stopper Note 2, Note 4, Note 7				
A1*	Stopper position (1)			Stopper installation position
A2*	Stopper position (2)			
* Section				
Blank	Material of stopper block: Rolled steel			
T	Material of stopper block: Alloy steel (nitriding) Note 6			

How to order switch

SW - T2H3

Switch model no.
(© at page 34)

How to order stopper set

- A set of a stopper section and a rubber cushion stopper, a metal type stopper, or a shock absorber stoppers
- Used when changing from the standard to a rubber cushion stopper, a metal type stopper, or a shock absorber stopper

LCX - 25 - S 2 - S02

Bore size
(A at page 34)

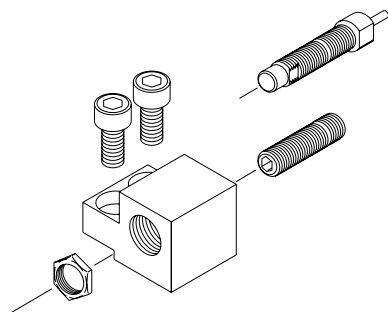

Note 1: Not selectable for shock absorber type stopper "A".

A Stopper type	
S	Rubber cushion type stopper
M	Metal type stopper
A	Shock absorber type stopper
B Stopper installation position	
1	Stopper position (1)
2	Stopper position (2)
C Adjustable stroke length Note 1	
Blank	Adjustable stroke range 10 mm
S02	Adjustable stroke range 20 mm

How to order rubber cushion type stopper

- Hexagon socket head set screw with urethane rubber
- Use for changing the adjustable stroke range or setting to the middle stroke

LCX - 25 - S02

Bore size
(A at page 34)

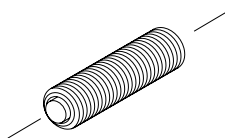

A Adjustable stroke range	
S01	Single 10 mm (standard)
S02	Single 20 mm

How to order discrete metal type stopper

- Use for changing the adjustable stroke range or setting to the middle stroke

LCX - 25 - M02

Bore size
(A at page 34)

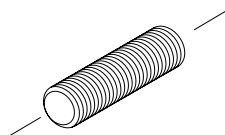

A Adjustable stroke range	
M01	Single 10 mm (standard)
M02	Single 20 mm

How to order the discrete shock absorber stopper

- A set of a shock absorber and a stopper cap
- Used when changing from a rubber cushion type or metal type stopper to a shock absorber type stopper

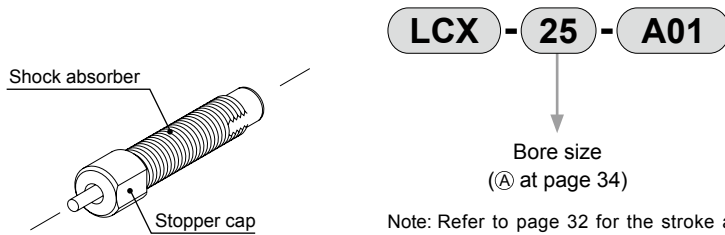

LCX - 25 - A01

Bore size
(A at page 34)

Note: Refer to page 32 for the stroke adjustment range of the shock absorber type stopper.

Applicable shock absorber model No.

Model	Shock absorber model no.
LCX-25	NCK-00-1.2
LCX-32	NCK-00-1.2

How to order stopper block discrete part

- Used when changing from the standard to a rubber cushion type stopper, a metal type stopper, or a shock absorber stopper

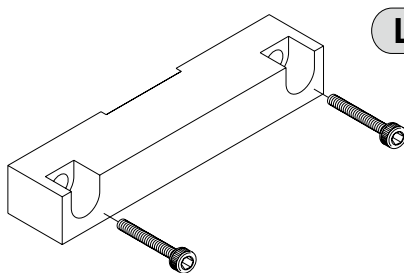

LCX - 25 L - SB3 T

Bore size
(A at page 34)

A Material	
Blank	Material of stopper block: Rolled steel
T	Material of stopper block: Alloy steel (nitriding)

How to order the positioning bolt

- Hexagon socket head cap bolt with positioning mechanism
- Cross units and 2-stage units can be assembled without position adjustment.

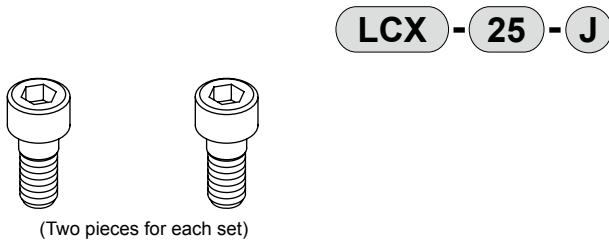

LCX - 25 - J

(Two pieces for each set)

How to order cylinder

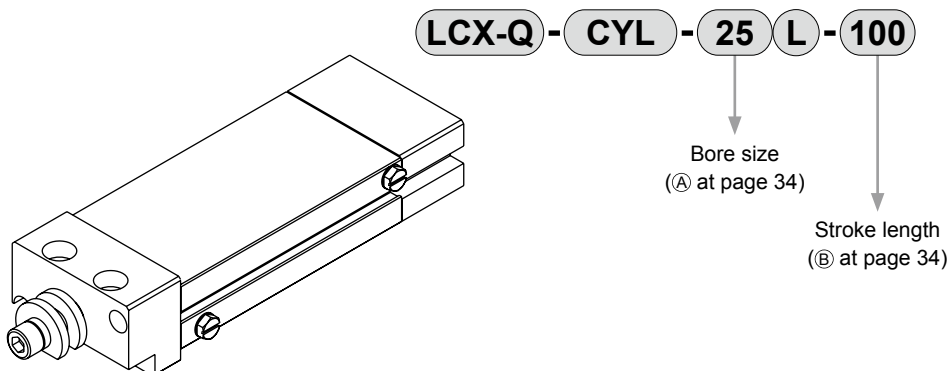

LCX-Q - CYL - 25 L - 100

Bore size
(A at page 34)

Stroke length
(B at page 34)

Internal structure and parts list

● LCX

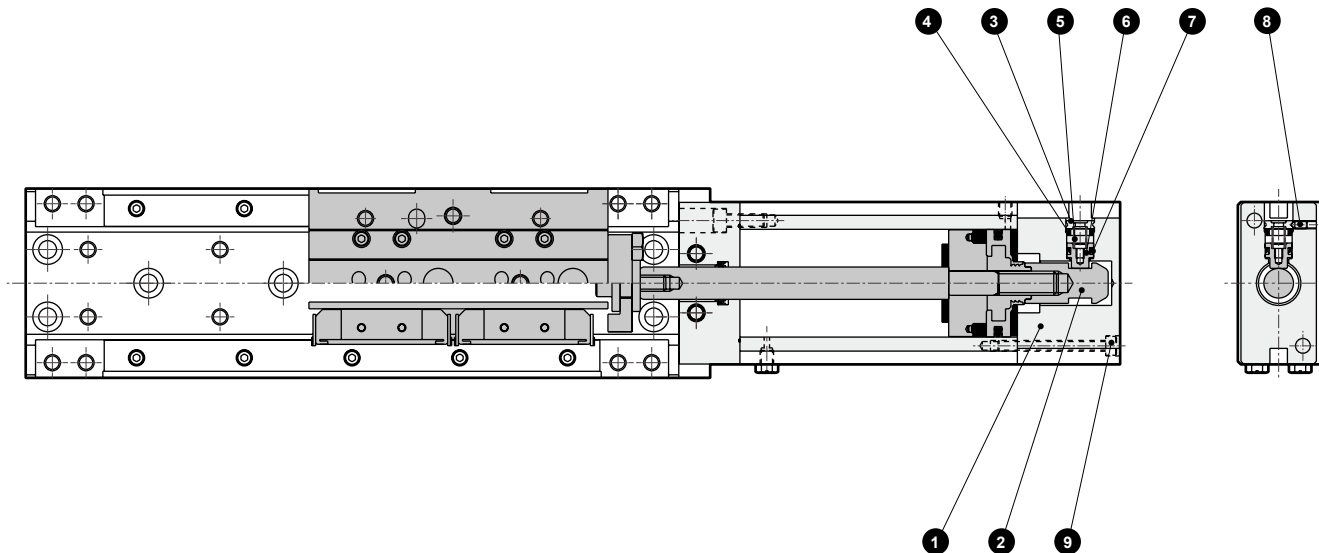

Parts list

No.	Parts name	Material	Remarks	No.	Parts name	Material	Remarks
1	Head cover	Aluminum alloy	Alumite	6	Stopper piston	Carbon steel	Nitriding
2	Sleeve	Carbon steel	Nitriding	7	Stopper packing seal	Nitrile rubber	
3	Stopper guard	Stainless steel		8	Hexagon socket head set screw	Alloy steel	Blackening
4	Cushion rubber	Urethane rubber		9	Hexagon socket head cap bolt	Alloy steel	Zinc chromate
5	Coil spring	Steel					

Repair parts list

Bore size (mm)	Kit no.	Repair parts number	
		Position locking unit repair parts	Basic unit repair parts
ø25	LCX-Q-25K		15 16
ø32	LCX-Q-32K	4 7	18 21

Note: For basic repair parts No., refer to parts list on page 29 of the double acting, single rod type, and long stroke.

Dimensions

● Double acting, position locking type, long stroke LCX-Q-*L

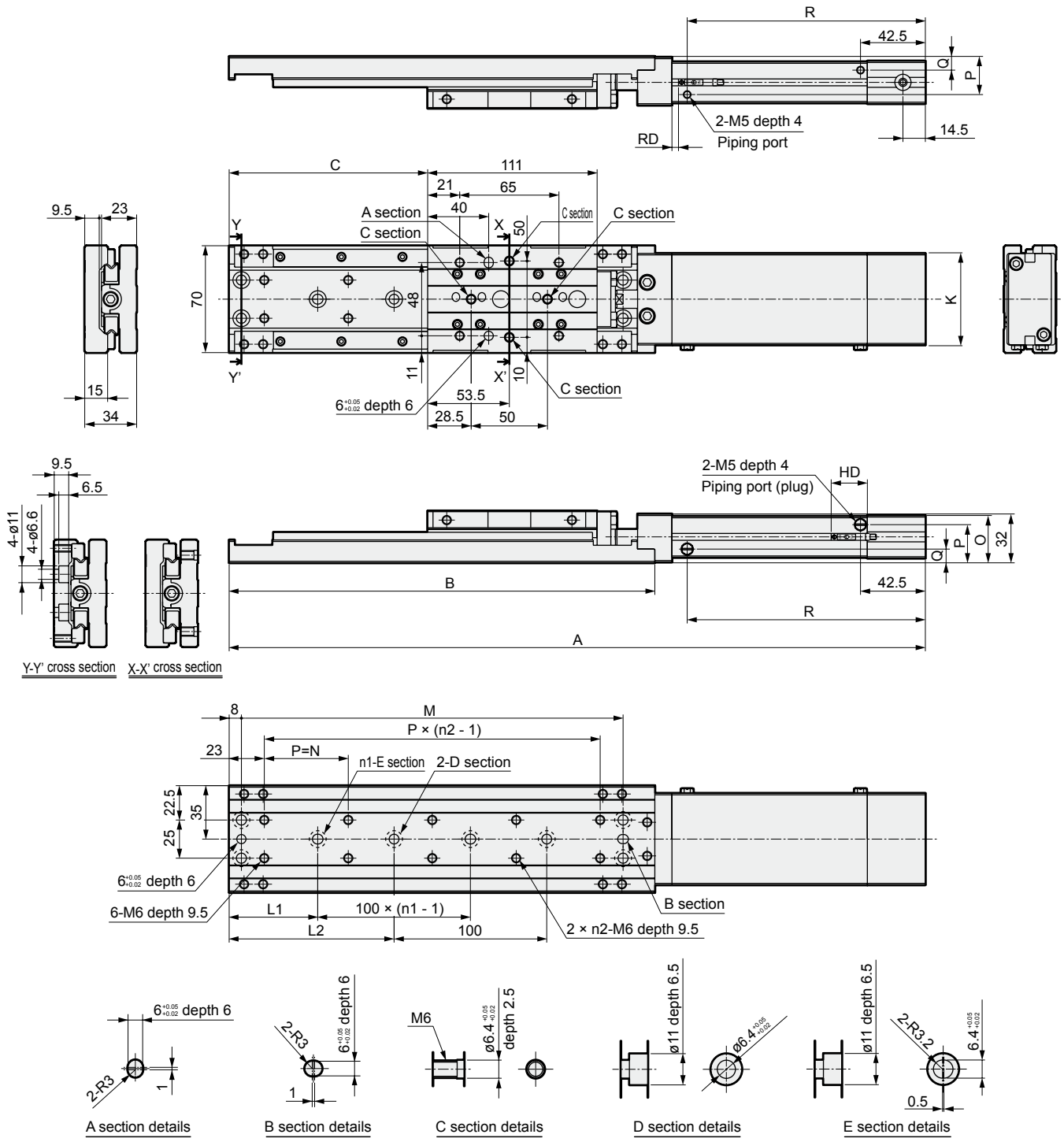

Bore size	Stroke length	A	B	C	K	L1	L2	n1	n3	M	N	O	P	Q	R	RD			HD		
																T0*	T2*	T2W*	T0*	T2*	T2W*
																T5*	T3*	T3W*	T5*	T3*	T3W*
ø25	75	406	254	105	50	45.5	95.5	2	5	225	49	29.5	24.5	9.5	131	5	6.5	23.5	21.5		
	100	456	279	130		58	108	2	5	250	55									156	
	125	506	304	155		45.5	95.5	3	6	275	49									181	
	150	556	329	180		58	108	3	6	300	54									206	
ø32	75	406	254	105	60	45.5	95.5	2	5	225	49	31	25	9	131	5	6.5	23.5	21.5		
	100	456	279	130		58	108	2	5	250	55									156	
	125	506	304	155		45.5	95.5	3	6	275	49									181	
	150	556	329	180		58	108	3	6	300	54									206	

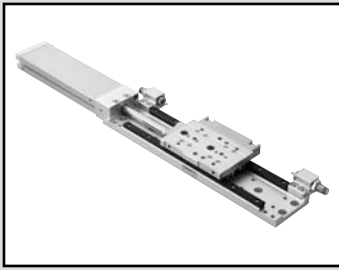

Linear slide cylinder double acting / single rod type clean room specifications / long stroke

LCX-*L-P7* Series

- Bore size: $\varnothing 25/\varnothing 32$



Specifications

Descriptions		LCX-*L-P7*	
Bore size	mm	$\varnothing 25$	$\varnothing 32$
Actuation		Double acting	
Working fluid		Compressed air	
Max. working pressure	MPa	0.7	
Min. working pressure	MPa	0.15	
Withstanding pressure	Mpa	1.05	
Ambient temperature	°C	-10 to 60 (not freezing) (Note 1)	
Port size		M5	
Relief port size		M5	
Stroke tolerance	mm	+2.0 0 (Note 2)	
Working piston speed	mm/s	20 to 500	
Cushion		Rubber cushioned	
Lubrication		Not available	
Allowable energy absorption J		Refer to table 3 on Page 46.	

Note 1: Please consult us if you use the instrument in an environment of constantly low (5°C or less) or high (40°C or over) temperature.

Note 2: When not using a stopper, a slight gap may exist between the end plate and floating bushing.

Note 3: Use the metal stopper between 20 and 200 mm/s.

Stroke length

Bore size (mm)	Standard stroke length (mm)
$\varnothing 25$	75, 100, 125, 150
$\varnothing 32$	75, 100, 125, 150

Note: Stroke length other than above is not available.

Switch specifications

* The T0/T5 switch can be used with 220 VAC.
Contact CKD for conditions.

- 1 color/2 color indicator

Descriptions	Reed 2 wire				Proximity 2 wire		Proximity 3 wire	
	T0H/T0V		T5H/T5V		T2H/T2V	T2WH/T2WV	T3H/T3V	T3WH/T3WV
Applications	Programmable controller, relay		Programmable controller, relay, IC circuit (w/o light), serial connection		Programmable controller		Programmable controller, relay	
Output method	-		-		-		NPN output	
Power voltage	-		-		-		10 to 28 VDC	
Load voltage	12/24 VDC	110 VAC	5/12/24 VDC	110 VAC	10 to 30 VDC	24 VDC \pm 10%	30 VDC or less	
Load current	5 to 50 mA	7 to 20 mA	50 mA or less	20 mA or less	5 to 20 mA		100 mA or less	50 mA or less
Light	LED (ON lighting)		Without indicator light		LED (ON lighting)	Red/green LED (ON lighting)	LED (ON lighting)	Red/green LED (ON lighting)
Leakage current	0 mA				1 mA or less		10 μ A or less	

Cylinder weight

- Clean specification

(Unit: g)

Bore size (mm)	Basic type stroke length type (mm)			
	75	100	125	150
$\varnothing 25$	1,530	1,670	1,820	1,960
$\varnothing 32$	1,660	1,810	1,960	2,110

- Additional weight for options (stopper)

(Unit: g)

Bore size (mm)	Option stopper symbol			
	S1 to S4	M1 to M4	S5/S6	M5/M6
$\varnothing 25$	320		400	
$\varnothing 32$	320		400	

How to order

Without switch



With switch



Model no.

Ⓐ Bore size

Ⓑ Stroke length

Ⓒ Switch model no.

Ⓓ Switch quantity

Ⓔ Stopper

Ⓕ Clean specification

⚠ Note on model no. selection

Note 1: Use a discrete rubber cushion type stopper or a metal type stopper on page 41 when changing the adjustable stroke range.

Note 2: Selectable only when using a stopper type.

Note 3: When using a metal type stopper, stopper block material copper alloy (symbol: T) is recommended.

Note 4: When a rubber cushion type stopper and a metal type stopper is used in combination, they are provided for each custom order.

Note 5: Use the metal stopper between 20 and 200 mm/s.

Note 6: Refer to page 42 for cylinder model numbers.

Note 7: The dowel hole option is provided as standard for long stroke.

<Example of model number>

LCX-25L-100-T2H-R-S1TP72

Model: Linear slide cylinder double acting/single rod type (clean room specifications) LCX-P7*

Ⓐ Bore size : ø25

Ⓑ Stroke : 100 mm

Ⓒ Switch model no.: Proximity, 2-wire type

Axial lead wire

Ⓓ Switch quantity : With one pc. on rod end

Ⓔ Other options : Rubber cushion type stopper
Stopper position (1)

Material, alloy steel (nitriding)

Ⓕ Clean room specifications : exhaust treatment

● Stopper position

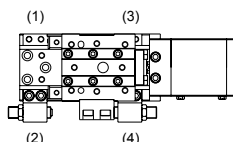

Symbol	Descriptions			
Ⓐ Bore size				
25	ø25			
32	ø32			
Ⓑ Stroke length (mm)				
75	75			
100	100			
125	125			
150	150			
Ⓒ Switch model no.				
Axial lead wire type	Lead wire L shape type	Contact	Display	Lead wire
T0H*	T0V*	Reed	One color indicator type	2-wire
T5H*	T5V*		Without indicator light	
T2H*	T2V*	Proximity	One color indicator type	2-wire
T3H*	T3V*		Two color indicator type	3-wire
T2WH*	T2WV*		Two color indicator type	2-wire
T3WH*	T3WV*		Two color indicator type	3-wire
* Lead wire length				
Blank	1 m (standard)			
3	3 m (option)			
5	5 m (option)			
Ⓓ Switch quantity				
R	One on rod end			
H	One on head end			
D	Two			
Ⓔ Stopper				
Blank	Without stopper			
S: Rubber cushion type stopper Note 1, Note 4				
S1*	Stopper position (1) (can be changed to (4))			Stopper installation position
S2*	Stopper position (2) (can be changed to (3))			
S3*	Stopper position (3) (can be changed to (2))			
S4*	Stopper position (4) (can be changed to (1))			
S5*	Stopper position (1), (3)			
S6*	Stopper position (2), (4)			
M: Metal type stopper Note 1, Note 3, Note 4, Note 5				
M1*	Stopper position (1) (can be changed to (4))			Stopper installation position
M2*	Stopper position (2) (can be changed to (3))			
M3*	Stopper position (3) (can be changed to (2))			
M4*	Stopper position (4) (can be changed to (1))			
M5*	Stopper position (1), (3)			
M6*	Stopper position (2), (4)			
* Section				
Blank	Material of stopper block: Rolled steel			
T	Material of stopper block: Alloy steel (nitriding) Note 2			
Ⓕ Clean specification				
Structure				
P72	Exhaust treatment			
P73	Vacuum treatment			

How to order switch

SW - T2H3

Switch model no.
(© at page 40)

How to order stopper set

- A set of a stopper section and a rubber cushion stopper or a metal type stopper
- Used when changing from the standard to a rubber cushion type stopper or a metal type stopper

LCX - 25 - S 2 - S02

Bore size
(A at page 40)

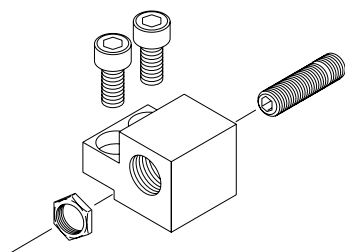

A Stopper type	
S	Rubber cushion type stopper
M	Metal type stopper
B Stopper installation position	
1	For stopper position (1) or (4)
2	For stopper position (2) or (3)
C Adjustable stroke length Note 1	
Blank	Adjustable stroke range 10 mm
S02	Adjustable stroke range 20 mm

How to order rubber cushion type stopper

- Hexagon socket head set screw with urethane rubber
- Use for changing the adjustable stroke range or setting to the middle stroke

LCX - 25 - S02

Bore size
(A at page 40)

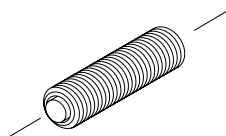

A Adjustable stroke range	
S01	Single 10 mm (standard)
S02	Single 20 mm

How to order discrete metal type stopper

- Use for changing the adjustable stroke range or setting to the middle stroke

LCX - 25 - M02

Bore size
(A at page 40)

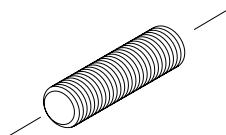

A Adjustable stroke range	
M01	Single 10 mm (standard)
M02	Single 20 mm

How to order stopper block discrete part

- Used when changing from the standard to a rubber cushion type stopper or a metal type stopper

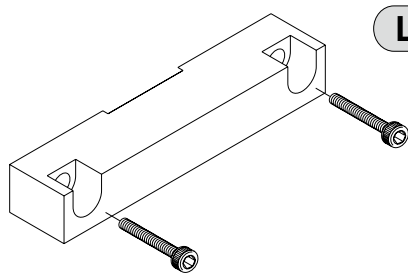

LCX - 25 L - SB3 T

Bore size
(A at page 40)

A Material	
Blank	Material of stopper block: Rolled steel
T	Material of stopper block: Alloy steel (nitriding)

How to order the positioning bolt

- Hexagon socket head cap bolt with positioning mechanism
- Cross units and 2-stage units can be assembled without position adjustment.

LCX - 25 - J

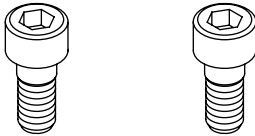

(Two pieces for each set)

How to order cylinder

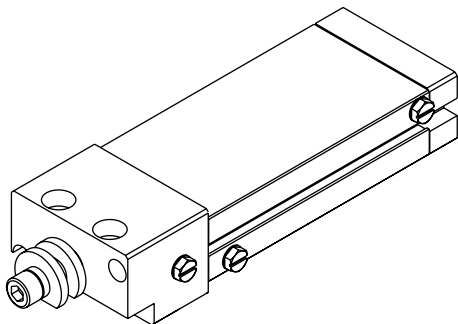

LCX - CYL - 25 L - 100 - P72

Bore size
(A at page 40)

Stroke length
(B at page 40)

A Variation	
P72	Clean room specifications (exhaust treatment)
P73	Clean room specifications (vacuum treatment)

LCX-*L-P7* Series

Dimensions

● Double acting, single rod type, clean room specifications, long stroke LCX-*L-P7*

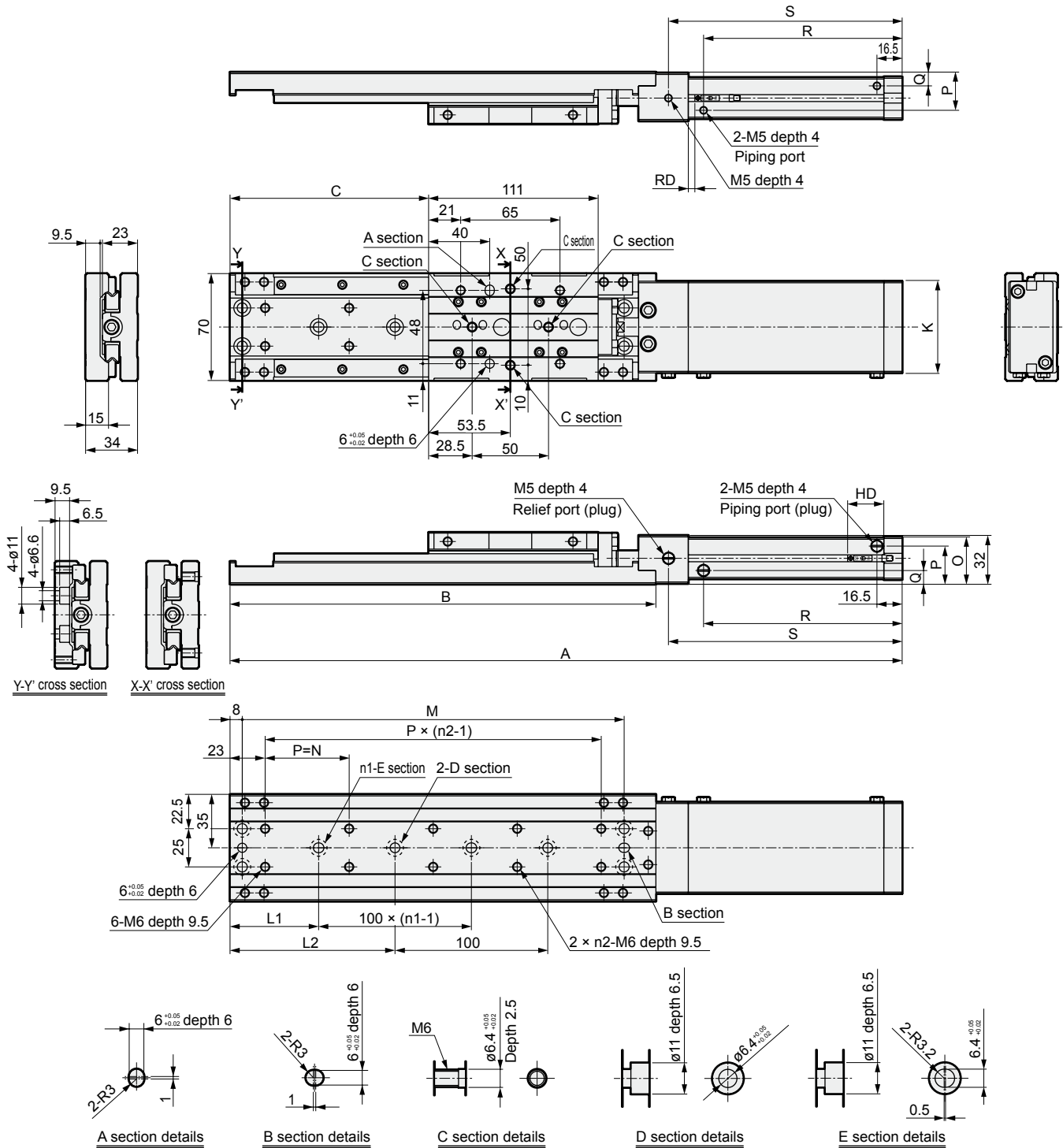

Bore size	Stroke length	A	B	C	K	L1	L2	n1	n3	M	N	O	P	Q	R	S	RD			HD						
																	T0*	T2*	T2W*	T0*	T2*	T2W*				
																	T5*	T3*	T3W*	T5*	T3*	T3W*				
ø25	75	390	254	105	50	45.5	95.5	2	5	225	49	29.5	24.5	9.5	105	128	5	6.5	23.5	21.5						
	100	440	279	130		58	108	2	5	250	55												130	153		
	125	490	304	155		45.5	95.5	3	6	275	49														155	178
	150	540	329	180		58	108	3	6	300	54															
ø32	75	390	254	105	60	45.5	95.5	2	5	225	49	31	25	9	105	128	5	6.5	23.5	21.5						
	100	440	279	130		58	108	2	5	250	55												130	153		
	125	490	304	155		45.5	95.5	3	6	275	49														155	178
	150	540	329	180		58	108	3	6	300	54															

Unit example

● Cross unit

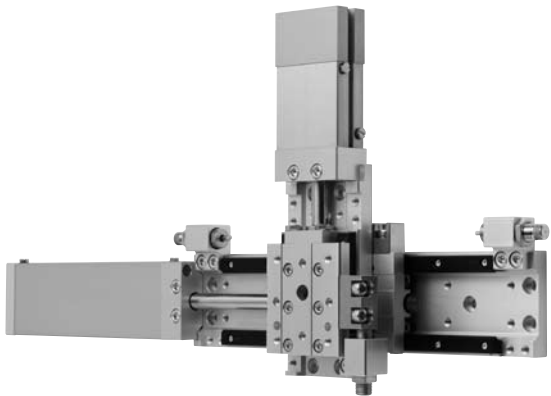

How to assemble

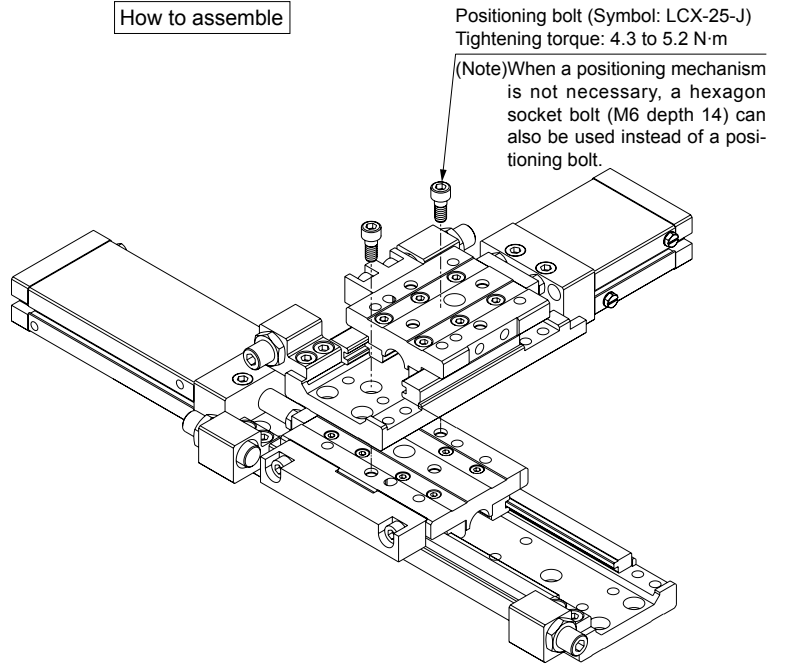

● 2-stage unit

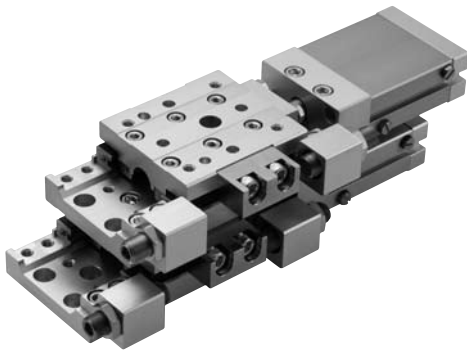

How to assemble

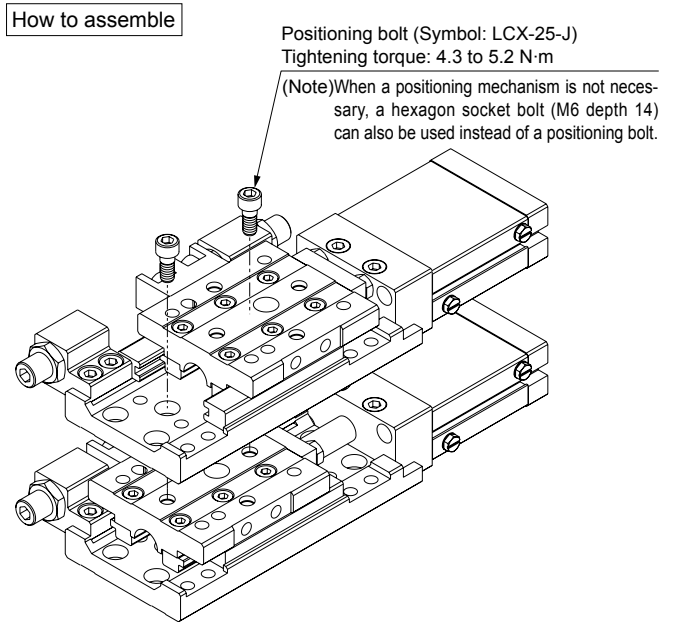

<Fitting by a positioning bolt>

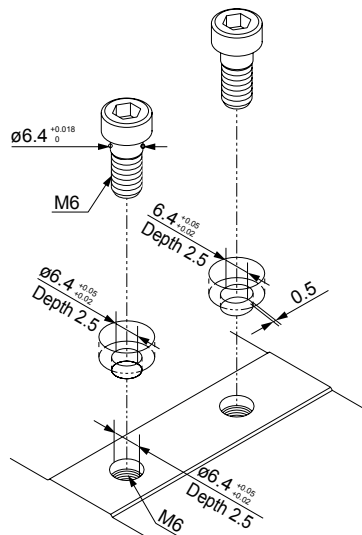

STEP-1

Check the load factor and determine the bore size.

$$\alpha = \frac{F_0}{F} \times 100 [\%]$$

α : Load factor

F_0 : Force required to move the workpiece (N)

F : Cylinder logical thrust (N)

[Table 1]

At horizontal operation	At vertical operation
$F_0 = Fw$	$F_0 = W + FW$
FW: $W \times 0.2$ (N) W: Load (N)	

Note: Coefficient of friction

[Table 1] Theoretical thrust table

(Unit: N)

Bore size	Operating direction	Working pressure MPa						
		0.15	0.2	0.3	0.4	0.5	0.6	0.7
ø25 or equivalent	PUSH	74	99	148	197	246	296	345
	PULL	57	76	114	152	190	228	266
ø32 or equivalent	PUSH	116	155	233	310	388	466	543
	PULL	99	133	199	265	332	398	464

[Table 2] Reference load factor

Working pressure MPa	Load factor (%)
0.2 to 0.3	$\alpha \leq 40$
0.3 to 0.6	$\alpha \leq 50$
0.6 to 0.7	$\alpha \leq 60$

STEP-2

Obtain the speed at stroke end (V_m) and G coefficient.

Obtain the speed at the stroke end (V_m) and G coefficient using the average speed (V_a) and load factor obtained in STEP-1.

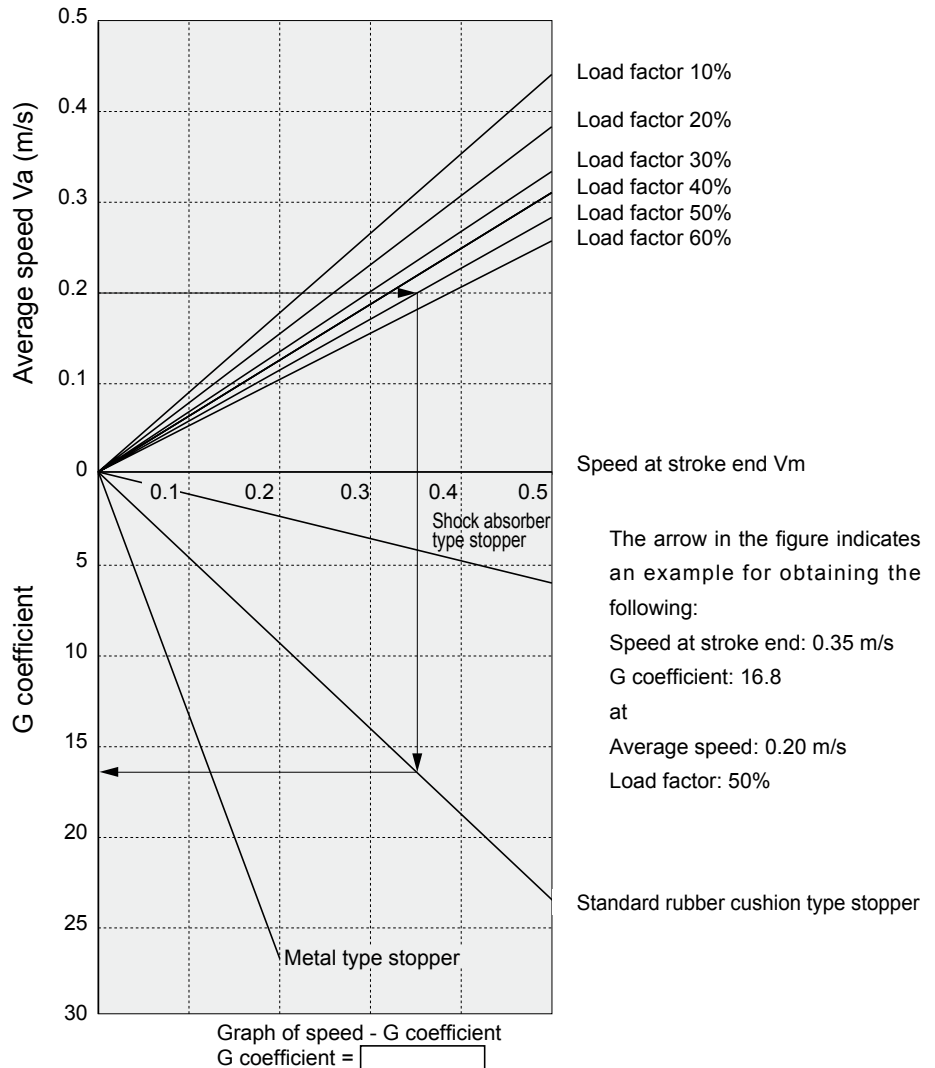

STEP-3

Check the allowable energy absorption.

$$E = \frac{1}{2} \times (m + m_a) \times Vm^2$$

E : Kinetic energy (J) at the the workpiece end

m : Weight (kg) of the load ($m \approx \frac{W (N)}{9.8}$)

m_a : Table weight (from Table 4)

Vm : Stroke end speed (m/s)

E max : E_0 maximum tolerance (from Table 3)

[Table 3] LCX allowable energy absorption (E_0)

Bore size	Standard type (J)	Rubber cushion type stopper (J)	Metal type stopper (J)	Shock absorber type stopper (J)
ø25	0.34	0.14	0.07	1.3
ø32				

[Table 4] Table weight

(Unit: kg)

Bore size	Stroke (mm)									
	10	20	30	40	50	75	100	125	150	
ø25	0.030					0.035				
ø32	0.030					0.035				

Confirm that $E \leq E_{max}$.

STEP-4

Confirm the composite moment M_T during rest.

Obtain the static load (moment) and impact moment at the stroke end in order to find the static composite moment M_T .

- Vertical load: W' (N)

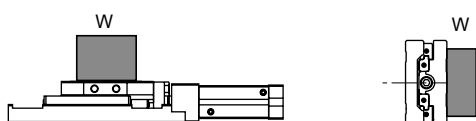

$$W' = W$$

- Radial moment: $M1'$ (N·m)

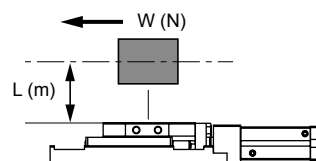

$$M1' = L \times W$$

- Radial moment: $M2'$ (N·m)

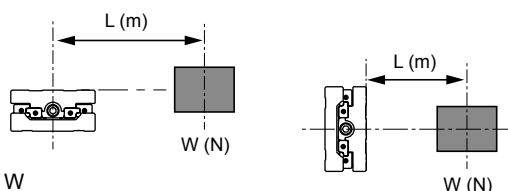

$$M2' = L \times W$$

- Twist moment: $M3'$ (N·m)

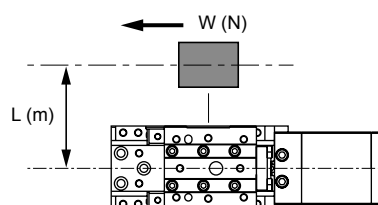

$$M3' = L \times W$$

$$W' = \text{[] (N)}$$

$$M1' \times G = \text{[] (N·m)}$$

$$M2' = \text{[] (N·m)}$$

$$M3' \times G = \text{[] (N·m)}$$

$$M_T = \frac{W'}{W'_{max}} + \frac{M1' \times G}{M1'_{max}} + \frac{M2'}{M2'_{max}} + \frac{M3' \times G}{M3'_{max}} = \text{[]}$$

M_T : Composite moment

G : G coefficient

W'_{max} : W' maximum tolerance (from Table 5)

$M1'_{max}$: $M1'$ maximum tolerance (from Table 5)

$M2'_{max}$: $M2'$ maximum tolerance (from Table 5)

$M3'_{max}$: $M3'$ maximum tolerance (from Table 5)

[Table 5] Static load tolerance

Bore size	Stroke length	Vertical load W'_{max} (N)	Bending moment $M1'_{max}$ (N·m)	Radial moment $M2'_{max}$ (N·m)	Twist moment $M3'_{max}$ (N·m)
ø25	10, 20, 30, 40, 50	670	52	110	52
ø32					
ø25	75, 100, 125, 150	970	128	116	128
ø32					

Confirm that $M_T \leq 1$.

STEP-5

Check the composite moment M_T when traveling. (Note that this value differs from the one found at STEP-4.)

● Vertical load: W (N)

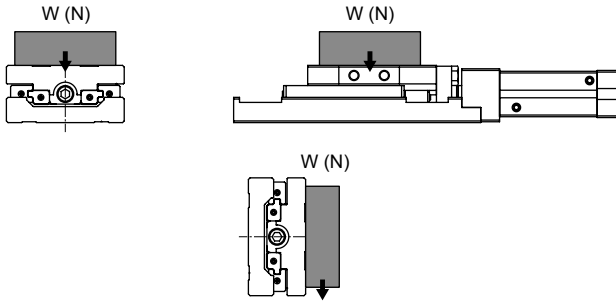

● Bending moment: M_1 (N·m)

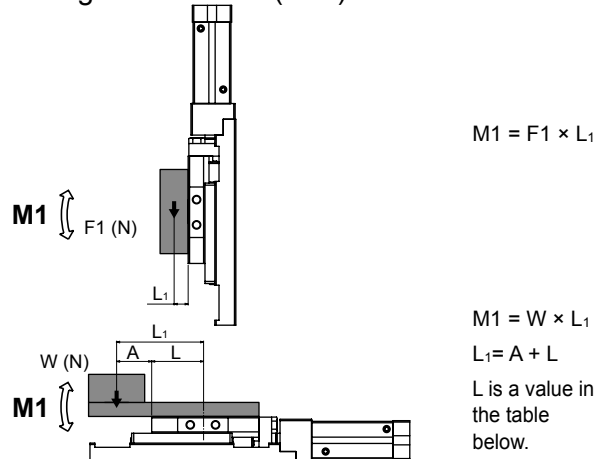

● Radial moment: M_2 (N·m)

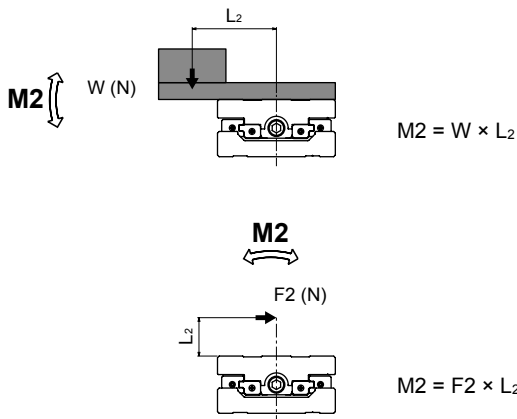

● Twist moment: M_3 (N·m)

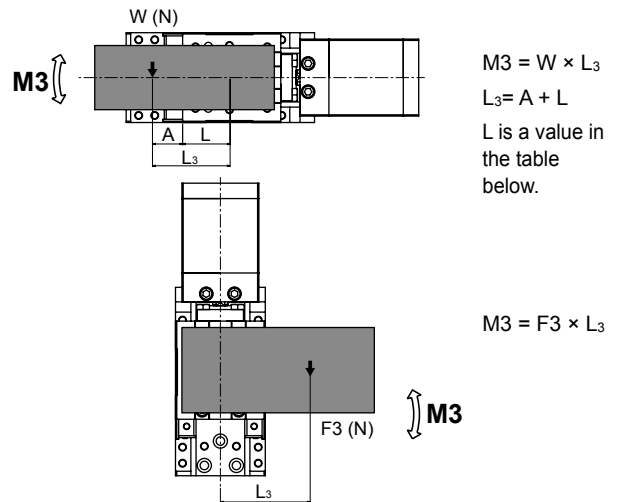

Value of L (distance from the table end to the bearing center)

Unit (m)

Bore size	Stroke length									
	10	20	30	40	50	75	100	125	150	
ø25	0.037			0.042			0.054			
ø32										

$W = W$ = (N)

M_T : Composite moment

$M_1 = M_1$ = (N·m)

W_{max} : Maximum allowable value of W (from Table 7)

$M_2 = M_2$ = (N·m)

M_{1max} : Maximum allowable value of M_1 (from Table 7)

$M_3 = M_3$ = (N·m)

M_{2max} : Maximum allowable value of M_2 (from Table 7)

$M_T = \frac{W}{W_{max}} + \frac{M_1}{M_{1max}} + \frac{M_2}{M_{2max}} + \frac{M_3}{M_{3max}} =$

M_{3max} : Maximum allowable value of M_3 (from Table 7)

[Table 7] Allowable traveling load value

Bore size	Stroke length	Vertical load W_{max} (N)	Bending moment M_{1max} (N·m)	Radial moment M_{2max} (N·m)	Twist moment M_{3max} (N·m)
ø25	10, 20, 30, 40, 50	97	7	15	7
ø32					
ø25	75, 100, 125, 150	130	17	16.5	17
ø32					

Available if $M_T \leq 1$.

Displacement at point A

[Amount of table displacement caused by M1, M2, and M3 moments]

M1 moment: displacement amount at table end when load (F1) is applied on table end

M2 moment: displacement amount at table end (A section) when load (F2) is applied at position separated 100 mm from center of cylinder

M3 moment: table displacement angle when rotary moment (M3) is applied on cylinder

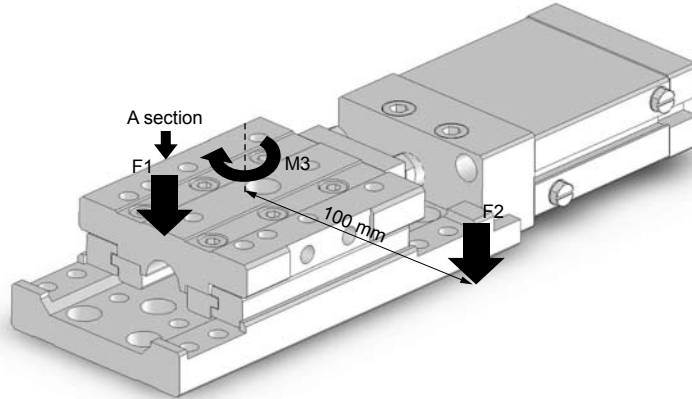

Amount of table displacement caused by M1 moment

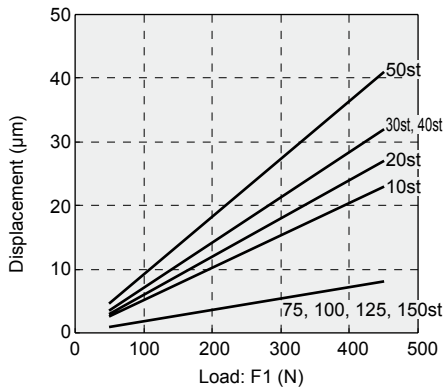

Amount of table displacement caused by M2 moment

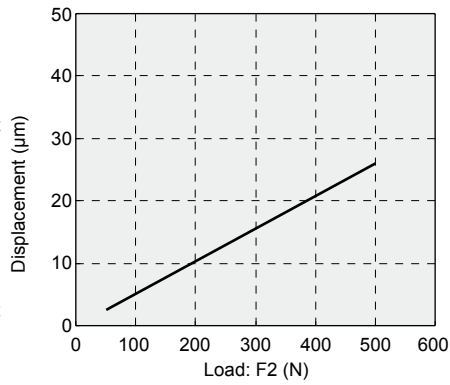
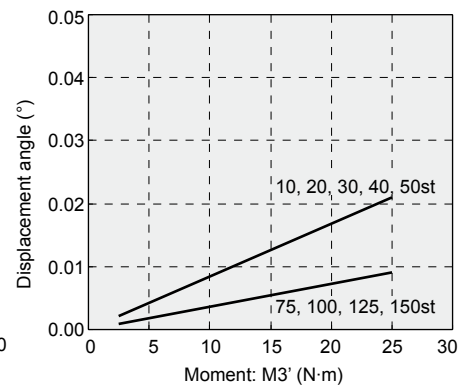
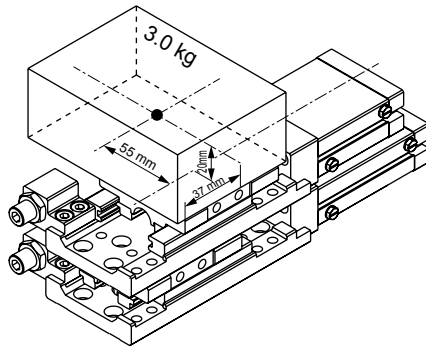

Table displacement angle caused by M3 moment



Selection guide: selection example ①



(Operation condition)

Model (top): LCX-25-30-M6 (product weight: 1,270 (g))

(bottom): LCX-32-50-S6 (product weight: 1,290 (g))

(joint): LCX-25-J (weight: 10 (g))

Pressure: 0.5 (MPa)

Workpiece weight: 3.0 (kg)

Operating direction: horizontal

Average speed (top): 100 (mm/s)

(bottom): 220 (mm/s)

Workpiece shape: Figure on the left.

STEP-1

Confirmation of load factor and determination of bore size (See page 45 for calculation details.)

Formula

$$\alpha = \frac{F_0}{F} \times 100 [\%]$$

α : Load factor

F_0 : Force required to move the workpiece (N)

F : Cylinder theoretical thrust (N)

Selection example

<Top cylinder>

$$\alpha_1 = \frac{(3.0 \times 9.8) \times 0.2}{190} \times 100 = 3.1\%$$

<Bottom cylinder>

$$\alpha_2 = \frac{\{(3.0 + 1.27 + 0.01) \times 9.8\} \times 0.2}{332} \times 100 = 2.5\%$$

Reference load factor for 0.5 MPa is $[\alpha \leq 50]$; and therefore the model is available.

STEP-2

Confirmation of speed at stroke end and coefficient G (See page 45 for calculation details.)

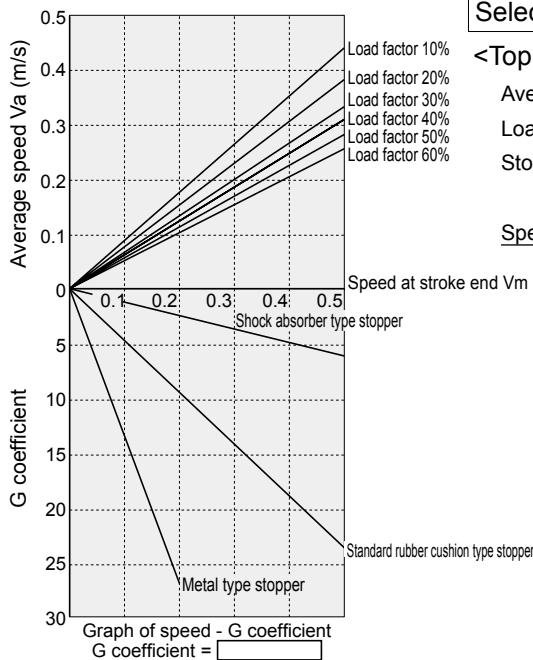

Selection example

<Top cylinder>

Average speed: 100mm/s

Load factor: 10% or less (3.1%)

Stopper: Metal type stopper

Speed at stroke end: 110 mm/s

G coefficient: 14

<Bottom cylinder>

Average speed: 220 mm/s

Load factor: 10% or less (2.5%)

Stopper: Rubber cushion type stopper

Speed at stroke end: 250 mm/s

G coefficient: 12

STEP-3

Confirmation of allowable energy absorption (See page 46 for calculation details.)

Formula

$$E = \frac{1}{2} \times (m + m_a) \times Vm^2$$

E : Kinetic energy (J) at the the work end

m : Weight (kg) of the load

m_a : Table weight (kg)

Vm : Speed at stroke end (m/s)

Selection example

<Top cylinder>

$$E = \frac{1}{2} \times (3.0 + 0.03) \times 0.11^2 = 0.02 \text{ (J)}$$

Allowable energy absorption of a metal type stopper is "0.07 J", and therefore the model is available.

<Bottom cylinder>

$$E = \frac{1}{2} \times (3.0 + 1.27 + 0.01 + 0.035) \times 0.25^2 = 0.135 \text{ (J)}$$

Allowable energy absorption of a rubber cushion type stopper is "0.14 J", and therefore the model is available.

STEP-4 Confirmation of static load allowable (See page 46 for calculation details.)

Formula

- Vertical load
 $W' = W$
- Bending moment: $M1'$ (N·m)
 $M1' = L_1 \times W$
- Radial moment: $M2'$ (N·m)
 $M2' = L_2 \times W$
- Twist moment: $M3'$ (N·m)
 $M3' = L_3 \times W$
- ◎ Moment composition

$$M'T = \frac{W'}{W'max} + \frac{M1' \times G}{M1'max} + \frac{M2'}{M2'max} + \frac{M3' \times G}{M3'max}$$

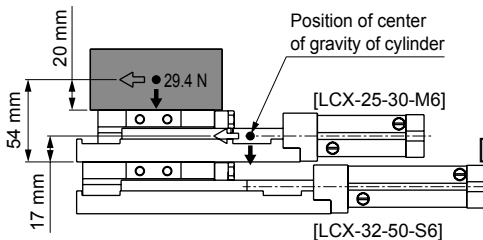

Selection example

[Calculation of load/moment]

<Top cylinder>

$$\begin{aligned} W' &= 3.0 \times 9.8 = 29.4 \text{ (N)} \\ M1' &= 0.02 \times 29.4 = 0.6 \text{ (N·m)} \\ M2' &= 0.055 \times 29.4 = 1.6 \text{ (N·m)} \\ M3' &= 0.055 \times 29.4 = 1.6 \text{ (N·m)} \end{aligned}$$

<Bottom cylinder>

$$\begin{aligned} W' &= 3.0 \times 9.8 + 1.27 \times 9.8 \\ &= 41.8 \text{ (N)} \\ M1' &= 0.054 \times 29.4 + 0.017 \\ &\quad \times 1.27 \times 9.8 \\ &= 1.8 \text{ (N·m)} \end{aligned}$$

(The top cylinder also has moment and therefore is added.)

$$\begin{aligned} M2' &= 0.055 \times 29.4 = 1.6 \text{ (N·m)} \\ M3' &= 0.055 \times 29.4 = 1.6 \text{ (N·m)} \end{aligned}$$

[Moment composition when the top cylinder operates]

Speed at stroke end: 110 mm/s G coefficient: 14

<Top cylinder>

$$M'T = \frac{29.4}{670} + \frac{0.6 \times 14}{52} + \frac{1.6}{110} + \frac{1.6 \times 14}{52} = 0.7$$

Composite moment ($M'T$) is less than "1" and therefore the model is available.

<Bottom cylinder>

$$M'T = \frac{41.8}{670} + \frac{1.8 \times 14}{52} + \frac{1.6}{110} + \frac{1.6 \times 14}{52} = 1.0$$

Composite moment ($M'T$) is less than "1" and therefore the model is available.

[Moment composition when the bottom cylinder operates]

Speed at stroke end: 250mm/s G coefficient: 12

<Top cylinder>

$$M'T = \frac{29.4}{670} + \frac{0.6 \times 12}{52} + \frac{1.6}{110} + \frac{1.6 \times 12}{52} = 0.6$$

Composite moment ($M'T$) is less than "1" and therefore is available.

<Bottom cylinder>

$$M'T = \frac{41.8}{670} + \frac{1.6 \times 12}{52} + \frac{1.6}{110} + \frac{1.6 \times 12}{52} = 0.8$$

Composite moment ($M'T$) is less than "1" and therefore is available.

STEP-5 Confirmation of allowable traveling load value (See page 47 for calculation details.)

Formula

- Vertical load
 $W = W$
- Bending moment: $M1$ (N·m)
 $M1 = L_1 \times W$
- Radial moment: $M2$ (N·m)
 $M2 = L_2 \times W$
- Twist moment: $M3$ (N·m)
 $M3 = L_3 \times W$
- ◎ Moment composition

$$M'T = \frac{W}{Wmax} + \frac{M1}{M1max} + \frac{M2}{M2max} + \frac{M3}{M3max}$$

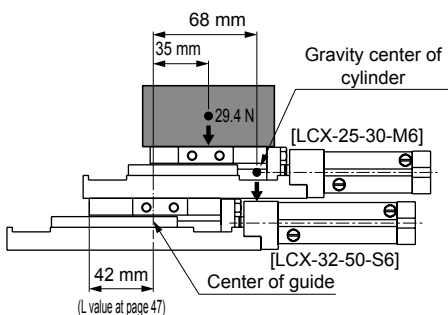

Selection example

<Top cylinder>

$$\begin{aligned} W &= 3.0 \times 9.8 = 29.4 \text{ (N)} \\ M1 &= 0 \text{ (N·m)} \\ M2 &= 0.055 \times 29.4 = 1.6 \text{ (N·m)} \\ M3 &= 0 \text{ (N·m)} \\ M'T &= \frac{29.4}{97} + \frac{0}{7} + \frac{1.6}{15} + \frac{0}{7} \\ &= 0.4 \end{aligned}$$

Composite moment ($M'T$) is less than "1" and therefore is available.

<Bottom cylinder>

$$\begin{aligned} W &= 3.0 \times 9.8 + 1.27 \times 9.8 \\ &= 41.8 \text{ (N)} \\ M1 &= 0.035 \times 29.4 + 0.068 \times 1.27 \\ &= 1.1 \text{ (N·m)} \end{aligned}$$

(The top cylinder also has moment and therefore is added. The center of gravity of the cylinder is calculated by its dimensions.)

$$\begin{aligned} M2 &= 0.055 \times 29.4 = 1.6 \text{ (N·m)} \\ M3 &= 0 \text{ (N·m)} \\ M'T &= \frac{41.8}{97} + \frac{1.1}{7} + \frac{1.6}{15} + \frac{0}{7} \\ &= 0.7 \end{aligned}$$

Composite moment ($M'T$) is less than "1" and therefore is available.

Selection guide: selection example ②

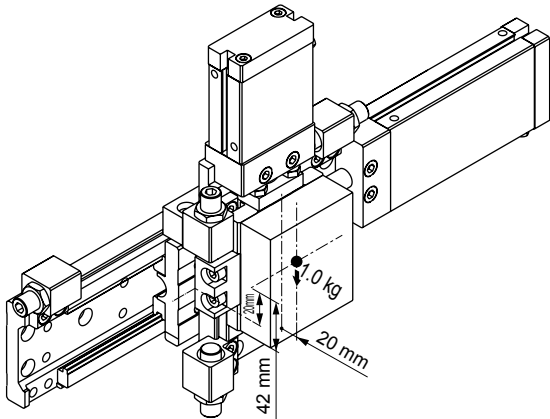

<Operation condition>

Model (X axis): LCX-32-150-A6 (product weight: 2,500 (g))
 (Z axis): LCX-32-50-S6 (product weight: 1,290 (g))
 (joint): LCX-25-J (weight: 10 (g))
 Pressure: 0.5 (MPa)
 Workpiece weight: 1.0 (kg)
 Operating direction: horizontal + vertical
 Average speed (X axis): 300 (mm/s)
 (Z axis): 50 (mm/s)
 Workpiece shape: figure on the left

STEP-1 Confirmation of load factor and determination of bore size (See page 45 for calculation details.)

Formula

$$\alpha = \frac{F_0}{F} \times 100 [\%]$$

α : Load factor

F_0 : Force required to move the workpiece (N)

F : Cylinder logical thrust (N)

Selection example

<X axis cylinder>

$$\alpha 1 = \frac{\{(1.0 + 1.29 + 0.01) \times 9.8\} \times 0.2}{332} \times 100 = 1.4\%$$

<Z axis cylinder>

$$\alpha 2 = \frac{(1.0 \times 9.8)}{332} \times 100 = 2.9\%$$

Reference load factor for 0.5 MPa is $[\alpha \leq 50]$; and therefore the model is available.

STEP-2 Confirmation of speed at stroke end and G coefficient (See page 45 for calculation details.)

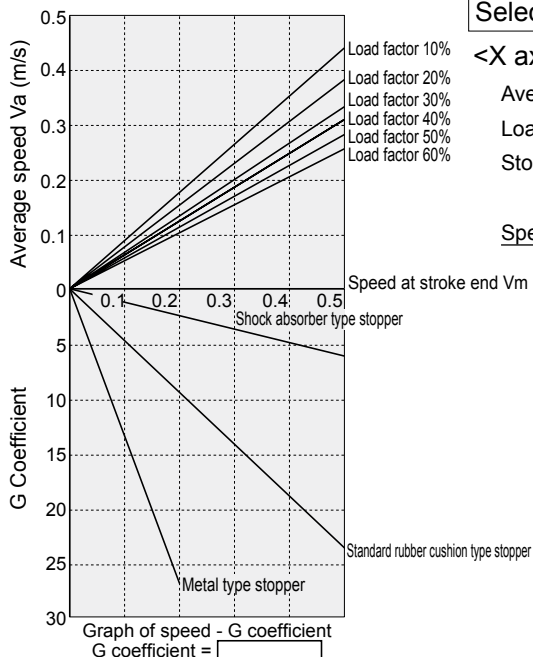

Selection example

<X axis cylinder>

Average speed: 300 mm/s
 Load factor: 10% or less (1.4%)
 Stopper: shock absorber type stopper

Speed at stroke end: 340 mm/s

G Coefficient: 4

<Z axis cylinder>

Average speed: 50 mm/s
 Load factor: 10% or less (2.9%)
 Stopper: Rubber cushion type stopper

Speed at stroke end: 75 mm/s

G Coefficient: 3

STEP-3 Confirmation of allowable energy absorption (See page 46 for calculation details.)

Formula

$$E = \frac{1}{2} \times (m + m_a) \times Vm^2$$

E : Kinetic energy (J) at the the work end

m : Weight (kg) of the load

m_a : Table weight (kg)

Vm : Table weight (kg)

Selection example

<X axis cylinder>

$$E = \frac{1}{2} \times (1.0 + 1.29 + 0.01 + 0.035) \times 0.34^2 = 0.13 \text{ (J)}$$

Allowable energy absorption of a shock absorber type stopper is "1.3J", and therefore the model is available.

<Z axis cylinder>

$$E = \frac{1}{2} \times (1.0 + 0.035) \times 0.075^2 = 0.01 \text{ (J)}$$

Allowable energy absorption of a rubber cushion type stopper is "0.14 J", and therefore the model is available.

STEP-4 Confirmation of static load allowable (See page 46 for calculation details.)

Formula

- Vertical load
 $W' = W$
- Radial moment: $M1'$ (N·m)
 $M1' = L_1 \times W$
- Radial moment: $M2'$ (N·m)
 $M2' = L_2 \times W$
- Bending moment: $M3'$ (N·m)
 $M3' = L_3 \times W$
- ◎ Moment composition
$$M'T = \frac{W'}{W_{max}} + \frac{M1' \times G}{M1'_{max}} + \frac{M2'}{M2'_{max}} + \frac{M3' \times G}{M3'_{max}}$$

(Note) There may be M2-direction impact moment for a cross unit. Multiply M2' with coefficient G as necessary.

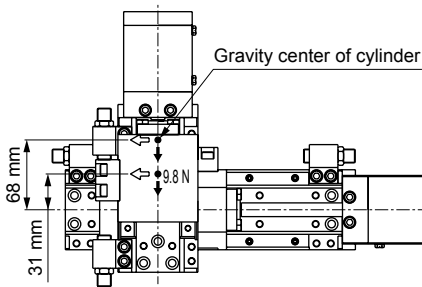

Selection example

[Calculation of load/moment]

<X axis cylinder>

$$W' = 1.0 \times 9.8 + 1.29 \times 9.8 = 22.4 \text{ (N)}$$

$$M1' = 0.054 \times 9.8 + 0.017 \times 1.29 \times 9.8 = 0.7 \text{ (N·m)}$$

(The Z axis cylinder also has moment and therefore is added.)

$$M2' = 0.054 \times 9.8 + 0.017 \times 1.29 \times 9.8 = 0.7 \text{ (N·m)}$$

$$M3' = 0.031 \times 9.8 + 0.068 \times 1.29 \times 9.8 = 1.2 \text{ (N·m)}$$

<Z axis cylinder>

$$W' = 0 \text{ (N)}$$

$$M1' = 0.02 \times 9.8 = 0.2 \text{ (N·m)}$$

$$M2' = 0.02 \times 9.8 = 0.2 \text{ (N·m)}$$

$$M3' = 0 \text{ (N·m)}$$

[Moment composition when the X axis cylinder operates]

Speed at stroke end: 340mm/s G coefficient: 4

<X axis cylinder>

$$M'T = \frac{22.4}{670} + \frac{0.7 \times 4}{128} + \frac{0.7}{116} + \frac{1.2 \times 4}{128} = 0.1$$

Composite moment (M'T) is less than "1" and therefore is available.

<Z axis cylinder>

$$M'T = \frac{0}{670} + \frac{0.2}{52} + \frac{0.2 \times 4}{110} + \frac{0}{52} = 0.01$$

(The X axis cylinder operation makes M2-direction impact moment on the Z axis cylinder, so the value is multiplied by G coefficient.)

Composite moment (M'T) is less than "1" and therefore is available.

[Moment composition when the Z axis cylinder operates]

Speed at stroke end: 75mm/s coefficient G: 3s

<X axis cylinder>

$$M'T = \frac{22.4}{970} + \frac{0}{128} + \frac{0.7 \times 3}{116} + \frac{0}{128} = 0.04$$

(The Z axis cylinder operation makes M2-direction impact moment on the X axis cylinder, so the value is multiplied by G coefficient.)

Composite moment (M'T) is less than "1" and therefore is available.

<Z axis cylinder>

$$M'T = \frac{0}{670} + \frac{0.2 \times 3}{52} + \frac{0}{110} + \frac{0}{52} = 0.01$$

Composite moment (M'T) is less than "1" and therefore is available.

STEP-5 Confirmation of allowable traveling load value (See page 47 for calculation details.)

Formula

- Vertical load
 $W = W$
- Bending moment: $M1$ (N·m)
 $M1 = L_1 \times W$
- Radial moment: $M2$ (N·m)
 $M2 = L_2 \times W$
- Twist moment: $M3$ (N·m)
 $M3 = L_3 \times W$
- ◎ Moment composition
$$M'T = \frac{W}{W_{max}} + \frac{M1}{M1_{max}} + \frac{M2}{M2_{max}} + \frac{M3}{M3_{max}}$$

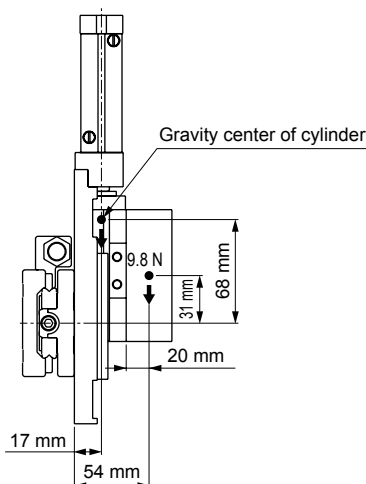

Selection example

<X axis cylinder>

$$W = 1.0 \times 9.8 + 1.27 \times 9.8 = 22.4 \text{ (N)}$$

$$M1 = 0 \text{ (N·m)}$$

$$M2 = 0.054 \times 9.8 + 0.017 \times 1.29 \times 9.8 = 0.7 \text{ (N·m)}$$

$$M3 = 0 \text{ (N·m)}$$

$$M'T = \frac{22.4}{130} + \frac{0}{17} + \frac{0.7}{16.5} + \frac{0}{17} = 0.2$$

Composite moment (M'T) is less than "1" and therefore is available.

<Z axis cylinder>

$$W = 0 \text{ (N)}$$

$$M1 = 0.02 \times 9.8 = 0.2 \text{ (N·m)}$$

$$M2 = 0 \text{ (N·m)}$$

$$M3 = 0 \text{ (N·m)}$$

$$M'T = \frac{0}{97} + \frac{0.2}{7} + \frac{0}{15} + \frac{0}{7} = 0.03$$

Composite moment (M'T) is less than "1" and therefore is available.



Safety precautions

Always read this section before starting use.

When designing and manufacturing a device using CKD products, the manufacturer is obligated to check that device safety mechanism, pneumatic control circuit, or water control circuit and the system operated by electrical control that controls the devices is secured.

It is important to select, use, handle, and maintain the product appropriately to ensure that the CKD product is used safely. Observe warnings and precautions to ensure device safety.

Check that device safety is ensured, and manufacture a safe device.

WARNING

- 1** This product is designed and manufactured as a general industrial machine part.
It must be handled by an operator having sufficient knowledge and experience in handling.
 - 2** Use this product in accordance of specifications.
This product must be used within its stated specifications. It must not be modified or machined.
This product is intended for use as a general-purpose industrial device or part. It is not intended for use outdoors or for use under the following conditions or environment.
Note that this product can be used when CKD is consulted prior to use and the customer consents to CKD product specifications. The customer must provide safety measures to avoid risks in the event of problems.
 - 1** Use for special applications requiring safety including nuclear energy, railroad, aviation, ship, vehicle, medical equipment, equipment or applications coming into contact with beverage or food, amusement equipment, emergency shutoff circuits, press machine, brake circuits, or for safeguard.
 - 2** Use for applications where life or assets could be adversely affected, and special safety measures are required.
 - 3** Observe corporate standards and regulations, etc., related to the safety of device design and control, etc.
ISO 4414, JIS B 8370 (pneumatic system rules)
JFPS (principles for pneumatic cylinder selection and use)
Including High Pressure Gas Maintenance Law, Occupational Safety and Sanitation Laws, other safety rules, body standards and regulations, etc.
 - 4** Do not handle, pipe, or remove devices before confirming safety.
 - 1** Inspect and service the machine and devices after confirming safety of the entire system related to this product.
 - 2** Note that there may be hot or charged sections even after operation is stopped.
 - 3** When inspecting or servicing the device, turn off the energy source (air supply or water supply), and turn off power to the facility. Discharge any compressed air from the system, and pay attention to possible water leakage and leakage of electricity.
 - 4** When starting or restarting a machine or device that incorporates pneumatic components, make sure that the system safety, such as pop-out prevention measures, is secured.
 - 5** Observe warnings and cautions on the pages below to prevent accidents.
- The safety cautions are ranked as “DANGER”, “WARNING” and “CAUTION” in this section.

 **DANGER:** When a dangerous situation may occur if handling is mistaken leading to fatal or serious injuries, or when there is a high degree of emergency to a warning.

 **WARNING:** When a dangerous situation may occur if handling is mistaken leading to fatal or serious injuries.

 **CAUTION:** When a dangerous situation may occur if handling is mistaken leading to minor injuries or physical damage.

Note that some items described as “CAUTION” may lead to serious results depending on the situation. In any case, important information that must be observed is explained.

Disclaimer

- 1** Term of warranty
“Warranty Period” is one (1) year from the first delivery to the customer.
- 2** Scope of warranty
In case any defect attributable to CKD is found during the Warranty Period, CKD shall, at its own discretion, repair the defect or replace the relevant product in whole or in part, according to its own judgement.
Note that the following faults are excluded from the warranty term:
 - (1) Product abuse/misuse contrary to conditions/environment recommended in its catalogs/specifications
 - (2) Failure caused by other than the delivered product
 - (3) Faults caused by improper product use.
 - (4) Third-party repair/modification
 - (5) Faults caused by matters that could not be predicted with the technology applied when the product was delivered.
 - (6) Failure attributable to force majeure.In no event shall CKD be liable for business interruptions, loss of profits, personal injury, costs of delay or for any other special, indirect, incidental or consequential losses, costs or damages.
- 3** Compatibility confirmation
In no event shall CKD be liable for merchantability or fitness for a particular purpose, notwithstanding any disclosure to CKD of the use to which the product is to be put.



Pneumatic components

Safety precautions

Always read this section before starting use.

Refer to "Pneumatic cylinders (CB-029SA)" for general details on cylinders and cylinder switches.

Individual precautions: Thin linear slide cylinder LCX Series

Design & Selection

1. Common

CAUTION

- Refer to the LCX selection guide on pages 45 to 48 when selecting the cylinder.
- When using the cylinder where it could be subject to water or oil exposure, where it could corrode, or where high levels of dust are present, the cylinder could be damaged or malfunction. Protect the product with a cover.
- Note for switch installation
 - An axial lead wire switch of 30 mm stroke or less and a radial lead wire switch of 30 mm stroke or less are installed at each of the two grooves of the body. Be careful about the removal direction of the lead wire at design time.
- When you use the instrument with a cylinder ambient temperature of 5°C or less, make sure that the supply pressure is 0.5 MPa or less.
- Please consult us if you use the instrument in an environment of constantly low (5°C or less) or high (40°C or over) temperature.
- We provide three types of stoppers with stroke length adjustment function.
 - Rubber cushion type stopper

Stopper with integrated urethane cushion rubber. Metal touch stoppers that touches with a pressure of 0.4 MPa or over are also available for stabilizing the stop position; please consult us.

- Metal type stopper

This type does not have cushion mechanism; use it with low speed and low load. This type does not have unstableness of stopping position caused by transformation of rubber cushion.

- Shock absorber type stopper

This type provides smooth stopping through high energy absorbing performance. The stopping position is determined by metal touch.

2. Position locking type LCX-Q

CAUTION

- Do not use a 3-position valve.

Do not use this cylinder combined with 3-position valve, especially that with a closed center metal seal. The lock is not applied if pressure is sealed on the port having the lock. Even if locked once, air leakage from the valve may enter the cylinder then the lock may be released over time.
- Cylinder load factor must be 50% or less.

If the load factor is high, the lock may not be released or the lock section could be damaged.

Installation & Adjustment

1. Common; piping

CAUTION

- Precautions for piping joint

Install a speed control valve when piping.
The applicable joints are shown as below.

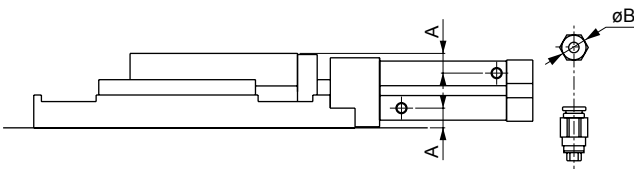

Descriptions	Port size	Port dimension A	Applicable joints	Joint O.D. B
Bores size (mm)				
ø25	M5	9.5	SC3W-M5-4 SC3W-M5-6 GWS4-M5-S GWS4-M5	ø17 or less
ø32		9	GWL4-M5 GWS6-M5-S GWS6-M5 GWL6-M5	

2. Common; Installation

CAUTION

- The base and the table fixing face of this product is finished by precise machining technology in order to achieve accurate straight movement. Therefore, stable accuracy will be achieved by finishing fixing faces of equipment with high precision flatness.
(recommended flatness: 0.01 mm or less)
Be sure not to cause dents or damage on the fixing face that could compromise flatness.

Installation & Adjustment

- Observe the following bolt insertion lengths and tightening torque when installing the jig on the table or base.

<Fig. 1>

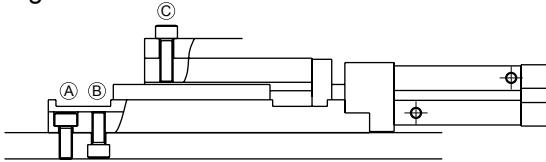

Descriptions	A		B			C		
	Applicable bolts	Tightening torque (N·m)	Applicable bolts	Tightening torque (N·m)	Max. screw length	Applicable bolts	Tightening torque (N·m)	Max. screw length
LCX-25	M6	4.3 to 5.2	M6 × 1.0	4.3 to 5.2	9.5 mm	M6 × 1.0	4.3 to 5.2	11 mm
LCX-32								

- Observe the following valves for bolts at the stopper and in nut tightening torque.

<Fig. A>

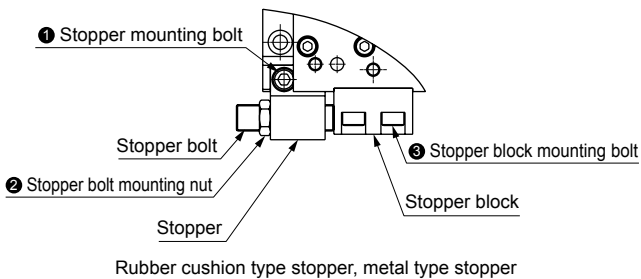
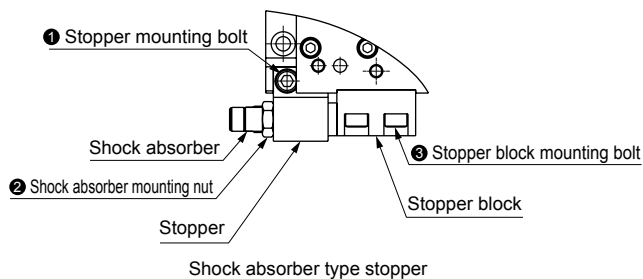

Descriptions	1 Stopper mounting bolt	2 Stopper bolt mounting nut 2 Shock absorber mounting nut	3 Stopper block mounting bolt
	(N·m)	(N·m)	(N·m)
LCX-25	4.3 to 5.2	4.5 to 6.0	4.3 to 5.2
LCX-32			

- The cylinder switch could malfunction if there is a magnetic body, such as a steel plate, near the cylinder switch. Separate the magnetic body by at least 10 mm or more from the cylinder surface, or change the cylinder switch mounting surface for safe use. (Same clearance for all bore sizes)

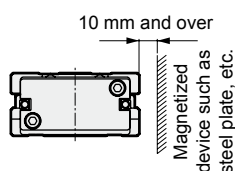

- Cylinders being adjacent may cause malfunction of the cylinder switch. Ensure the distance shown below between cylinder surfaces. (Same clearance for all bore sizes)

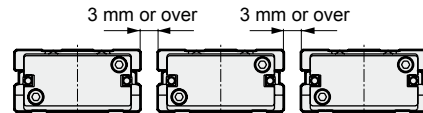

- The CKD shock absorber is treated as a consumable. Replace the shock absorber if energy absorption performance drops or if movement is no longer smooth.
- When using a dowel hole, use a pin with a size that does not fit in the pressfit. Using a pin of the pressfit size sheds load on the pressfit, which may cause damage to the linear guide or a degraded accuracy due to distortion. The recommended tolerance for a pin is JIS tolerance m6 or less.

3. Position locking type LCX-Q

CAUTION

- The locking mechanism functions at the stroke end. Do not mount a stopper at a stopper position (3) or (4). If the stopper is applied with the external stopper in the middle of a stroke, the locking mechanism will not function and the load may drop. Before setting the load, check that the locking mechanism functions correctly.
- Supply a pressure higher than the minimum working pressure to the port having the locking mechanism.
- If piping on the side with the lock is thin and long, or if the speed controller is separated from the cylinder port, exhaust may slow, taking time for the lock to function. This may also occur if the silencer on the solenoid valve's EXH. port is clogged.

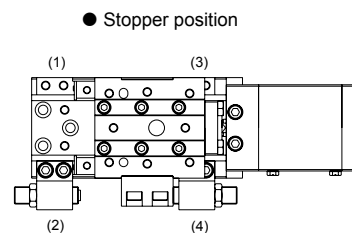

During Use & Maintenance

1. Common

⚠ CAUTION

- Apply AFF grease (THK) to guide rails every six months or every 1,000,000 operations, whichever is sooner.

2. Position locking type LCX-Q

⚠ WARNING

- If pressure is applied from port (A) in the locked state and with neither port pressurized, it may not be possible to release locks, or the lock may be released suddenly and cause the piston rod to pop out. This is extremely hazardous. When releasing the locking mechanism, supply pressure to port (B) and check that no load is applied to the locking mechanism.

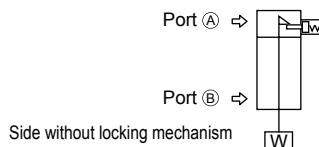

- If lowering speed is to be increased with the quick exhaust valve, the cylinder may move out faster than the lock pin and prevent the locking pin from being released correctly. Do not use a quick exhaust valve with the cylinder with position locking.

⚠ CAUTION

- If negative pressure is applied to the locking mechanism, the lock may be released. Use the solenoid valve as a discrete unit, or use an independently exhausted manifold.
- After manually operating the locking mechanism, return the locking mechanism to the original position. Do not use a manual override except during adjustment. It's dangerous.
- Release the lock when installing or adjusting the cylinder.
The lock could be damaged if the cylinder is installed while the lock is applied.
- Do not use multiple cylinders synchronized.
Do not move more than one workpiece using more than two cylinders with position locking mechanism simultaneously. One of the cylinder's locks may not be released.
- Use the speed control valve with meter-out control.
Locks may not be released during meter-in control.
- Always use up to the stroke end of the side with the lock.
If the cylinder's piston does not reach the stroke end, the lock may not be applied or may not be released.

■ How to release

Screw a hexagon socket head bolt (M3 × 25) into the stopper piston, and pull the bolt up 3 mm with a force of 20N or more. The stopper piston moves and the lock is released during horizontal no-load installation or with the rod port pressurized. When the hand is released, the stopper piston is returned by the internal spring and enters the piston rod slot, locking the cylinder.

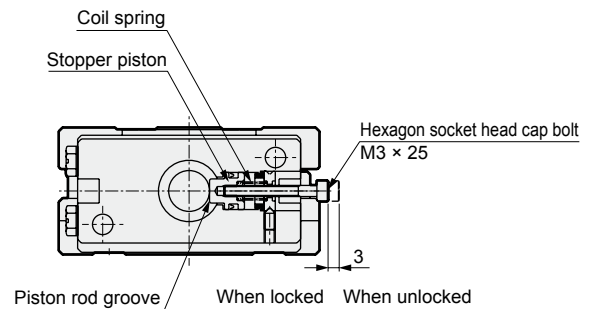

3. Long stroke LCX-*L

- An appropriate pre-load adjustment is made for the linear guide.
Do not slacken a hexagon socket head set screw or retighten it; the product performance may be reduced.

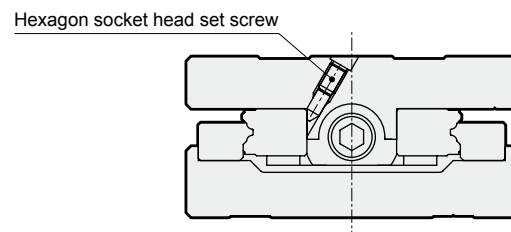

Related products

Linear slide cylinder LCR series

- Use of aluminum tables reduced its weight by 10%.
- Increased rigidity of the linear guide and slide table realized their better rigidity.
- Enhanced possibility in designing is realized by the symmetry of the stopper, multi-side piping, and positioning hole.

Catalog No. CC-996A

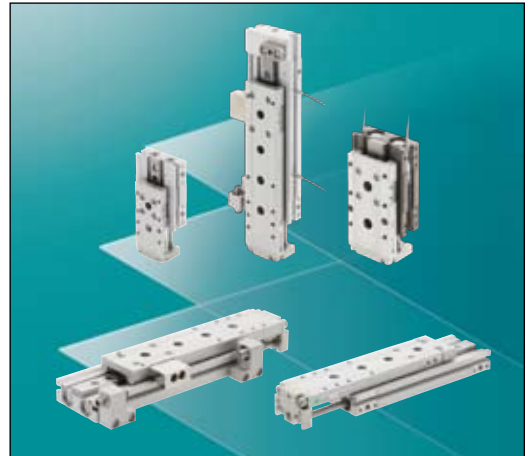

Linear slide cylinder LCG series

- The topnotch wide guide realizes the highest rigidity in the industry.
- Use of aluminum tables reduced its weight by 10%.
- Increased rigidity of the linear guide and slide table realized their better rigidity.
- Enhanced possibility in designing is realized by the symmetry of the stopper, multi-side piping, and positioning hole.

Catalog No. CB-029SA



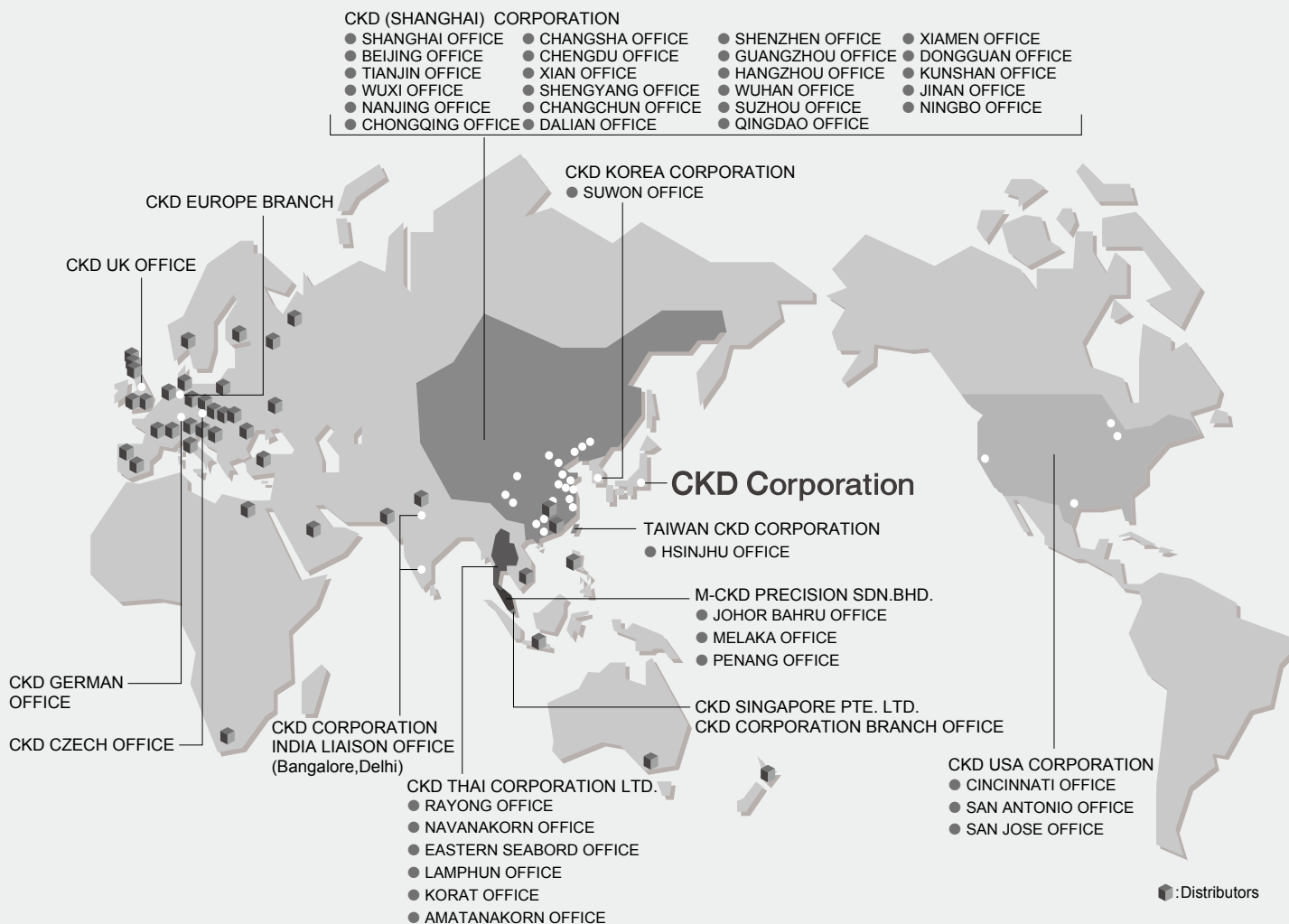

CKD Corporation

- OVERSEAS SALES ADMINISTRATION DPT.
OVERSEAS BUSINESS DIV. 2-250 Oujji Komaki, Aichi 485-8551, Japan
- PHONE +81-(0)568-74-1338 FAX +81-(0)568-77-3461

U.S.A.

CKD USA CORPORATION

- HEADQUARTERS
4080 Winnetka Avenue, Rolling Meadows, IL 60008 USA
PHONE +1-847-368-0539 FAX +1-847-788-0575

EUROPE

CKD EUROPE BRANCH

De Fruittuinen 28 Hoofddorp 2132NZ The Netherlands
PHONE +31-(0) 23-5541490 FAX +31-(0) 23-5541491

Malaysia

M-CKD PRECISION SDN.BHD.

- HEADQUARTERS
Lot No.6, Jalan Modal 23/2, Seksyen 23, Kawasan, MIEL,
Fasa 8, 40300 Shah Alam, Selangor Darul Ehsan, Malaysia
PHONE +60-(0) 3-5541-1468 FAX +60-(0) 3-5541-1533

Thailand

CKD THAI CORPORATION LTD.

- SALES HEADQUARTERS-BANGKOK OFFICE
Suwan Tower, 14/1 Soi Saladaeng 1, North Sathorn Rd., Bangrak,
Bangkok 10500 Thailand
PHONE +66-(0) 2-267-6300 FAX +66-(0) 2-267-6305

Singapore

CKD SINGAPORE PTE. LTD.

- No.33 Tannery Lane #04-01 Hoesteel Industrial Building Singapore 347789
PHONE +65-67442623 FAX +65-67442486
- CKD CORPORATION BRANCH OFFICE**
No.33 Tannery Lane #04-01 Hoesteel Industrial Building Singapore 347789
PHONE +65-67447260 FAX +65-68421022

Taiwan

TAIWAN CKD CORPORATION

16F-3, No.109, Sec.1 Jhongshan RD., Shinjhuang Dist., New Taipei City,
24250, Taiwan (R.O.C)
PHONE +886-(0) 2-8522-8198 FAX +886-(0) 2-8522-8128

China

CKD (SHANGHAI) CORPORATION

- SALES HEADQUARTERS / SHANGHAI OFFICE
Room 601, Yuan Zhong Scientific Research Building,
1905 Hongmei Road, Shanghai, 200233, China
PHONE +86-(0) 21-61911888 FAX +86-(0) 21-60905356

Korea

CKD KOREA CORPORATION

- HEADQUARTERS
3rd FL, Sam Young B/D, 371-20
Sinsu-Dong, Mapo-Gu, Seoul, 121-110, Korea
PHONE +82-(0) 2-783-5201~5203 FAX +82-(0) 2-783-5204

Website <http://www.ckd.co.jp/>

The goods and their replicas, or the technology and software in this catalog are subject to complementary export regulations by Foreign Exchange and Foreign Trade Law of Japan.

If the goods and their replicas, or the technology and software in this catalog are to be exported, laws require the exporter to make sure they will never be used for the development or the manufacture of weapons for mass destruction.