

PB, PB2 ROD CYLINDER SLIDES



CONTENTS

PB Features	PB_2
PB & PB2 Performance	PB_3
PB Performance	PB_4
PB Specifications	PB_6
PB Dimensions	PB_6
Applications	PB_8
PB2 Features	PB_9
PB2 Performance	PB_10
PB2 Specifications	PB_11
PB2 Dimensions	PB_12
Switches	PB_14
Application Data Worksheet	PB_16
Selection Guidelines	PB_17
Application Guidelines	PB_18
Service Parts	PB_19
Ordering	PB_20

ABT

MXP

BCZ

BC3

BC4

LS

MG

CC

PB

ENGR

PB POWER-BLOCK

ENDURANCE TECHNOLOGYSM

Endurance Technology features are designed for maximum durability to provide extended service life.

The Power Block rod cylinder slide features two precision steel guide rods with composite bearings to provide positive support of the load. The Power Block withstands heavy side loads making it a great choice for conveyor line stops and load lifting applications. Built-to-order in stroke lengths up to 3 inches.

DURABLE BEARING

COMPOSITE BEARINGS

- Thin profile allows use of oversize guide rods
- Best choice for impact use or high contaminant environments



DOVETAIL SLOTS

- For easy switch mounting

INTERNAL BUMPER

- Made of urethane composite to prolong cylinder life and reduce noise



NICKEL-PLATED SHAFTS

- Shafts up to 0.625" diameter

DURABLE DESIGN

- Tough, lightweight extruded aluminum in a low profile package

MOUNTING FLEXIBILITY

- Threaded holes for base or side mounting



PLATED STEEL TOOLING PLATE

- Threaded bolt thru holes for tooling plate mounting

OPTIONS



STOP COLLAR / BUMPER KIT

- Includes 2 stop collars and 1/4" thick polyurethane external bumpers to help absorb impact shock



DUAL TOOLING PLATE

- Added flexibility for many applications



SWITCHES

- Available in Reed, Hall-effect and Triac
- 15ft. cable with flying leads; available with quick-disconnect couplers

5 DAYS
BUILT-TO-ORDER

ABT
MXP
BC2
BC3
BC4
LS
MG
CC
PB
ENGR

PB & PB2 Rod Cylinder Slides - All Sizes

PERFORMANCE

THEORETICAL FORCE vs PRESSURE

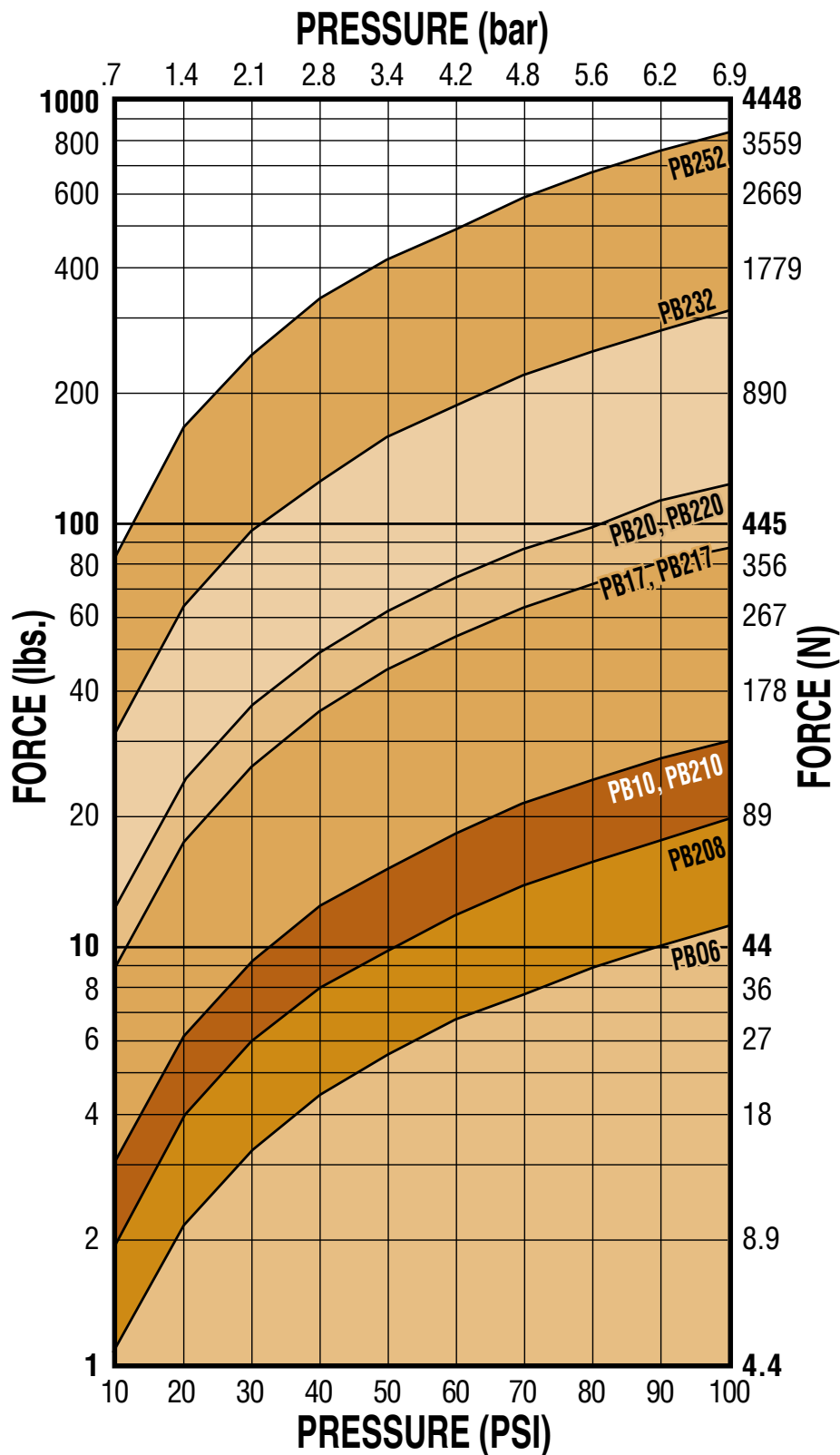

STROKE LENGTHS

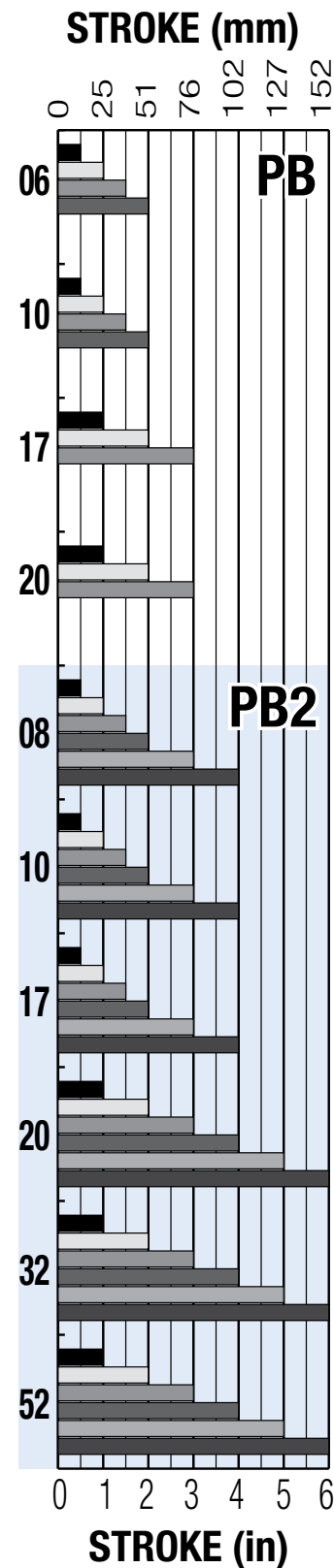

PB Power-Block Rod Cylinder Slide - 06, 10 Sizes

PERFORMANCE

THEORETICAL FORCE vs PRESSURE

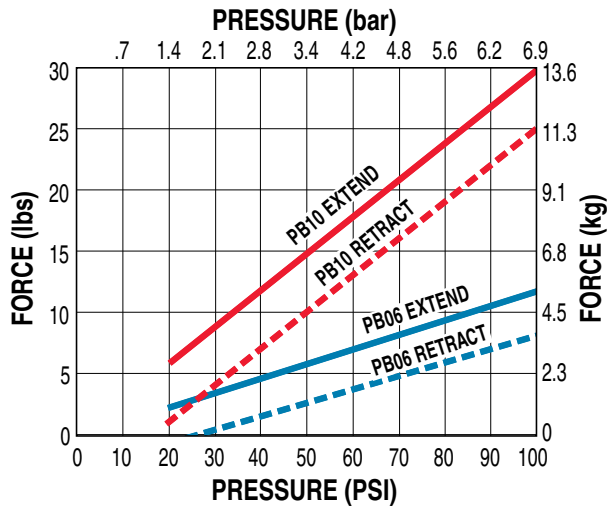

MAX. LOAD WEIGHT vs STROKE LENGTH

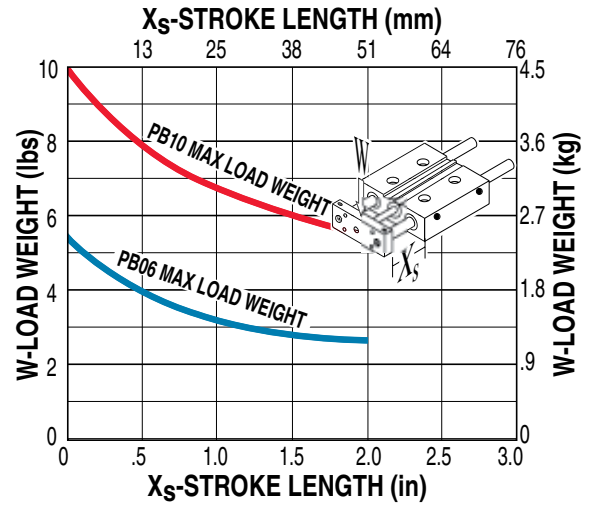

BENDING MOMENTS

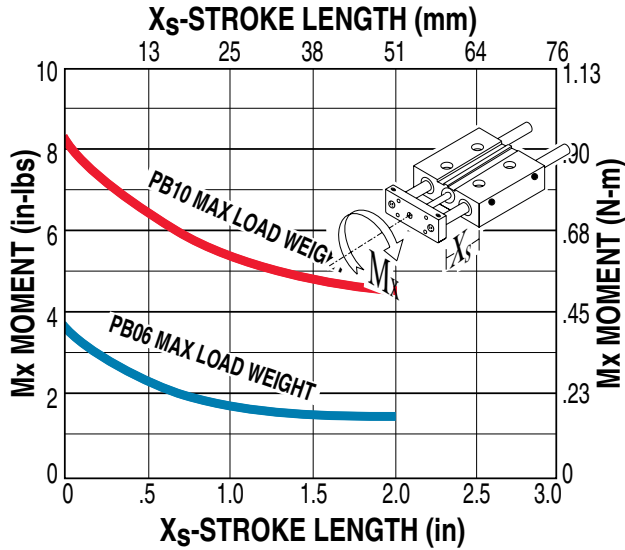

LOAD WEIGHT vs VELOCITY (USING INTERNAL BUMPERS)

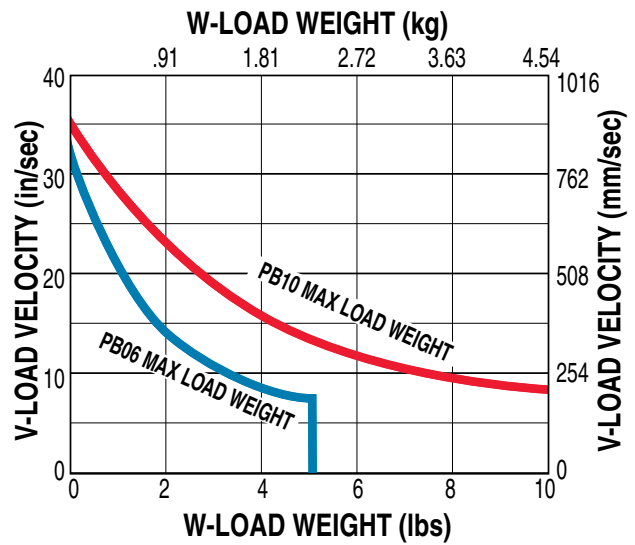

FORCE VS. PRESSURE

Force vs Pressure performance data applies to models with composite bearings.

MAX. LOAD WEIGHT vs STROKE LENGTH

Do not exceed Max. Load curve. Max. Load for composite bearings is based on 200 million linear inches of travel.

BENDING MOMENTS

Max. Moment for composite bearings is based on 200 million linear inches of travel.

LOAD VS VELOCITY

Do not exceed Max. Load curve. Max. Load for Power-Block is based on 200 million linear inches of travel.

PB Power-Block Rod Cylinder Slide - 17, 20 Sizes

PERFORMANCE

THEORETICAL FORCE vs PRESSURE

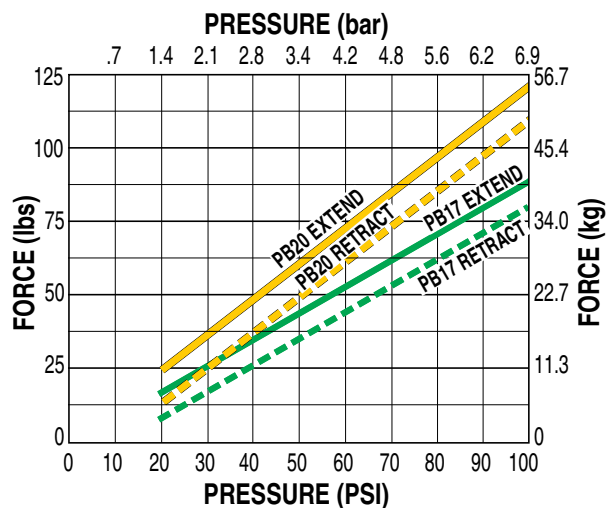

MAX. LOAD WEIGHT vs STROKE LENGTH

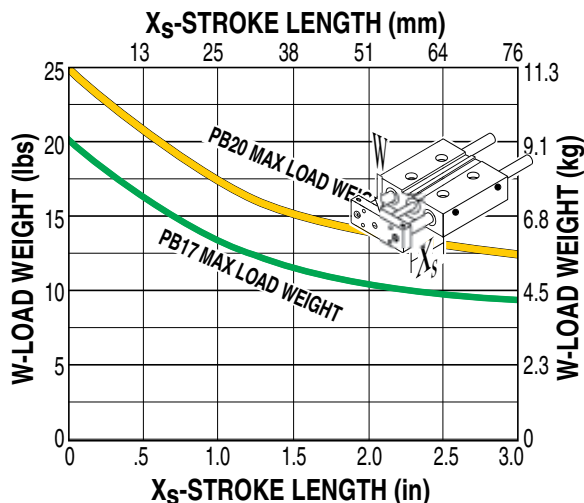

BENDING MOMENTS

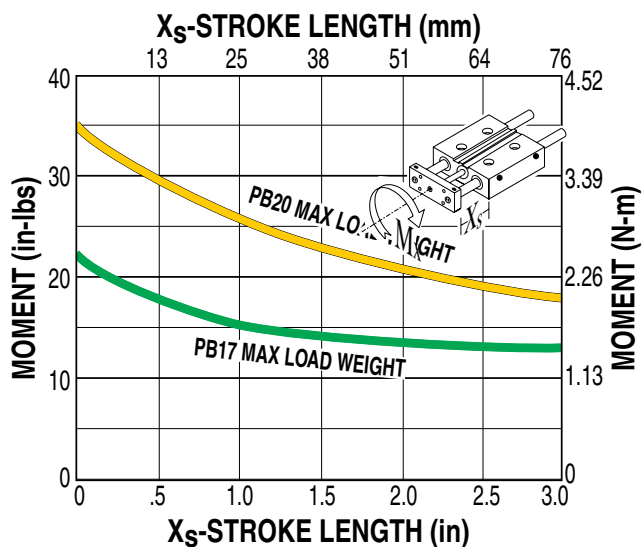

LOAD WEIGHT vs VELOCITY (USING INTERNAL BUMPERS)

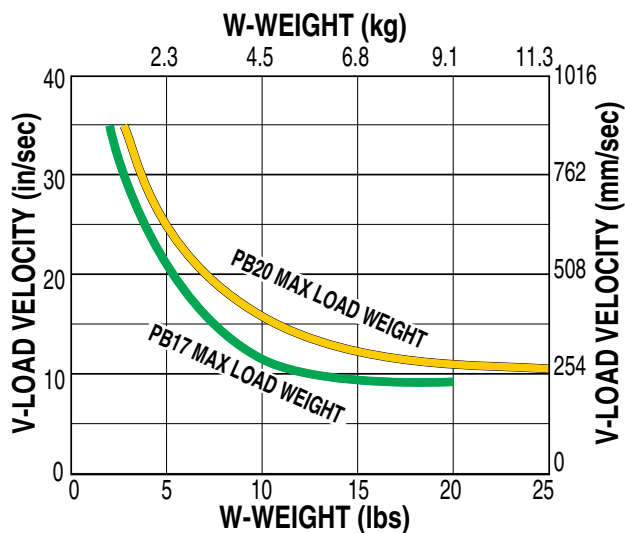

FORCE VS. PRESSURE

Force vs Pressure performance data applies to models with composite bearings.

MAX. LOAD WEIGHT vs STROKE LENGTH

Do not exceed Max. Load curve. Max. Load for composite bearings is based on 200 million linear inches of travel.

BENDING MOMENTS

Max. Moment for composite bearings is based on 200 million linear inches of travel.

LOAD VS VELOCITY

Do not exceed Max. Load curve. Max. Load for Power-Block is based on 200 million linear inches of travel.

PB Power-Block Rod Cylinder Slide - All Sizes

SPECIFICATIONS

	BORE SIZE		WEIGHT				STROKE LENGTH		MAX. PRESSURE		TEMPERATURE RANGE	
			BASE		PER UNIT OF STROKE							
	in	mm	lbs	kg	lbs	kg	in	mm	PSI	bar	°F	°C
06	0.375	9.5	0.26	0.1	0.18	0.08	0.5, 1.0, 1.5, 2.0	13, 25, 38, 51	100	6.895	20 to 140	-7 to 60
10	0.625	16.0	0.53	0.2	0.30	0.14						
17	1.062	27.0	1.08	0.5	0.57	0.26	1.0, 2.0, 3.0	25, 51, 76				
20	1.250	31.8	1.56	0.7	0.88	0.40						

PB



ORDER CODES

PB06, PB10, PB17, PB20
inch (U.S. Standard)

PB OPTIONS	Page
Stop Collar/Bumper	PB_6
Dual Tooling Plate	PB_6
Switches	PB_14
MORE INFORMATION	Page
Application Guidelines	PB_18
Ordering	PB_20
Selection	PB_17

OPTIONS



STOP COLLAR / BUMPER KIT

- Includes 2 stop collars and 1/4" thick polyurethane external bumpers to help absorb impact shock



DUAL TOOLING PLATE

- Added flexibility for many applications



SWITCHES

- Available in Reed, Hall-effect and Triac
- 15ft. cable with flying leads; available with quick-disconnect couplers

DIMENSIONS

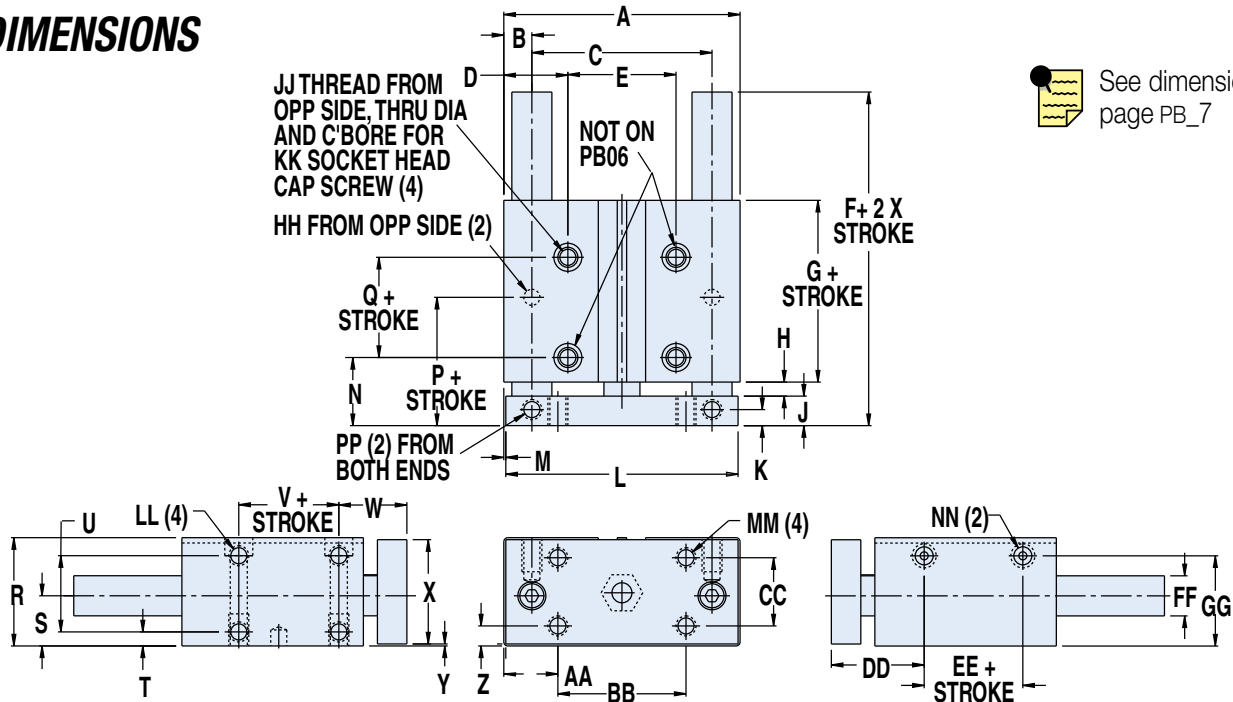

See dimensions page PB_7

PB Power-Block Rod Cylinder Slide - All Sizes



DIMENSIONS



See drawing page PB_6

	PB06		PB10		PB17		PB20	
	in	mm	in	mm	in	mm	in	mm
BORE	0.375	9.5	0.625	16.0	1.013	27.0	1.25	31.8
A	1.688	42.9	2.250	57.2	3.125	79.4	3.688	93.7
B	0.219	5.6	0.297	7.5	0.375	9.5	0.438	11.1
C	1.250	31.8	1.656	42.1	2.375	60.3	2.813	71.5
D	0.500	12.7	0.656	16.7	0.844	21.4	1.000	25.4
E	0.688	17.5	0.938	23.8	1.438	36.5	1.688	42.9
F	2.370	60.2	2.853	72.5	3.070	78.0	3.198	81.2
G	1.375	34.9	1.672	42.5	1.781	45.2	1.833	46.6
H	0.156	4.0	0.219	5.6	0.188	4.8	0.219	5.6
J	0.273	6.9	0.335	8.5	0.460	11.7	0.460	11.7
K	0.125	3.2	0.156	4.0	0.250	6.4	0.250	6.4
L	1.625	41.3	2.188	55.6	3.063	77.8	3.625	92.1
M	0.031	0.8	0.031	0.8	0.031	0.8	0.031	0.8
N	0.688	17.5	0.875	22.2	1.063	27.0	1.063	27.0
P	0.688	17.5	1.063	27.0	0.656	16.7	1.000	25.4
Q	0.500	12.7	0.625	15.9	0.563	14.3	0.563	14.3
R	0.891	22.6	1.063	27.0	1.484	37.7	1.688	42.9
S	0.406	10.3	0.500	12.7	0.609	15.5	0.781	19.8
T	0.125	3.2	0.141	3.6	0.156	4.0	0.219	5.6
U	0.594	15.1	0.750	19.1	1.125	28.6	1.188	30.2
V	0.500	12.7	0.625	15.9	0.563	14.3	0.563	14.3
W	0.688	17.5	0.875	22.2	1.063	27.0	1.063	27.0
X	0.828	21.0	1.000	25.4	1.422	36.1	1.623	41.2
Y	0.031	0.8	0.031	0.8	0.031	0.8	0.031	0.8
Z	0.156	4.0	0.188	4.8	0.219	5.6	0.313	8.0
AA	0.469	11.9	0.500	12.7	0.688	17.5	0.844	21.4
BB	0.750	19.1	1.250	31.8	1.750	44.5	2.000	50.8
CC	0.563	14.3	0.688	17.5	1.000	25.4	1.063	27.0
DD	0.913	23.2	1.281	32.5	1.429	36.3	1.449	36.8
EE	0.466	11.8	0.450	11.4	0.500	12.7	0.540	13.7
FF	0.250	6.4	0.375	9.5	0.500	12.7	0.625	15.9
GG	0.734	18.6	0.875	22.2	1.203	30.6	1.406	35.7
HH*	.1875/.1865 X .22 DP	4.8/4.7 x 5.6 DP	.1875/.1865 X .22 DP	4.8/4.7 x 5.6 DP	.2500/.2490 X .25 DP	6.4/6.3 x 6.4 DP	2500/.2490 X .25 DP	6.4/6.3 x 6.4 DP
JJ	6-32 X .38" (9.5) DP		8-32 X .38" (9.5) DP		1/4-20 X .25" (6.4) DP		5/16-18UNC X .50 (12.7)" DP	
KK	#4		#6		#10		1/4	
LL	6-32 X .25" (6.4) DP		8-32 X .38" (9.5) DP		10-24 X .44" (11.2) DP		5/16-18 X .50" (12.7) DP	
MM	6-32 THRU		8-32 THRU		10-24 THRU		5/16-18 THRU	
NN	10-32 UNF		10-32 UNF		1/8-27 NPT		1/8-27 NPT	
PP	6-32UNC X .22" (5.6) DP		8-32UNC X .28" (7.1) DP		10-24UNC X .34" (8.6) DP		5/16-18UNC X .38" (9.7) DP	

*Dowel Pins

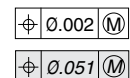

ABT

IXP

BCZ

BC3

BC4

LS

MG

CC

PB

ENGR

PB & PB2 Rod Cylinder Slides - All Sizes

APPLICATIONS

Material Handling

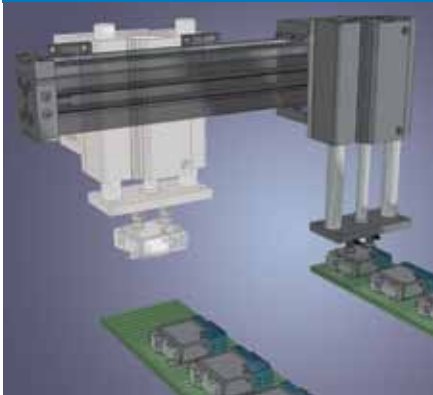

A pick and place application for moving product between conveyors.

Customer Challenge:

A manufacturer of consumer electronic equipment needed a method to move finished product from one conveyor to another quickly without damage or waste.

Application Requirements:

- Fast response, throughput of 20 products per minute
- Consistent positioning
- End-of-stroke adjustment to accommodate varying product lines

Tolomatic Solution:

This side mounted BC3D Band Cylinder with dual 180° option provides the motion along the X axis and support for the PB2 rod cylinder slide which provides the Y axis motion. In this application dual vacuum cups are used, however they are often replaced with a gripper unit with custom tooled fingers for product that does not present a smooth flat surface.

Result:

This continuing customer is pleased with the durability, price and delivery that the BC3 and PB2 actuators manufactured by Tolomatic provide.

Material Handling

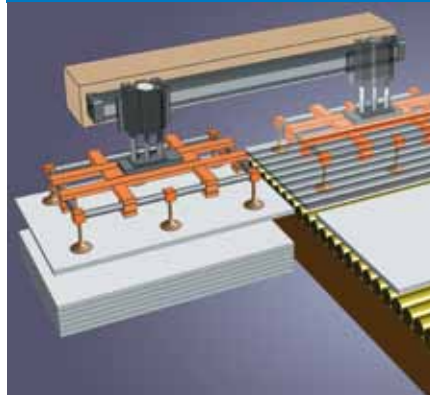

Vacuumized sheet transfer application.

Customer Challenge:

A manufacturer of battery chargers needed a method of taking sheet metal off of pallets and placing onto the assembly line. Speed is critical and end-of-stroke position must be consistent, thus, Tolomatic pneumatic products were chosen for this system.

Application Requirements:

- Fast response, 1 part must be reoriented and moved each 3 seconds
- Movement from end-of-stroke to end-of-stroke with consistent positioning
- Low cost
- End-of-stroke adjustment

Tolomatic Solution:

This application uses a Tolomatic PB2 Rod Cylinder Slide, attached to a BC3 Band Cylinder with adjustable shocks. This actuator assembly moves the vacuum grid attachment that holds the sheet metal.

Result:

The BC3 and PB2 has long-lasting durability for reliable performance at the required speed. This continuing customer is pleased with the price and delivery that Tolomatic provides.

PB2 POWER-BLOCK 2

ENDURANCE TECHNOLOGYSM

Endurance Technology features are designed for maximum durability to provide extended service life.

The Power Block 2 rod cylinder slide features two precision steel guide rods with linear ball or composite bearings to provide positive support of the load. The Power Block 2 withstands heavy side loads making it a great choice for conveyor line stops and load lifting applications. Built-to-order in stroke lengths up to 6 inches.

HIGH PRESSURE CAPABLE

- Designed for pressures up to 150 PSI (10.3 bar) with a 10,000,000 cycle rating

INTERNAL BUMPERS

- Made of urethane composite to prolong cylinder life and reduce noise



PISTON MAGNET

- Piston magnet is a standard feature allowing sensor mounting whenever required

LARGE SHAFTS

- Shafts up to 1.25" diameter

DURABLE DESIGN

- Tough, lightweight extruded aluminum in a low profile package

DURABLE BEARING OPTIONS

LINEAR BALL BEARINGS

- Low friction, long life
- Best tooling plate accuracy



COMPOSITE BEARINGS

- Thin profile allows use of oversize guide rods
- Best choice for impact use or high contaminant environments

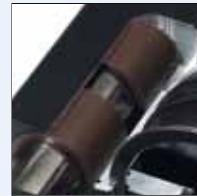

PLATED STEEL TOOLING PLATE

- Threaded bolt thru holes for tooling plate mounting

MOUNTING FLEXIBILITY

- T-slots and threaded holes for base mounting



OPTIONS



SWITCHES

- Available in Reed, Hall-effect and Triac
- 15ft. cable with flying leads; available with quick-disconnect couplers



ABT
MXP
BCZ
BC3
BC4
LS
MG
CC
PB
ENGR

PB2 Power-Block2 Rod Cylinder Slide - 08, 10, 17 Sizes

PERFORMANCE

THEORETICAL FORCE vs PRESSURE

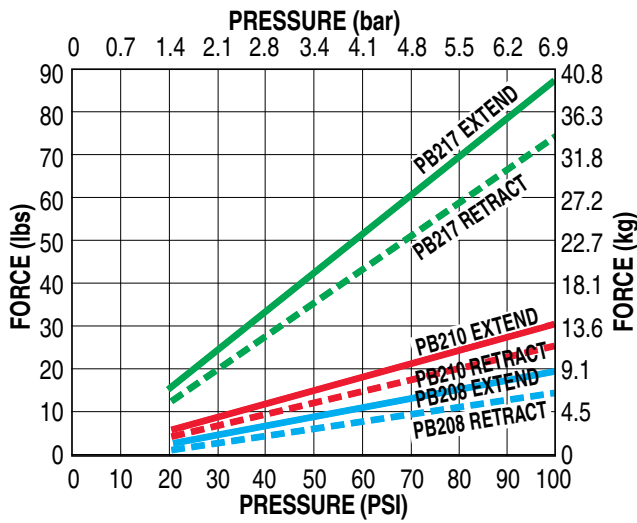

MAX. LOAD WEIGHT vs STROKE LENGTH

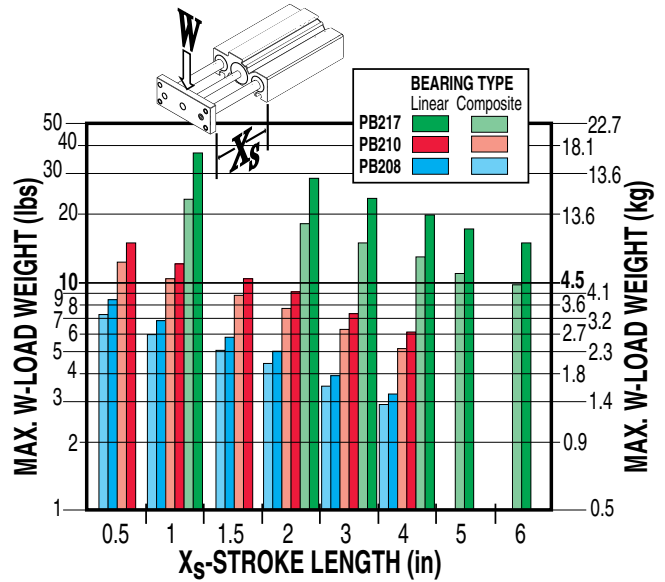

BENDING MOMENTS

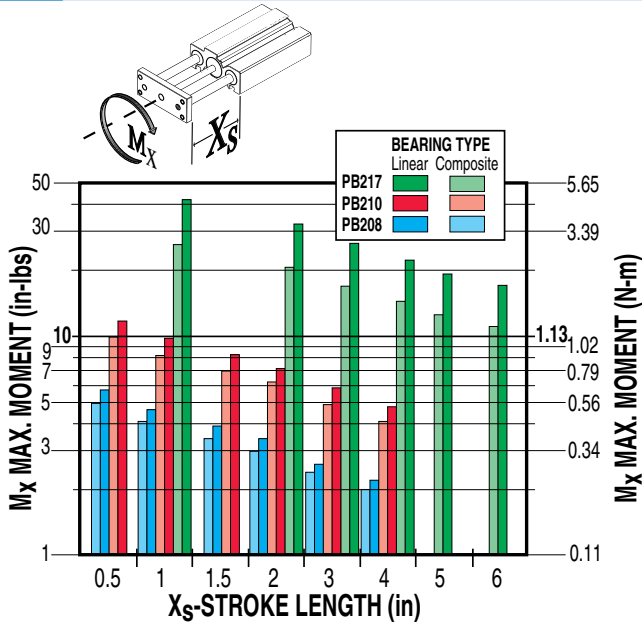

LOAD WEIGHT vs VELOCITY (USING INTERNAL BUMPERS)

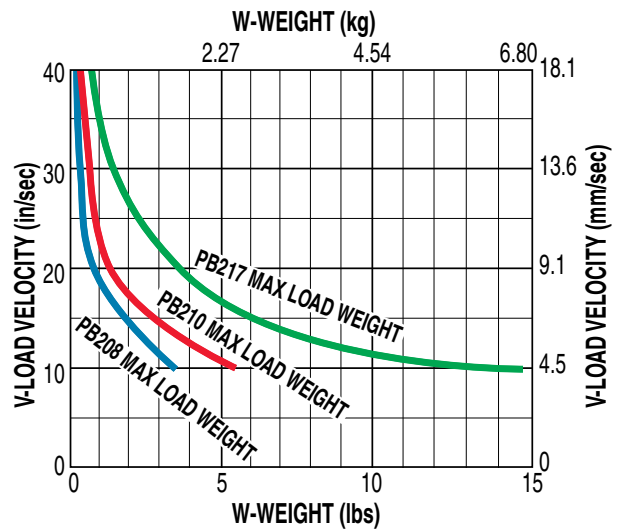

FORCE VS. PRESSURE

Force vs Pressure performance data applies to models with composite bearings.

MAX. LOAD WEIGHT vs STROKE LENGTH

Do not exceed Max. Load curve. Max. Load for composite bearings is based on 200 million linear inches of travel.

BENDING MOMENTS

Max. Moment for composite bearings is based on 200 million linear inches of travel.

LOAD VS VELOCITY

Do not exceed Max. Load curve. Max. Load for Power-Block is based on 200 million linear inches of travel.

PB2 Power-Block2 Rod Cylinder Slide - 20, 32, 52 Sizes

PERFORMANCE

THEORETICAL FORCE vs PRESSURE

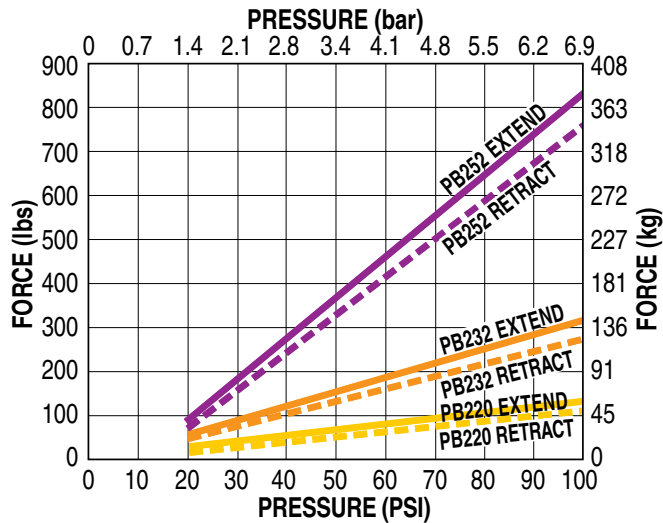

MAX. LOAD WEIGHT vs STROKE LENGTH

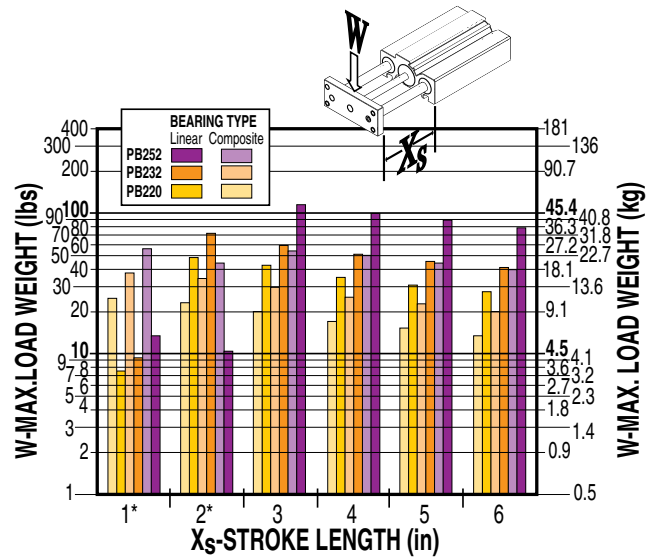

*PB220, PB232 and PB252 - 1" Stroke and PB252 - 2" Stroke are units with one set of bearings.

BENDING MOMENTS

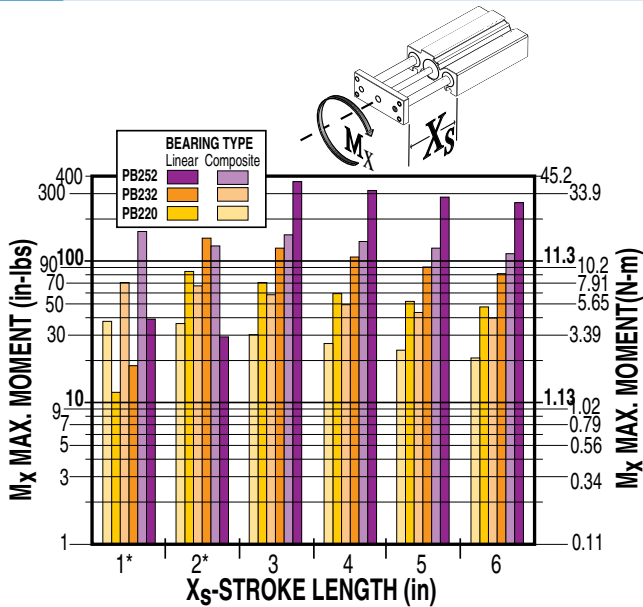

*PB220, PB232 and PB252 - 1" Stroke and PB252 - 2" Stroke are units with one set of bearings.

LOAD WEIGHT vs VELOCITY (USING INTERNAL BUMPERS)



FORCE VS. PRESSURE

Force vs Pressure performance data applies to models with composite bearings.

MAX. LOAD WEIGHT vs STROKE LENGTH

Do not exceed Max. Load curve. Max. Load for composite bearings is based on 200 million linear inches of travel.

BENDING MOMENTS

Max. Moment for composite bearings is based on 200 million linear inches of travel.

LOAD VS VELOCITY

Do not exceed Max. Load curve. Max. Load for Power-Block is based on 200 million linear inches of travel.

PB2 Power-Block2 Rod Cylinder Slide - All Sizes

SPECIFICATIONS

LB = Linear Bearing CB = Composite Bearing

SIZE		08		10		17		20		32		52		
BEARING		LB	CB	LB	CB	LB	CB	LB	CB	LB	CB	LB	CB	
BORE SIZE	in	0.50		0.63		1.06		1.25		2.00		3.25		
	mm	12.7		15.9		27.0		31.8		50.8		82.6		
STROKE & WEIGHT	0.5" (13mm)	lbs	0.62	0.65	0.86	0.90	NA							
		kg	0.28	0.29	0.39	0.41	NA							
	1.0" (25mm)	lbs	0.70	0.75	0.97	1.03	1.97	2.32	2.79	3.32	4.85	5.59	10.92	11.74
		kg	0.32	0.34	0.44	0.47	0.89	1.05	1.27	1.51	2.20	2.54	4.95	5.33
	1.5" (38mm)	lbs	0.78	0.85	1.08	1.17	NA							
		kg	0.35	0.39	0.49	0.53	NA							
	2.0" (51mm)	lbs	0.86	0.95	1.19	1.30	2.38	2.88	3.87	4.36	6.43	6.95	12.57	13.63
		kg	0.39	0.43	0.54	0.59	1.08	1.31	1.76	1.98	2.92	3.15	5.70	6.18
	3.0" (76mm)	lbs	1.03	1.16	1.42	1.57	2.80	3.43	4.49	5.14	5.48	8.03	15.71	16.57
		kg	0.47	0.53	0.64	0.71	1.27	1.56	2.04	2.33	2.49	3.64	7.13	7.52
	4.0" (102mm)	lbs	1.20	1.35	1.64	1.84	3.21	3.40	5.11	5.92	8.20	9.12	17.36	18.46
		kg	0.54	0.61	0.74	0.83	1.46	1.54	2.32	2.69	3.72	4.14	7.87	8.37
	5.0" (127mm)	lbs	NA				3.63	4.54	5.72	6.71	9.08	10.20	19.00	20.36
		kg	NA				1.65	2.06	2.59	3.04	4.12	4.63	8.62	9.24
6.0" (152mm)	lbs	NA				4.04	5.09	6.34	7.49	9.97	11.28	20.64	22.25	
	kg	NA				1.83	2.31	2.88	3.40	4.52	5.12	9.36	10.09	
STROKE LENGTH	in	0.5, 1.0, 1.5, 2.0, 3.0, 4.0						1.0, 2.0, 3.0, 4.0, 5.0, 6.0						
	mm	13, 25, 38, 51, 76, 102						25, 51, 76, 102, 127, 152						
MAX. PRESSURE	PSI	100												
	bar	6.895												
TEMP. RANGE	°F	20 to 140												
	°C	-7 to 60												

IMPACT LOADING

(Composite Bearings ONLY)

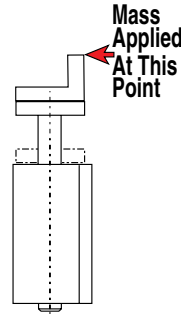

$$KE = \frac{1}{2} W \frac{v^2}{g}$$

KE = Energy

w = Weight in Lbs.

g = 32.2 Ft./sec.²
(gravitational constant)

v = Ft./sec. (velocity)

In applications such as conveyor stops impact loading may be a factor. The table below gives the maximum KE energy for each of the PB2 models. Use the above equation to determine the KE for your application. Your result should not exceed the maximum KE for the PB2 model you select.

	BORE SIZE		MAX. "KE"	
	in	mm	in-lbs	N-m
08	0.500	12.7	1.08	0.12
10	0.625	15.9	5.64	0.64
17	1.063	27.0	17.88	2.02
20	1.250	31.8	40.80	4.61
32	2.000	50.8	129.60	14.64
52	3.250	82.6	285.60	32.27

DIMENSIONS

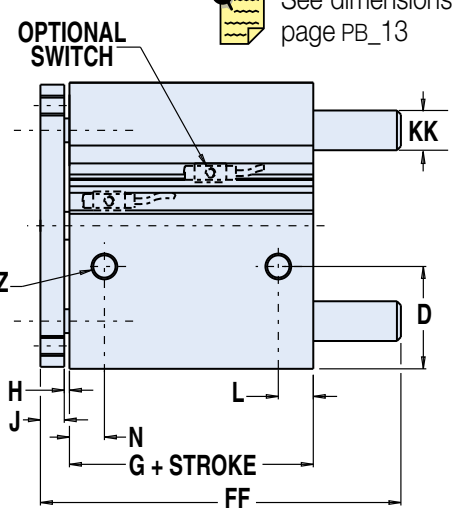
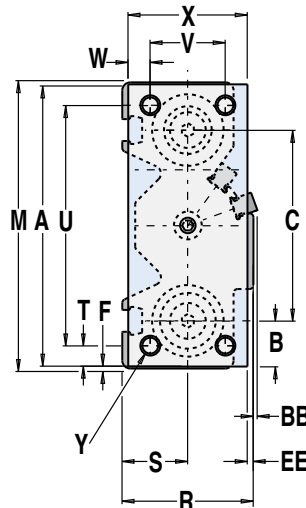
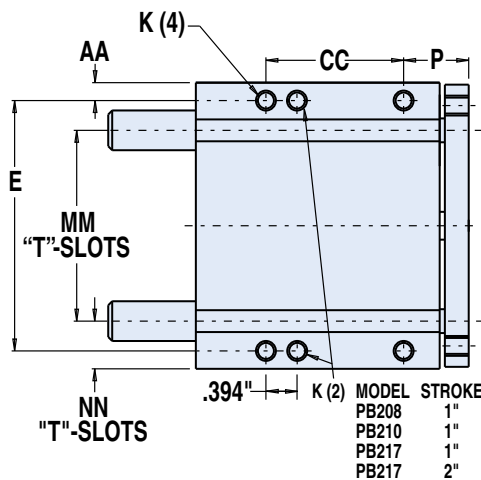

See dimensions page PB_13

JJ TAPPED HOLE THRU CENTERED ON HH

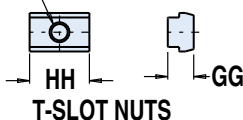

PB2 Power-Block2 Rod Cylinder Slide - All Sizes

DIMENSIONS



See drawing
page PB_12

ABT
MXP
BCZ
BC3
BC4
LS
MG
CC
PB
ENGR

Size	08		10		17		20		32		52		
Bore	0.500 (12.7)		0.625 (15.9)		1.125 (27.0)		1.250 (31.8)		2.000 (50.8)		3.250 (82.6)		
A	2.190	55.6	2.380	60.5	3.380	85.9	4.440	112.8	5.440	138.2	7.280	184.9	
B	0.33	8.4	0.39	9.9	0.55	14.0	0.72	18.3	0.81	20.6	0.89	22.6	
C	1.53	38.9	1.59	40.5	2.28	57.9	3.00	76.2	3.81	96.9	5.50	139.7	
D	1.120	28.4	1.220	31.0	1.200	30.5	1.610	40.9	1.670	42.4	2.110	53.6	
E	1.969	50.0	2.126	54.0	2.992	76.0	3.937	100.0	4.882	124.0	6.535	166.0	
F	0.031	0.8	0.031	0.8	0.047	1.2	0.031	0.8	0.031	0.8	0.047	1.2	
G	1.738	44.1	1.795	45.6	1.881	47.8	1.834	46.6	2.297	58.3	2.693	68.4	
H	0.063	1.6	0.063	1.6	0.063	1.6	0.082	2.1	0.063	1.6	0.063	1.6	
J	0.38	9.7	0.38	9.7	0.38	9.7	0.38	9.7	0.50	12.7	0.63	16.0	
K	#8-32x.34DP (4)		#10-24x.38DP (4)		1/4-20x.44 DP (4)		5/16-18 x .44 DP (4)		3/8-16 x .56 DP (4)		1/2-13 x .75 DP (4)		
L	0.60	15.2	0.55	14.0	0.52	13.2	0.53	13.5	0.58	14.7	0.69	17.5	
M	2.25	57.2	2.44	62.0	3.47	88.1	4.50	114.3	5.50	139.7	7.37	187.2	
N	0.47	11.9	0.50	12.7	0.52	13.2	0.53	13.5	0.58	14.7	0.69	17.5	
P	0.87	22.0	0.91	23.0	0.95	24.0	1.02	26.0	1.14	29.0	1.54	39.0	
R	1.11	28.2	1.33	33.8	1.72	43.7	2.06	52.3	2.48	63.0	3.77	95.8	
S	0.52	13.2	0.67	17.0	0.83	21.1	1.03	26.2	1.23	31.2	1.89	48.0	
T	0.15	3.8	0.16	4.1	0.31	7.9	0.33	8.4	0.36	9.1	0.49	12.4	
U	1.890	48.01	2.047	51.99	2.756	70.00	3.780	96.01	4.724	119.99	6.299	159.99	
V	0.551	14.00	0.630	16.00	1.024	26.01	1.181	30.00	1.575	40.01	2.362	59.99	
W	0.16	4.1	0.19	4.8	0.24	6.1	0.35	8.9	0.37	9.4	0.57	14.5	
X	0.88	22.4	1.00	25.4	1.50	38.1	1.88	47.8	2.38	60.5	3.50	88.9	
Y	#8-32 Thru (4)		#10-24 Thru (4)		1/4-20 Thru (4)		5/16-18 Thru (4)		3/8-16 Thru (4)		1/2-13 Thru (4)		
Z	10-32UNF (2)		10-32UNF (2)		1/8 NPT (2)		1/8-27 NPT (2)		1/4-18 NPT (2)		3/8-18 NPT (2)		
AA	0.14	3.6	0.16	4.1	0.24	6.1	0.28	7.1	0.31	7.9	0.42	10.7	
BB	0.05	1.3	0.08	2.0	0.18	4.6	0.06	1.5	-	-	-	-	
CC - STROKE LENGTH	0.5	0.591	15.01	0.669	16.99	NA							
	1.0	1.378	35.00	1.457	37.01	1.575	40.01	1.181	30.00	1.378	35.00	1.575	40.01
	1.5	1.772	45.01	1.850	46.99	NA							
	2.0	2.165	54.99	2.244	57.00	2.362	59.99	2.165	54.99	2.362	59.99	2.559	65.00
	3.0	3.150	80.01	3.228	81.99	3.346	84.99	3.150	80.01	3.346	84.99	3.543	89.99
	4.0	4.134	105.00	4.213	107.01	4.331	110.01	4.134	105.00	4.331	110.01	4.528	115.01
	5.0	NA				5.315	135.00	5.118	130.00	5.315	135.00	5.512	140.00
	6.0	NA				6.299	159.99	6.102	154.99	6.299	159.99	6.496	165.00
EE	0.08	2.0	0.17	4.3	0.08	2.0	0.09	2.3	0.03	0.8	0.12	3.0	
FF - Linear Bearing / Stroke Length	0.5	2.67	67.8	2.86	72.6	NA							
	1.0	3.17	80.5	3.36	85.3	4.14	105.2	3.17	80.5	3.43	87.1	4.19	106.4
	1.5	3.67	93.2	3.86	98.0	NA							
	2.0	4.17	105.9	4.36	110.7	5.14	130.6	5.67	144.0	6.06	153.9	5.19	131.8
	3.0	5.17	131.3	5.36	136.1	6.14	156.0	6.67	169.4	7.06	179.3	8.44	214.4
	4.0	6.17	156.7	6.36	161.5	7.14	181.4	7.67	194.8	8.06	204.7	9.44	239.8
	5.0	NA				8.14	206.8	8.67	220.2	9.06	230.1	10.44	265.2
6.0	NA				9.14	232.2	9.67	245.6	10.06	255.5	11.44	290.6	
FF - Composite Bearing / Stroke Length	0.5	2.67	67.8	2.86	72.6	NA							
	1.0	3.17	80.5	3.36	85.3	4.14	105.2	3.92	99.6	4.43	112.5	4.94	125.5
	1.5	3.67	93.2	3.86	98.0	NA							
	2.0	4.17	105.9	4.36	110.7	5.14	130.6	5.67	144.0	6.06	153.9	5.94	150.9
	3.0	5.17	131.3	5.36	136.1	6.14	156.0	6.67	169.4	7.06	179.3	8.44	214.4
	4.0	6.17	156.7	6.36	161.5	7.14	181.4	7.67	194.8	8.06	204.7	9.44	239.8
	5.0	NA				8.14	206.8	8.67	220.2	9.06	230.1	10.44	265.2
6.0	NA				9.14	232.2	9.67	245.6	10.06	255.5	11.44	290.6	
GG	0.22	5.6	0.22	5.6	0.25	6.4	0.25	6.4	0.41	10.4	0.41	10.4	
HH	0.66	16.8	0.66	16.8	0.75	19.1	0.75	19.1	0.94	23.9	0.94	23.9	
JJ	10-24		10-24		1/4-20		1/4-20		5/16-18		5/16-18		
KK - Shaft Ø	LB	0.250	6.35	0.375	9.53	0.500	12.70	0.625	15.88	0.750	19.05	1.000	25.40
	CB	0.375	9.53	0.500	12.70	0.750	19.05	0.875	22.23	1.000	25.40	1.250	31.75
MM	0.781	19.8	1.438	36.5	2.125	54.0	3.000	76.2	3.625	92.1	5.188	131.8	
NN	0.73	18.5	0.50	12.7	0.67	17.0	0.75	19.1	0.94	23.9	1.09	27.7	

LB = Linear Bearing
CB = Composite Bearing

PB & PB2 Switches - All Sizes

SWITCHES



There are 10 sensing choices: DC reed, form A (open) or form C (open or closed); AC reed (Triac, open); Hall-effect, sourcing, PNP (open); Hall-effect, sinking, NPN (open); each with either flying leads or QD (quick disconnect). Commonly used to send analog signals to PLC (programmable logic controllers), TLL, CMOS circuit or other controller device. These switches are activated by the actuator's magnet.

Switches contain reverse polarity protection. QD cables are shielded; shield should be terminated at flying lead end.

If necessary to remove factory installed switches, be sure to reinstall on the same of side of actuator with scored face of switch toward internal magnet.

SPECIFICATIONS

ORDER CODE	REED DC				REED AC		HALL-EFFECT DC			
	RT	RM	BT	BM	CT	CM	TT	TM	KT	KM
PART NUMBER	3600-9082	3600-9083	3600-9084	3600-9085	3600-9086	3600-9087	3600-9088	3600-9089	3600-9090	3600-9091
LEAD	5m	QD*	5m	QD*	5m	QD*	5m	QD*	5m	QD*
CABLE SHIELDING	Unshielded	Shielded†	Unshielded	Shielded†	Unshielded	Shielded†	Unshielded	Shielded†	Unshielded	Shielded†
SWITCHING LOGIC	"A" Normally Open		"C" Normally Open or Closed		Triac Normally Open		PNP (Sourcing) Normally Open		NPN (Sinking) Normally Open	
MECHANICAL CONTACTS	Single-Pole Single-Throw		Single-Pole Double-Throw		Single-Pole Single-Throw		NO, These Are Solid State Components			
COIL DIRECT	Yes		Yes		Yes		—			
POWER LED	None		None		None		None		None	
SIGNAL LED	Red		None		None		Red		Red	
OPERATING VOLTAGE	200 Vdc max.		120 Vdc max.		120 Vac max.		5 - 25 Vdc			
OUTPUT RATING	—		—		—		25 Vdc, 200mA dc			
OPERATING TIME	0.6 msec max. (including bounce)		0.7 msec max. (including bounce)		—		< 10 micro sec.			
OPERATING TEMPERATURE	-40°F [-40°C] to 158°F [70°C]						0°F [-18°C] to 150°F [66°C]			
RELEASE TIME	1.0 msec. max.		—		—		—			
ON TRIP POINT	—		—		—		150 Gauss maximum			
OFF TRIP POINT	—		—		—		40 Gauss minimum			
**POWER RATING (WATTS)	10.0 §		3.0 §§		10.0		5.0			
VOLTAGE DROP	2.6 V typical at 100 mA		NA		—		—			
RESISTANCE	0.1 Ω Initial (Max.)		—		—		—			
CURRENT CONSUMPTION	—		—		1 Amp at 86°F [30°C] 0.5 Amp at 140°F [60°C]		200 mA at 25 Vdc			
FREQUENCY	—		—		47 - 63 Hz		—			
CABLE MIN. BEND RADIUS	STATIC		0.630" [16mm]							
	DYNAMIC		Not Recommended							

CAUTION: DO NOT OVER TIGHTEN SWITCH HARDWARE WHEN INSTALLING!

**** WARNING:** Do not exceed power rating (Watt = Voltage X Amperage). Permanent damage to sensor will occur.

*QD = Quick Disconnect; Male coupler is located 6" [152mm] from sensor, Female coupler to flying lead (part #2503-1025) distance is 197" [5m] also see Cable Shielding specification above

REPLACEMENT OF QD SWITCHES MANUFACTURED BEFORE JULY 1, 1997: It will be necessary to replace or rewire the female end coupler.



Reed Switch Life Expectancy: Up to 200,000,000 cycles (depending on load current, duty cycle and environmental conditions)

†Shielded from the female quick disconnect coupler to the flying leads. Shield should be terminated at flying lead end.

§ Maximum current 500mA (not to exceed 10VA) Refer to Temperature vs. Current graph and Voltage Derating graph

§§ Maximum current 250mA (not to exceed 3VA) Refer to Temperature vs. Current graph and Voltage Derating graph

PB & PB2 Switches - All Sizes

PERFORMANCE

TEMP. vs CURRENT, DC REED

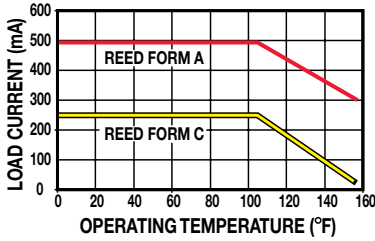

TEMP. vs CURRENT, AC REED

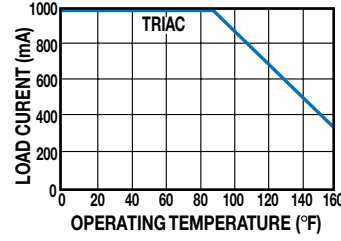

VOLTAGE DERATING, DC REED

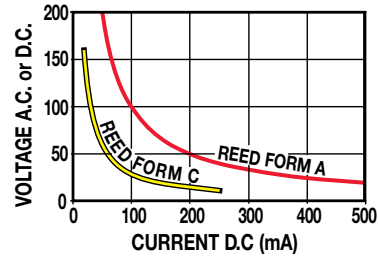

WIRING DIAGRAMS

RT & **R**M DC REED, FORM A

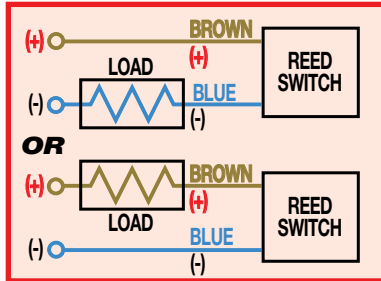

CT & **C**M AC REED, TRIAC

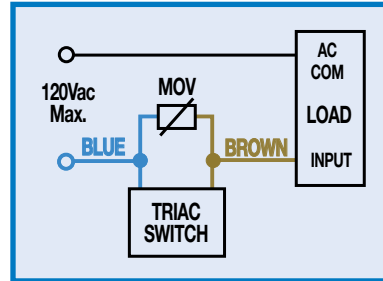

BT & **B**M DC REED, FORM C

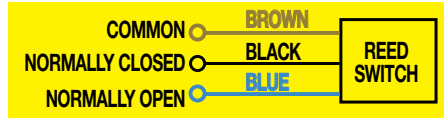

TT & **T**M HALL-EFFECT, SOURCING, PNP

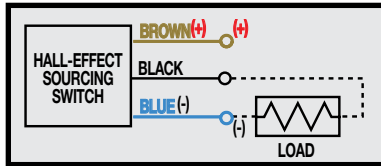

KT & **K**M HALL-EFFECT, SINKING, NPN

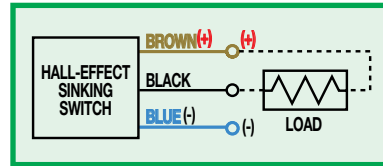

INSTALLATION INFORMATION



! THE NOTCHED FACE OF THE SWITCH INDICATES THE SENSING SURFACE AND MUST FACE TOWARD THE MAGNET.

DIMENSIONS

PB208, PB210

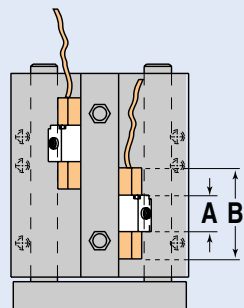

PB217, PB220
PB232, PB252

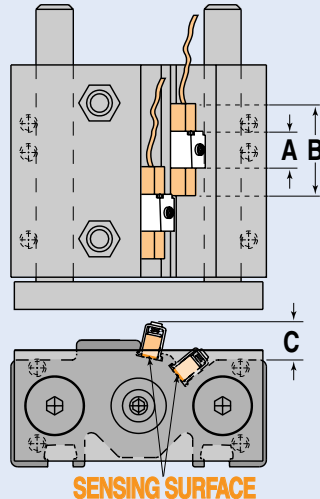

MODEL	BORE	A	B	C
PB208	0.500	0.50	1.25	0.25
PB210	0.625	0.50	1.25	0.26
PB217	1.063	0.50	1.25	0.52
PB220	1.250	0.50	1.25	0.48
PB232	2.000	0.50	1.25	0.64
PB252	3.000	0.50	1.25	0.85

Dimensions in inches

MODEL	BORE	A	B	C
PB208	12.70	12.70	31.75	6.35
PB210	15.88	12.70	31.75	6.60
PB217	27.00	12.70	31.75	13.21
PB220	31.75	12.70	31.75	12.19
PB232	50.80	12.70	31.75	16.26
PB252	76.20	12.70	31.75	21.59

Dimensions in millimeters

Application Data Worksheet

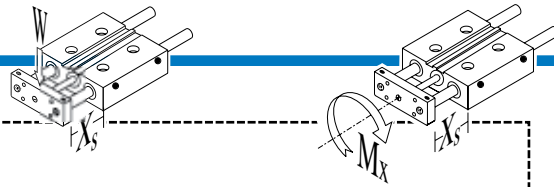

ABT
MXP
BC2
BC3
BC4
LS
MG
CC
PB
ENGR

STROKE LENGTH _____
 inch (S I K) millimeters
 (U.S. Standard) (Metric)

AVAILABLE AIR PRESSURE _____
 PSI bar
 (U.S. Standard) (Metric)

REQUIRED THRUST FORCE _____
 lbf N
 (U.S. Standard) (Metric)

LOAD _____
 lb kg
 (U.S. Standard) (Metric)

LOAD CENTER OF GRAVITY DISTANCE TO TOOLING PLATE CENTER
 d_x _____
 d_y _____
 d_z _____
 inch (U.S. Standard) millimeters (Metric)

FORCES APPLIED TO TOOLING PLATE W _____
 lbf N
 (U.S. Standard) (Metric)

BENDING MOMENTS APPLIED TO TOOLING PLATE M_x _____
 in-lbs N-m
 (U.S. Standard) (Metric)

FINAL VELOCITY _____
 in/sec mm/sec
 (U.S. Standard) (Metric)

MOVE TIME sec. _____

NO. OF CYCLES _____
 per minute per hour

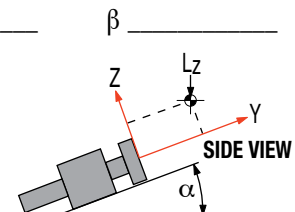
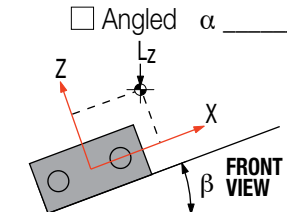
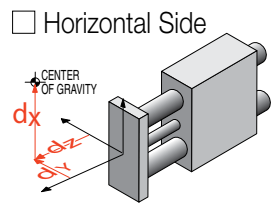
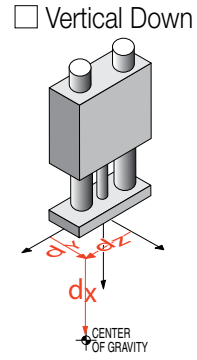
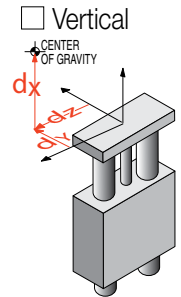
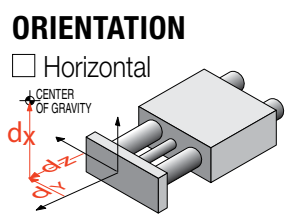

OTHER ISSUES: _____
 (i.e. Environment, _____
 Temperature, _____
 Contamination, etc.) _____

Contact information: _____



Fax (1-763-478-8080) or call Tolomatic (1-800-328-2174) with the above information. We will provide any assistance needed to determine the proper actuator.

Rod Cylinder Slide Selection Guidelines - PB & PB2 - All Sizes

PROVIDING LOAD GUIDANCE AND SUPPORT

The process of selecting a load bearing actuator for a given application can be complex. **It is highly recommended that you contact Tolomatic or a Tolomatic Distributor for assistance in selecting the best actuator for your application.** The following overview of the selection guidelines are for educational purposes only.

1 COMPILE APPLICATION REQUIREMENTS

To determine the appropriate Tolomatic rod cylinder slide for an application, compile the following information:

- Available pressure (PSI)
- Weight of load (lbs. or kgs.)
- Orientation of load (lbs. or kgs.)
- Velocity of load (in./sec. or mm/sec.)
- Stroke length (in. or mm)

Use the Application Data Worksheet on page PB_16

2 SELECT ROD CYLINDER SLIDE SIZE

- Consult the Theoretical Force vs. Pressure graphs

NOTE: Graphs for PB are on pages PB_4 to 5 and PB2 are on pages PB_10 to 11.

- Cross-reference the load force (or load weight if force is not known) and the available operating pressure. If the intersection falls below the diagonal line, and if moments do not exceed maximum values listed for that model (see Step 4) the Tolomatic rod cylinder slide will accommodate the application. If the intersection is above the diagonal line, a

larger rod cylinder slide bore size should be considered.

NOTE: Additional force may be required to obtain the necessary acceleration for vertical or horizontal loads.

3 DETERMINE EFFECT OF LOAD VS. EXTENDED LENGTH

- Consult the Max. Load Weight vs Stroke Length Chart for the Tolomatic rod cylinder slides.
- Cross-reference the load weight and the extended length. If the intersection falls below the maximum load line, and if moments do not exceed maximum values listed for that model (see Step 4), the rod cylinder slide will accommodate the application. If the intersection is above the diagonal line, a larger rod cylinder slide bore size should be considered.

4 DETERMINE NATURE OF LOAD AND THE EFFECT OF BENDING MOMENTS

If the rod cylinder slide will guide and support a load located directly on center of the tooling plate, bending moments will not be a factor in the rod cylinder slide selection.

NOTE: the maximum load weight "W" must not exceed the capacity limits of the rod cylinder slide selected.

- Bending Moments

For off center or side loads, determine the distance from the center of mass of the load to the center of the tooling plate. This measurement is needed to calculate the torque for bending moments.

Should the resulting maximum bending moment exceed figures indicated on the chart, a larger rod cylinder slide should be considered.

5 DETERMINE INTERNAL BUMPER CAPACITY [POWER-BLOCK2 ONLY]

- Consult the Load vs Velocity Data Chart for the Power-Block model selected. The velocities listed on the charts are final or bumper impact velocities.
- Cross-reference the final velocity and weight of the load. If the intersection is below the diagonal lines, the internal bumpers on the Power-Block2 may be used. If the point falls above the dashed diagonal line or if the velocity is not known, select a larger rod cylinder slide. On high-cyclic applications, use of external stops is strongly recommended.

6 CONSIDER OPTIONS

- Switches— dc Reed, Hall-effect, or ac Triac - (All Models)
- Bumpers and Stop Collars - (Power-Block)
- Dual Tooling Plate (Power-Block)

ABT

IMXP

BCZ

BC3

BC4

LS

IMG

CC

PB

ENGR

Application Guidelines

The following conditional statements are intended as general guidelines for use of Tolomatic actuators. Since all applications have their own specific operating requirements, consult Tolomatic, Inc. or your local Tolomatic distributor if an application is unconventional or if questions arise regarding the selection process.

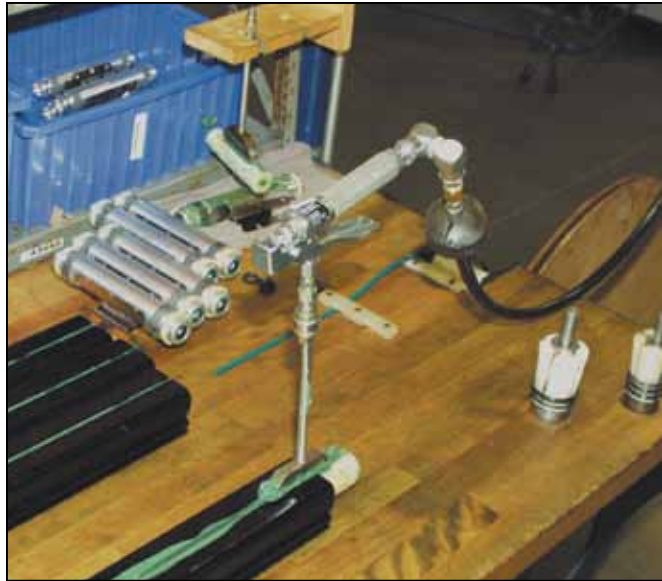

LUBRICATION GUIDELINES

All Tolomatic actuators (except Cable Cylinders) are prelubricated at the factory. To ensure maximum actuator life, the following guidelines should be followed.

• Filtration

We recommend the use of dry, filtered air in our products. "Filtered air" means a level of 10 Micron or less. "Dry" means air should be free of appreciable amounts of moisture. Regular maintenance of installed

filters will generally keep excess moisture in check.

• External Lubricators (optional)

The factory prelubrication of Tolomatic actuators will provide optimal performance without the use of external lubrication. However, external lubricators can further extend service life of pneumatic actuators if the supply is kept constant.

Oil lubricators, (mist or drop) should supply a minimum of 1 drop per 20 standard cubic feet per minute to the

cylinder. As a rule of thumb, double that rate if water in the system is suspected. Demanding conditions may require more lubricant.

If lubricators are used, we recommend a non-detergent, 20cP @ 140°F 10-weight lubricant. Optimum conditions for standard cylinder operation are +32° to +150°F (+0° to 65.5°C).

NOTE: Use of external lubricators may wash away the factory installed lubrication. External lubricants must be maintained in a constant supply or the results will be a dry actuator prone to premature wear.

• Sanitary Environments

Oil mist lubricators must dispense "Food Grade" lubricants to the air supply. Use fluids with ORAL LD50 toxicity ratings of 35 or higher such as Multitherm® PG-1 or equivalent. Demanding conditions can require a review of the application.

FINAL VELOCITY CALCULATION

Velocity calculations for all rodless cylinders need to differentiate between final velocity and average velocity. For example: Stroking a 100-inch BC3 model in one second yields an average velocity of 100 inches per second. To properly determine the inertial forces for cushioning, it is important to know the

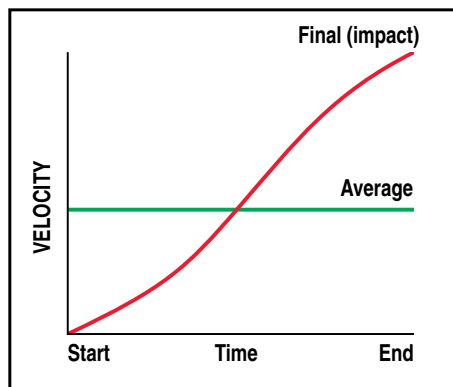

final (or impact) velocity. Rodless cylinders accelerate and decelerate at each end of the stroke. Therefore this acceleration must be considered (see diagram).

If final (or impact) velocity cannot be calculated directly, a reasonable guideline is to use 2 x average velocity.

PB & PB2 Service Parts Ordering - ALL Sizes

PB: Power-Block Rod Cylinder Slide SIZE	Inch (U.S. Standard)			
	06	10	17	20
Switch Hardware Kit	2506-9999	2506-9999	2506-9999	2506-9999
Reed Switch Magnet ¹	2506-9003	2510-9003	2517-9003	2520-9003
Hall-effect Switch Magnet ¹	2506-9004	2510-9004	2517-9004	2520-9004
BP: Stop Collar / Bumper Kit ²	2506-9002	2510-9002	2517-9002	2520-9002

PB2: Power-Block2 Rod Cylinder Slide SIZE	Inch (U.S. Standard)					
	08	10	17	20	32	52
Switch Hardware Kit	2506-9999	2506-9999	2506-9999	2506-9999	2506-9999	2506-9999
TN: T-Nuts	3410-1013	3410-1013	3415-1013	3415-1013	3420-1013	3420-1013

PART NUMBER ORDERING		CONFIG. CODE ORDERING
No Mounting Hardware or FE conn. included		Mounting Hardware & FE conn. included
PART NO.	DESCRIPTION	CODE
3600-9084	Switch Only, Reed, Form C, 5m	BT
3600-9085	Switch Only, Reed, Form C, Male Conn.	BM
3600-9082	Switch Only, Reed, Form A, 5m	RT
3600-9083	Switch Only, Reed, Form A, Male Conn.	RM
3600-9086	Switch Only, Triac, 5m	CT
3600-9087	Switch Only, Triac, Male Conn.	CM
3600-9090	Switch Only, Hall-effect, Sinking, 5m	KT
3600-9091	Switch Only, Hall-effect, Sinking, Male Conn.	KM
3600-9088	Switch Only, Hall-effect, Sourcing, 5m	TT
3600-9089	Switch Only, Hall-effect, Sourcing, Male Conn.	TM
2503-1025	Connector (Female) 5 meter lead	

NOTE: When ordered by Config. Code Female connector & all mounting hardware is included



Service Parts Ordering NOTES:

- 1 One Each
- 2 Kit includes: 2 (two) stop collars and 2 (two) 1/4" thick polyurethane external bumpers to help absorb impact shock

Switch Ordering NOTES:



To order field retrofit switch and hardware kits for all Tolomatic actuators: SW (Then the model and bore size, and type of switch required)

Example: SWPB10RT

(Hardware and Form A Reed switch with 5 meter lead for 0.625" bore PB Rod Cylinder Slide)



Replacing an existing switch on an actuator manufactured AFTER 7-1-1997

Order using PART NUMBER in table above



Replacing an existing switch on an actuator manufactured BEFORE 7-1-1997

Order using CONFIGURATOR CODE in table above

If replacing a quick-disconnect switch on an actuator manufactured BEFORE 7-1-1997 it will also be necessary to replace or require the female-end coupler with the in-line splice (see page PB_13)

PB & PB2 Ordering - All Sizes

MODEL, BORE, STROKE, BEARING OPTIONS

P B **2 0** **S K** **3 0** **D P** **B P** **B M** **2**

MODEL & MOUNTING

PB Power Block Rod
Cylinder Slide-
inch (U.S. Standard)

PB2 Power Block2 Rod
Cylinder Slide-
inch (U.S. Standard)

PB BORE SIZE

06 0.38" (10mm)
10 0.63" (16mm)
17 1.13" (27mm)
20 1.25" (32mm)

PB2 BORE SIZE

08 0.50" (13mm)
10 0.63" (16mm)
17 1.13" (27mm)
20 1.25" (32mm)
32 2.00" (51mm)
52 3.25" (83mm)

STROKE LENGTH

SK__ Enter desired stroke length from the code number in the table below

STROKE LENGTH	ORDER CODE									
	PB				PB2					
	06	10	17	20	08	10	17	20	32	52
0.5" (13mm)	05	05			05	05				
1.0" (25mm)	10	10	10	10	10	10	10	10	10	10
1.5" (38mm)	15	15			15	15				
2.0" (51mm)	20	20	20	20	20	20	20	20	20	20
3.0" (76mm)			30	30	30	30	30	30	30	30
4.0" (102mm)					40	40	40	40	40	40
5.0" (127mm)							50	50	50	50
6.0" (152mm)							60	60	60	60

BEARING TYPE

PB	PB2
Composite Bearings - NO Entry Required	LB Linear Bearings CB Composite Bearings

SWITCHES (PB_14)

(Quantity desired follows ordering code)

RM_ Reed Switch (Form A) with 5-meter lead/QD (Quick-disconnect)

RT_ Reed Switch (Form A) with 5-m lead

BM_ Reed Switch (Form C) with 5-meter lead/QD

BT_ Reed Switch (Form C) with 5-m lead

***KM**_ Hall-effect Sinking Switch with 5-meter lead/QD

***KT**_ Hall-effect Sinking Switch w/ 5-m lead

***TM**_ Hall-effect Sourcing Switch with 5-meter lead/QD

***TT**_ Hall-effect Sourcing Switch with 5-meter lead

CM_ TRIAC Switch with 5-meter lead/QD

CT_ TRIAC Switch with 5-meter lead

***MDR** Dual Magnet (Reed, Hall-effect, Triac)

*⊗ Not available for 05 size

STOP COLLARS/BUMPERS (PB ONLY)

BP For Bumpers/Stop Collars

DUAL TOOLING PLATE (PB ONLY)

DP For Dual Tooling Plate

T-NUTS (PB2 ONLY)

TN_ For T-Nuts, indicate number required

 **Not all codes listed are compatible with all options. Contact Tolomatic with any questions.**