

## Pneu-Turn Rotary Actuators

- Pneu-Turn Actuators 4.3-4.15
- Three-Position Pneu-Turn 4.16-4.18
- Engineering Specifications/  
Application Checklist 4.19-4.22



# Bimba Pneu-Turn Rotary Actuators



**TURN TO THE BIMBA PNEU-TURN® ROTARY ACTUATOR FOR THESE QUALITY FEATURES AT A LOWER COST:**

*The Bimba Pneu-Turn Rotary Actuator is available with these catalog options:*

- Angle Adjustment
- Bumpers
- Adjustable Cushions
- Dual Shaft
- Square Key
- MRS® Magnetic Position Sensing
- Spring Return
- Oil Service Seals
- High Temperature Option
- Ball Bearing
- Rear Shaft
- Hardened Shaft
- Anti-backlash Rack

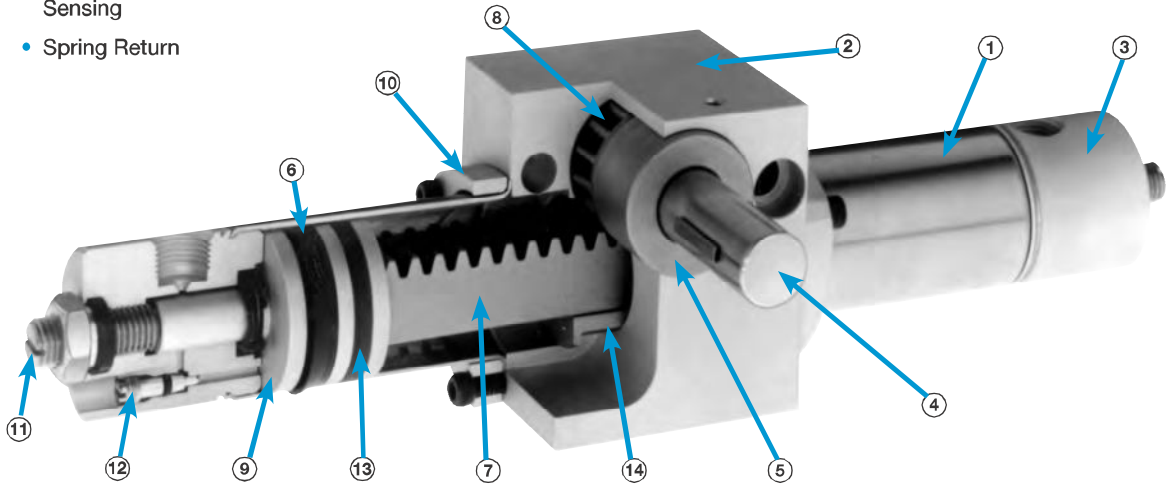

1. **CYLINDER BODIES** – 304 stainless steel for maximum seal life.
2. **ACTUATOR BODY** – High strength, anodized aluminum alloy for maximum corrosion protection.
3. **PORTING ENDS** – High strength, anodized aluminum alloy.
4. **SHAFT** – High strength, 303 stainless steel for maximum wear resistance and long life. (hardened steel optional).
5. **SHAFT BEARINGS** – Self-lubricating, sintered iron copper material for lower friction. (ball bearings optional).
6. **PISTON SEALS** – Buna "N", U-cup type for low breakaway friction and long life.
7. **RACK** – Carbon steel for maximum wear resistance.
8. **PINION** – High strength, alloy steel for greater durability.
9. **PISTON** – High strength, aluminum alloy.
10. **CYLINDER BODY RETAINER RING** – High strength, stainless steel for maximum corrosion protection.
11. **ANGLE ADJUSTMENT** – An option that allows 45° of adjustability each end.
12. **ADJUSTABLE CUSHIONS** – An option that controls deceleration at the end of the rotation.
13. **MRS® MAGNETIC POSITION SENSING** – An option that provides a magnet for sensing position.
14. **RACK SUPPORT** – Sintered brass material for increased load carrying capabilities.

# Bimba Pneu-Turn Rotary Actuators

## How to Order

The model number of Pneu-Turn Rotary Actuators consists of three alphanumeric clusters. These designate product type, series, angle of rotation and special options. Please refer to the charts below for an

example of model number PT-037090-A1DV. This is a 1-1/16" bore, single rack, 90° angle of rotation actuator with angle adjustment on both sides, dual shaft and high temperature option.

### PT - 037090 - A1DV

SERIES - TORQUE FACTOR	ANGLE OF ROTATION	OPTIONS
006 - 9/16" Bore, Single Rack 014 - 9/16" Bore, Double Rack 017 - 3/4" Bore, Single Rack 033 - 3/4" Bore, Double Rack 037 - 1-1/16" Bore, Single Rack 074 - 1-1/16" Bore, Double Rack 098 - 1-1/2" Bore, Single Rack 196 - 1-1/2" Bore, Double Rack 247 - 2" Bore, Single Rack 494 - 2" Bore, Double Rack Single Rack see page 4.5 Double Rack see page 4.7	045 - 45° 090 - 90° 180 - 180° 270 - 270° 360 - 360° Rotation angles up to 1080° are available. See page 4.19 for rotational tolerance.	A1 - Angle adjustment (both sides) A2 - Angle adjustment (counterclockwise rotation) A3 - Angle adjustment (clockwise rotation) B1 - Bumpers (both sides) B2 - Bumper (counterclockwise rotation) B3 - Bumper (clockwise rotation) C1 - Cushions (both sides) <sup>1</sup> C2 - Cushion (counterclockwise rotation) <sup>1</sup> C3 - Cushion (clockwise rotation) <sup>1</sup> D - Dual shaft E - Rear shaft (front portion of dual shaft removed; to accommodate hanging axial load) F - Hardened shaft <sup>2</sup> G - Polymer grease K - Square key <sup>3</sup> M - Magnetic position sensing <sup>4</sup> N - Low temperature option (-40°F) <sup>8</sup> Q1 - Internal Flow Control (both sides) <sup>9</sup> Q2 - Internal Flow Control (counterclockwise rotation only) <sup>9</sup> Q3 - Internal Flow Control (clockwise rotation only) <sup>9</sup> R - Ball bearing <sup>2</sup> S - Seals - oil service <sup>5</sup> T - Switch track <sup>6</sup> V - High temperature option (0°F to 400°F) X - Anti-backlash (for 1-1/16" - 2" bores only) <sup>7</sup> Z2 <sup>10</sup> - Spring return, side A single rack, bodies A and D double rack Z3 <sup>10</sup> - Spring return, side B single rack, bodies C and B double rack

To determine theoretical output torque (in.-lbs.), place a decimal point between the first and second digits of the series number. Then multiply that number by the air line pressure for the approximate torque produced.

For example, a PT-037-090 will produce an output torque of 0.37 times the air line pressure.

### Option Combination Availability

Due to design or compatibility restrictions, the following options may **not** be ordered in combination. For example, F and E options are not available in combination.

OPTIONS	A	B	C	D	E	F	N	Q	R*	S	X	Z
9/16" (006)	S	S	N/A	E	D,F,R,X	D,E,K	B,G,M,V	N/A	E	A,B		B,C
9/16" (014)		S	N/A	E	D,F,R,X	D,E,K	B,G,M,V	N/A	E	B		B,C
3/4" (017)	S	C,S	B,Q,S	E	D,F,R,X	D,E,K	B,G,M,Q,V	A,C,N,S	E	A,B,C		B,C
3/4" (033)		C,S	B,Q,S	E	D,F,R,X	D,E,K	B,G,M,Q,V	A,C,N,S	E	B,C		B,C
1-1/16" (037)		C,S	B,Q,S	E	D,F,R,X	D,E,K	B,G,M,Q,V	A,C,N,S	E	B,C	E,F	B,C
1-1/16" (074)		C,S	B,Q,S	E	D,F,R,X	D,E,K	B,G,M,Q,V	A,C,N,S	E	B,C	E,F	B,C
1-1/2" (098)		C,S	B,Q,S	E	D,F,R,X	D,E,K	B,G,M,Q,V	A,C,N,S	E	B,C	E,F	B,C
1-1/2" (196)		C,S	B,Q,S	E	D,F,R,X	D,E,K	B,G,M,Q,V	A,C,N,S	E	B,C	E,F	B,C
2" (247)		C,S	B,Q,S	E	D,F,R,X	D,E,K	B,G,M,Q,V	A,C,N,S	E	B,C	E,F	B,C
2" (494)		C,S	B,Q,S	E	D,F,R,X	D,E,K	B,G,M,Q,V	A,C,N,S	E	B,C	E,F	B,C

\*Temperature range of ball bearing option with high temperature option is 0°F to +250°F.

Option T - "Switch track" should only be ordered with options M or V if the actuator will be operated between -20° to 85°

<sup>1</sup> Not available in Series 006 or 014. See below for option combination availability. See page 4.6 and 4.8 for explanation of clockwise/counterclockwise.

<sup>2</sup> When ordering option -F, option -R must be ordered. -R option will include dowel pin holes. Dowel pin hole locations shown in Related Products section of this catalog.

<sup>3</sup> 006 and 014 have flat shaft.

<sup>4</sup> Option M can be ordered with option-V, but option V's rating will change to 180° F.

<sup>5</sup> Oil service applications require 40 psi at all times or leakage will occur. 1/8 NPT ports provided (orifice omitted) for 9/16" and 3/4" bores. For double rack models, oil service seals and 1/8" ports provided on bodies A and C only.

<sup>6</sup> Option T must be ordered in conjunction with Option M. Option M can be ordered with Option-V, but Option V's rating will change to 180° F. See Switch Products section of this catalog for additional switch information.

<sup>7</sup> Option X (Anti-backlash) is available in bore sizes 1-1/16", 1-1/2" and 2", single and double rack - up to 360° rotation. This option eliminates mid-rotational and end of rotation backlash in single rack models. It also eliminates mid-rotational backlash in double rack models. Double rack models do not have end of rotation backlash. All Pneu-Turns with this option include ball bearings Option R. Use this option to provide smooth rotation along with rotational precision.

<sup>8</sup> Low temperature bumpers not available.

<sup>9</sup> 3/4", 1-1/16", 1-1/2", 2" bore only.

<sup>10</sup> Z2 and Z3 options cannot be ordered together. If spring return on both sides is desired, contact Technical Support and request a special. Z2 may be combined with A2 or B2. Z3 may be combined with A3 or B3.

# Bimba Pneu-Turn Rotary Actuators

For Dowel Pin Hole Locations, see page 10.42

## Single Rack Models (in.)

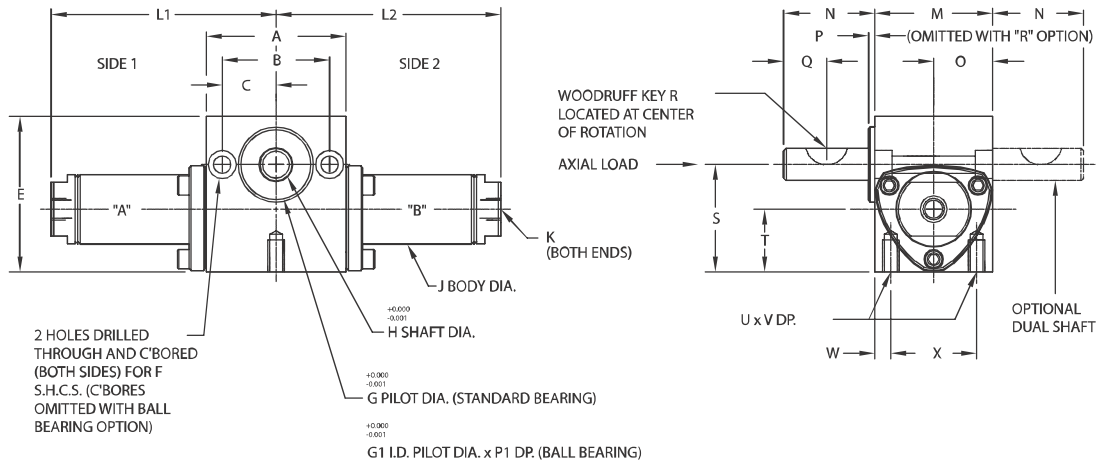

L1/L2 dimensions shown in chart on page 4.6.

Bore	A	B	C	E	E (With R Option)	F (C' Bores Omitted with Ball Bearing Option)	G (Std Bearing O.D. Pilot Dia.)
9/16" (006)	1.38	1.00	0.50	1.44	1.44	#8 S.H.C.S.	0.675
3/4" (017)	1.62	1.25	0.62	1.81	1.81	#10 S.H.C.S.	0.875
1-1/16" (037)	1.88	1.44	0.72	2.12	2.19	1/4" S.H.C.S.	0.968
1-1/2" (098)	2.38	1.81	0.90	2.81	2.84	5/16" S.H.C.S.	1.249
2" (247)	3.00	2.38	1.19	3.75	3.75	5/16" S.H.C.S.	1.749

Bore	G1 (Ball Bearing I.D. Pilot)	H	J	K	M	N	O	P	P1
9/16" (006)	0.750	0.250	0.61	#10-32 <sup>1</sup>	1.12	0.69	0.56	0.06	0.06
3/4" (017)	0.875	0.375	0.82	#10-32 <sup>1</sup>	1.37	1.06	0.69	0.06	0.06
1-1/16" (037)	1.125	0.500	1.12	1/8 NPT	1.75	1.31	0.88	0.06	0.09
1-1/2" (098)	1.375	0.625	1.56	1/8 NPT	2.25	1.38	1.12	0.09	0.09
2" (247)	1.875	0.875	2.08	1/4 NPT	2.56	2.00	1.28	0.11	0.10

Bore	Q	R <sup>2</sup>	S	T	U	V	W	X
9/16" (006)	0.31	#202.5	1.03	0.61	#8-32	0.44	0.19	0.75
3/4" (017)	0.50	#204	1.25	0.73	#10-24	0.38	0.19	1.00
1-1/16" (037)	0.62	#305	1.56	0.88	1/4-20	0.50	0.25	1.25
1-1/2" (098)	0.62	#405	2.09	1.16	5/16-18	0.62	0.31	1.62
2" (247)	0.75	#606	2.56	1.28	5/16-18	0.62	0.28	2.00

<sup>1</sup>Option-S ports are 1/8 NPT  
<sup>2</sup>Key dimensions on page 4.9.

# Bimba Pneu-Turn Rotary Actuators

## Single Rack Options (in.)

(Dimensional variations from standard as shown.)

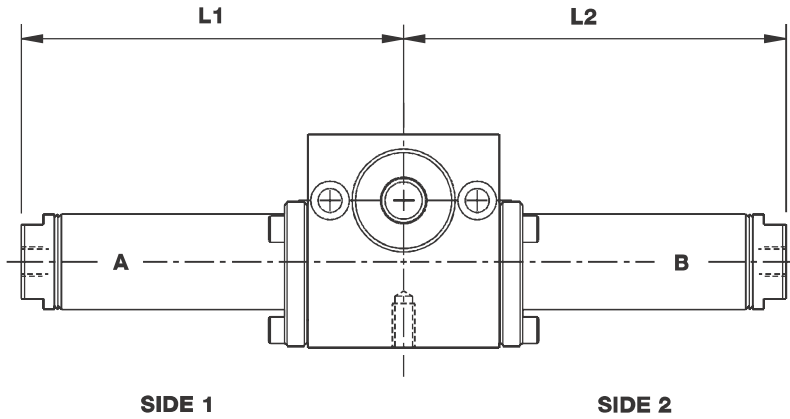

	9/16" (006)		3/4" (017)		1-1/16" (037)		1-1/2" (098)		2" (247)	
	L1	L2	L1	L2	L1	L2	L1	L2	L1	L2
Adder Per Degree of Rotation	0.0048	0.0048	0.0066	0.0066	0.0073	0.0073	0.0097	0.0097	0.0137	0.0137
Plus One Length Adder Below Per Side										
Base Unit (No Options)	1.52	1.52	1.63	1.63	2.03	2.03	2.34	2.34	2.84	2.84
Bumper Both Sides (B1)	1.64	1.64	1.77	1.77	2.18	2.18	2.49	2.49	3.04	3.04
Bumper CCW Side (B2)	1.52	1.64	1.63	1.77	2.03	2.18	2.34	2.49	2.84	3.04
Bumper CW Side (B3)	1.64	1.52	1.77	1.63	2.18	2.03	2.49	2.34	3.04	2.84
Cushion Both Sides (C1)	N/A	N/A	2.16	2.16	2.66	2.66	2.98	2.98	3.65	3.65
Cushion CCW Side (C2)	N/A	N/A	1.63	2.16	2.03	2.66	2.34	2.98	2.84	3.65
Cushion CW Side (C3)	N/A	N/A	2.16	1.63	2.66	2.03	2.98	2.34	3.65	2.84
Oil Service Seals (S)	1.93	1.93	2.18	2.18	2.34	2.34	2.77	2.77	3.38	3.38
Oil Service with Angle Adjustment (AS)	N/A	N/A	N/A	N/A	2.97	2.97	3.41	3.41	4.19	4.19

Note: Option A- Angle Adjustment and Option M- Magnetic Position Sensing is found on pages 4.9 and 4.10.

### "CCW Side" -

refers to the extreme rotation of the shaft in the counter-clockwise direction as viewed from the mounting pilot side of the actuator.

The location of the optional feature chosen will be on tube B for single rack actuators.

### "CW Side" -

refers to the extreme rotation of the shaft in the clockwise direction as viewed from the mounting pilot side of the actuator.

The location of the optional feature chosen will be on tube A for single rack actuators.

# Bimba Pneu-Turn Rotary Actuators

## Double Rack Models (in.)

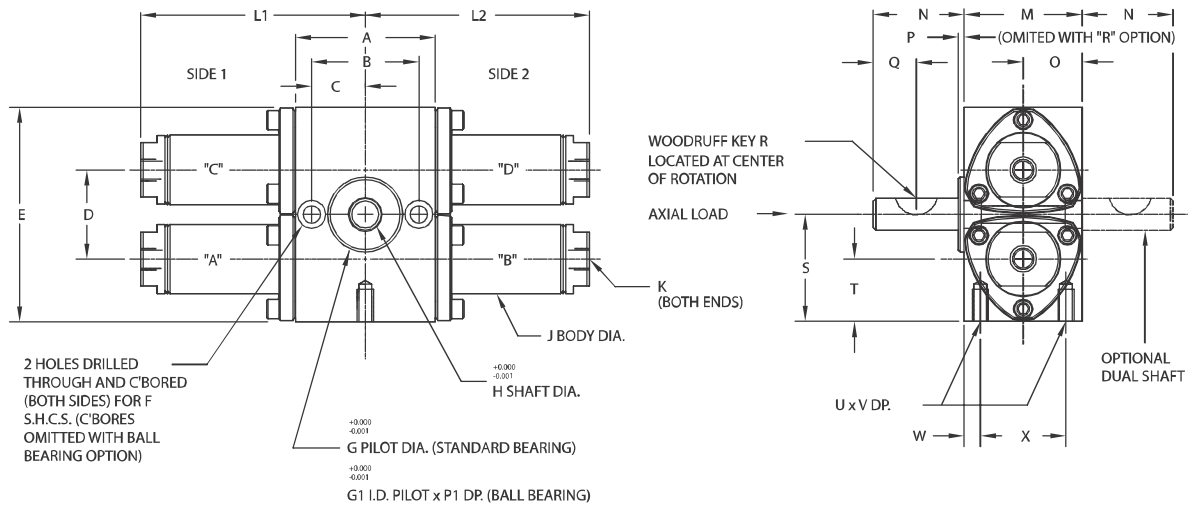

Note: Body retainer on 2" bore has 4 corners.  
L1/L2 dimensions shown in chart on page 4.8.

Bore	A	B	C	D	E	F (C' Bores Omitted with Ball Bearing Option)	G (Std Bearing O.D. Pilot Dia.)
9/16" (014)	1.38	1.00	0.50	0.83	2.06	#8 S.H.C.S.	0.675
3/4" (033)	1.62	1.25	0.62	1.04	2.50	#10 S.H.C.S.	0.875
1-1/16" (074)	1.88	1.44	0.72	1.36	3.12	1/4" S.H.C.S.	0.968
1-1/2" (196)	2.38	1.81	0.90	1.88	4.19	5/16" S.H.C.S.	1.249
2" (494)	3.00	2.38	1.19	2.56	5.13	5/16" S.H.C.S.	1.749

Bore	G1 (Ball Bearing I.D. Pilot)	H	J	K	M	N	O	P	P1
9/16" (014)	0.750	0.250	0.61	#10-32 <sup>1</sup>	1.12	0.69	0.56	0.06	0.06
3/4" (033)	0.875	0.375	0.82	#10-32 <sup>1</sup>	1.37	1.06	0.69	0.06	0.06
1-1/16" (074)	1.125	0.500	1.12	1/8 NPT	1.75	1.31	0.88	0.06	0.09
1-1/2" (196)	1.375	0.625	1.56	1/8 NPT	2.25	1.38	1.12	0.09	0.09
2" (494)	1.875	0.875	2.08	1/4 NPT	2.56	2.00	1.28	0.11	0.10

Bore	Q	R <sup>2</sup>	S	T	U	V	W	X
9/16" (014)	0.31	#202.5	1.03	0.61	#8-32	0.44	0.19	0.75
3/4" (033)	0.50	#204	1.25	0.73	#10-24	0.38	0.19	1.00
1-1/16" (074)	0.62	#305	1.56	0.88	1/4-20	0.50	0.25	1.25
1-1/2" (196)	0.62	#405	2.09	1.16	5/16-18	0.62	0.31	1.62
2" (494)	0.75	#606	2.56	1.28	5/16-18	0.62	0.28	2.00

<sup>1</sup>Option-S ports are 1/8 NPT (bodies "A" and "C" only).  
<sup>2</sup>Key dimensions on page 4.9.

# Bimba Pneu-Turn Rotary Actuators

## Double Rack Options (in.)

(Dimensional variations from standard as shown.)

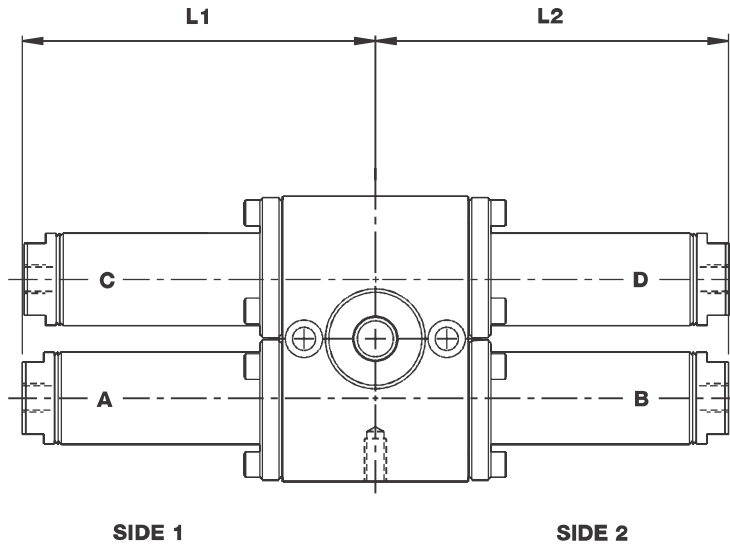

	9/16" (014)		3/4" (033)		1-1/16" (074)		1-1/2" (196)		2" (494)	
	L1	L2	L1	L2	L1	L2	L1	L2	L1	L2
Adder Per Degree of Rotation	0.0048	0.0048	0.0066	0.0066	0.0073	0.0073	0.0097	0.0097	0.0137	0.0137
<b>Plus One Length Adder Below Per Side</b>										
Base Unit (No Options)	1.52	1.57	1.63	1.68	2.03	2.08	2.34	2.39	2.84	2.89
Bumper Both Sides (B1)	1.64	1.57	1.77	1.68	2.18	2.08	2.49	2.39	3.04	2.89
Bumper CCW Side (B2)	1.64	1.57	1.77	1.68	2.18	2.08	2.49	2.39	3.04	2.89
Bumper CW Side (B3)	1.64	1.57	1.77	1.68	2.18	2.08	2.49	2.39	3.04	2.89
Cushion Both Sides (C1)	N/A	N/A	2.16	1.68	2.66	2.08	2.98	2.39	3.65	2.89
Cushion CCW Side (C2)	N/A	N/A	2.16	1.68	2.66	2.08	2.98	2.39	3.65	2.89
Cushion CW Side (C3)	N/A	N/A	2.16	1.68	2.66	2.08	2.98	2.39	3.65	2.89
Oil Service Seals (S)	1.93	1.57	2.18	1.68	2.34	2.08	2.77	2.39	3.38	2.89
Oil Service with Angle Adjustment (AS)	N/A	N/A	N/A	N/A	2.97	2.08	3.41	2.39	4.19	2.89

### “CCW Side” –

refers to the extreme rotation of the shaft in the counter-clockwise direction as viewed from the mounting pilot side of the actuator.

The location of the optional feature chosen will be on tube C for single rack actuators.

### “CW Side” –

refers to the extreme rotation of the shaft in the clockwise direction as viewed from the mounting pilot side of the actuator.

The location of the optional feature chosen will be on tube A for double rack actuators.

# Bimba Pneu-Turn Rotary Actuators

## Options

### MRS® Magnetic Position Sensing

Magnetic pistons are located on the A and B tubes of both the single and double rack rotary actuators, guaranteeing switch operation at any point in the rotation.

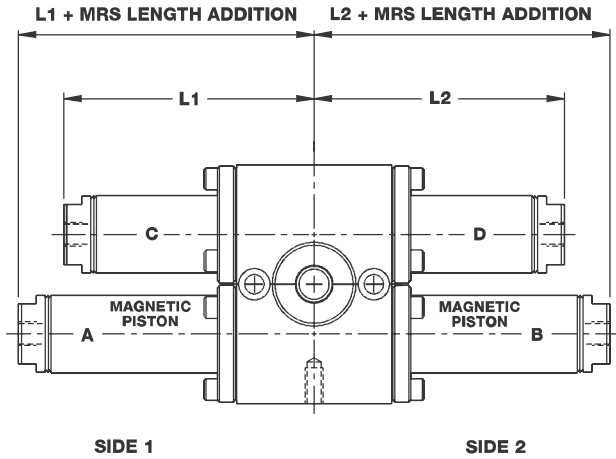
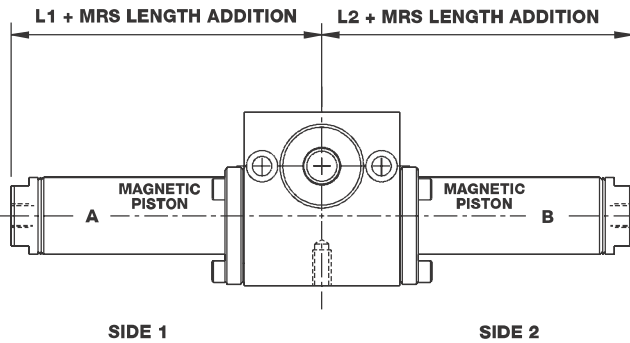

### MRS® Length Adder (in.)

Degrees	006/014	017/033	037/074	098/196	247/494
45°	0.66	0.66	0.75	0.75	0.75
90°	0.55	0.52	0.59	0.53	0.44
180°	0.34	0.22	0.26	0.09	0.00
270°	0.12	0.00	0.00	0.00	0.00
360°	0.00	0.00	0.00	0.00	0.00

### Woodruff Key (in.)

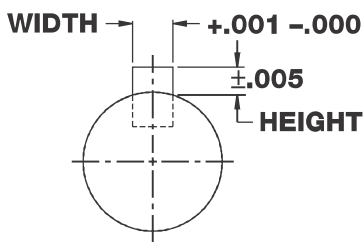

Key No.	Width	Height
202.5	0.0625	0.032
204	0.0625	0.032
305	0.0938	0.047
405	0.1250	0.063
606	0.1875	0.094

### Flat Key (in.) (006 and 014)

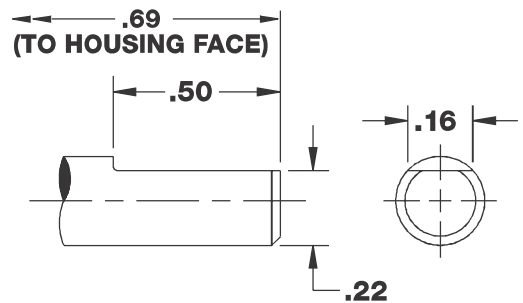

### Square Key Option (in.)

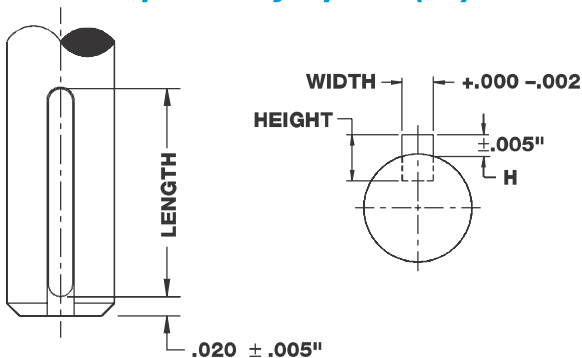

Bore Size	Length	Width	Height	H
3/4" (017 / 033)	.718	.094	.094	.047
1-1/16" (037 / 074)	.797	.125	.125	.063
1-1/2" (098 / 196)	.797	.188	.188	.094
2" (247 / 494)	1.781	.25	.25	.125



# Bimba Pneu-Turn Rotary Actuators

## Option Dimensions (in.)

**Cushion  
(C Option)**

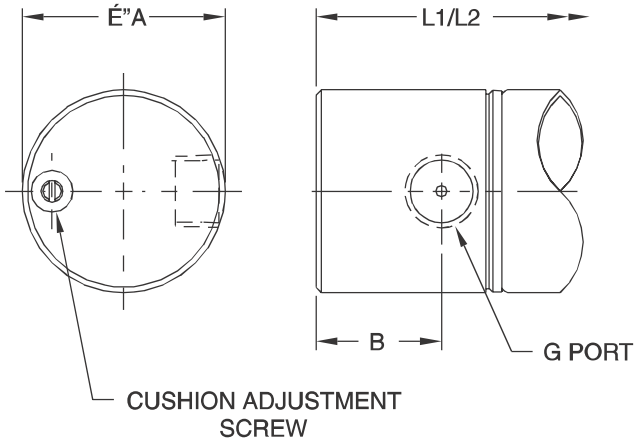

**Angle Adjustment with  
Oil Service Seals (AS Option)**

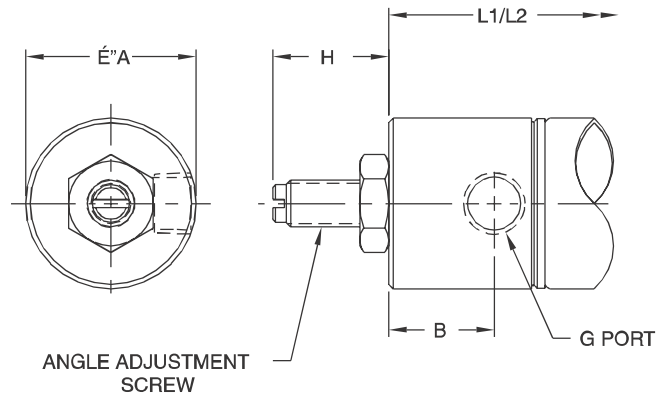

**Angle Adjustment with  
Cushion (AC Option)**

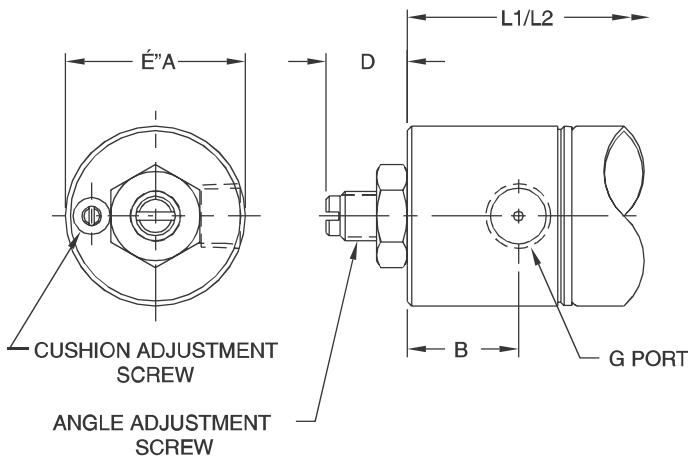

**Angle Adjustment  
(A Option)**

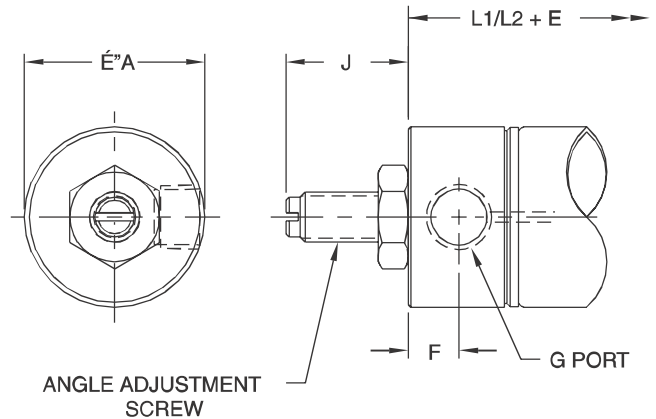

Bore	A	B	D	E	F	G	H	J
9/16" (006)	0.81	N/A	N/A	0.23	0.24	#10-32	N/A	0.53
9/16" (014)	0.81	N/A	N/A	0.23	0.24	#10-32	N/A	0.53
3/4" (017)	0.87	0.41	0.48	0.22	0.23	#10-32	N/A	0.71
3/4" (033)	0.87	0.41	0.48	0.22	0.23	#10-32	N/A	0.71
1-1/16" (037)	1.11	0.69	0.51	0.40	0.31	1/8 NPT	0.76	0.76
1-1/16" (074)	1.11	0.69	0.51	0.40	0.31	1/8 NPT	0.76	0.76
1-1/2" (098)	1.56	0.77	0.60	0.42	0.34	1/8 NPT	0.94	0.94
1-1/2" (196)	1.56	0.77	0.60	0.42	0.34	1/8 NPT	0.94	0.94
2" (247)	2.08	0.87	0.80	0.53	0.41	1/4 NPT	1.28	1.28
2" (494)	2.08	0.87	0.80	0.53	0.41	1/4 NPT	1.28	1.28

# Bimba Pneu-Turn Rotary Actuators

## Option N

### Low Temperature Seals

Option N - Low Temperature Operation is now available as a standard catalog offering.

Pneu-Turns with seals and lubricant allowing operation to minus 40 degrees F can now be ordered directly from the catalog. Please note when ordering this option that cylinder performance may be affected beginning at temperatures below minus 20 degrees F.

Operational Note: Dry air with a dew point below the lowest temperature the actuator will experience or dry nitrogen is recommended.

Product Availability - 3 business days

## Option Q

### Internal Flow Control

Internal flow control is now available as a standard catalog option in bore sizes 3/4", 1-1/16", 1-1/2", and 2"; both single and double rack models.

Use this option as a space saving feature and to avoid "tampering" associated with externally installed flow controls.

Flow control is achieved using a sealing disk that restricts the flow of air to the port when the piston moves towards the end cap. The restricted air is channeled through a small orifice within the end cap, on its way to the exhaust port. Controlling the flow through this orifice is achieved by adjusting a screw located on the face of the end cap. Single rack units: Clockwise (CW) and counter-clockwise (CCW) rotational flow is controlled using the end cap adjustment screw, opposite the direction of the shaft. Double rack units: CW rotation flow is adjusted using the screw in the lower end cap; CCW rotational flow is adjusted using the screw in the upper end cap. Bore sizes 3/4" and 1-1/16" provide three turns of adjustment. All larger bore sizes provide four turns of adjustment.

#### Option designators

- Q1 - Internal flow control (both sides)
- Q2 - Internal flow control (counter-clockwise rotation)
- Q3 - Internal flow control (clockwise rotation)

Product Availability - 3 business days

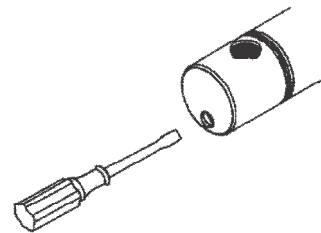

#### Option Q - Dimensional Variations from Standard (in.)

Single Rack	9/16" (006)		3/4" (017)		1-1/16" (037)		1-1/2" (098)		2" (247)	
	L1	L2	L1	L2	L1	L2	L1	L2	L1	L2
Adder per Degree of Rotation			0.0066	0.0066	0.0073	0.0073	0.0097	0.0097	0.0137	0.0137
Flow Control Both Sides (Q1)	N/A	N/A	2.16	2.16	2.66	2.66	2.98	2.98	3.65	3.65
Flow Control Both Sides (Q2)	N/A	N/A	1.63	2.16	2.03	2.66	2.34	2.98	2.84	3.65
Flow Control Both Sides (Q3)	N/A	N/A	2.16	1.63	2.66	2.03	2.98	2.34	3.65	2.84

Double Rack	Degree of Rotation Adder Same as Single Rack									
	9/16" (014)		3/4" (033)		1-1/16" (074)		1-1/2" (196)		2" (494)	
	L1	L2	L1	L2	L1	L2	L1	L2	L1	L2
Flow Control Both Sides (Q1)	N/A	N/A	2.16	1.68	2.66	2.08	2.98	2.39	3.65	2.89
Flow Control Both Sides (Q2)	N/A	N/A	2.16	1.68	2.66	2.08	2.98	2.39	3.65	2.89
Flow Control Both Sides (Q3)	N/A	N/A	2.16	1.68	2.66	2.08	2.98	2.39	3.65	2.89

Refer to pages 4.5-4.10 for other standard option dimensional information.

# Bimba Pneu-Turn Rotary Actuators

## Switch Track (T Option)

Track Locations (All other dimensions remain unchanged)

STANDARD "T" ALL BORES

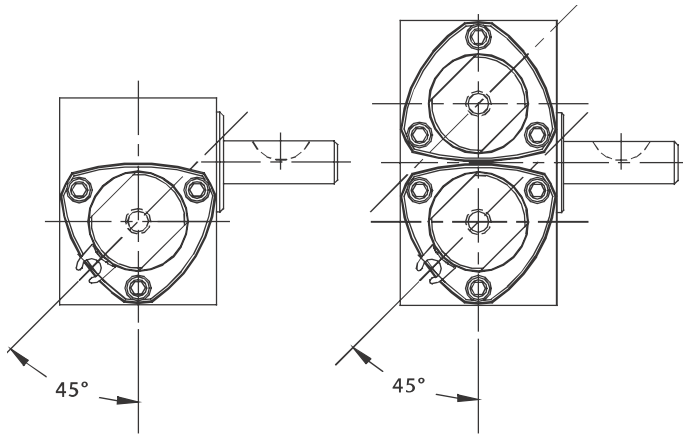

ALL OTHER OPTIONS  
ALL BORES EXCEPT 3/4 & 9/16

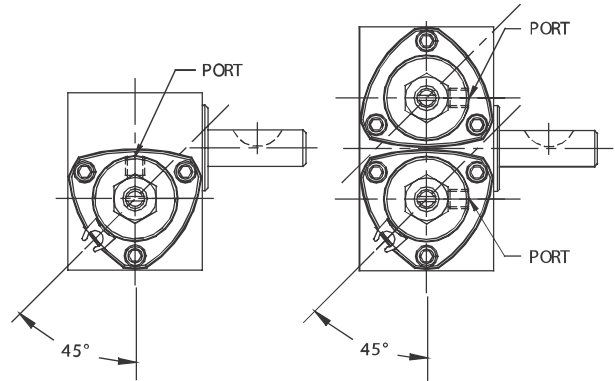

"AT" FOR 3/4 9/16 BORE

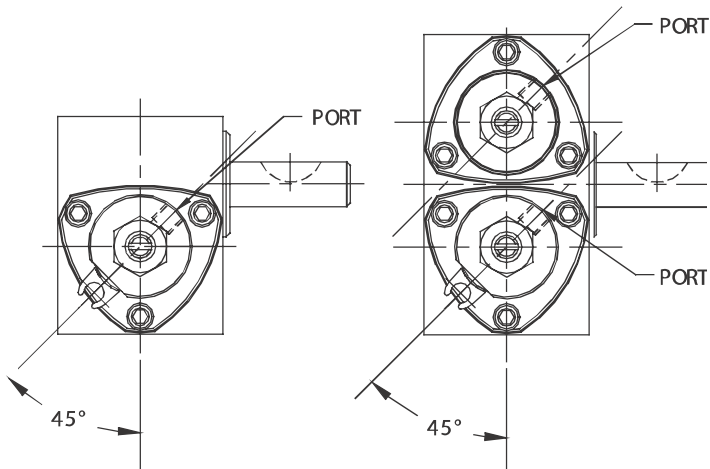

"ACT" & "CT" FOR 3/4 BORE

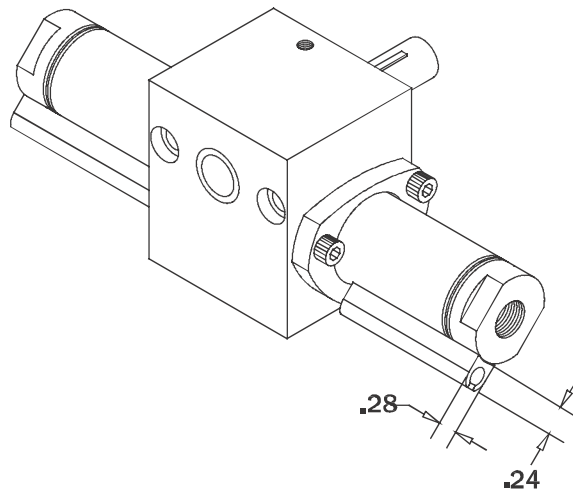
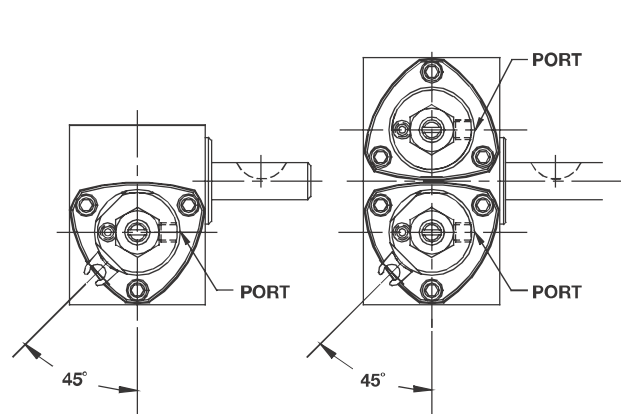

# Bimba Pneu-Turn Rotary Actuators

## Double Rack Z2 and Z3 Option (in.)

(Dimensional variations from standard as shown.)

**Z2 Option**  
Adder applies to L1 and L2,  
bodies A and D only

**Z3 Option**  
Adder applies to L1 and L2,  
bodies C and B only

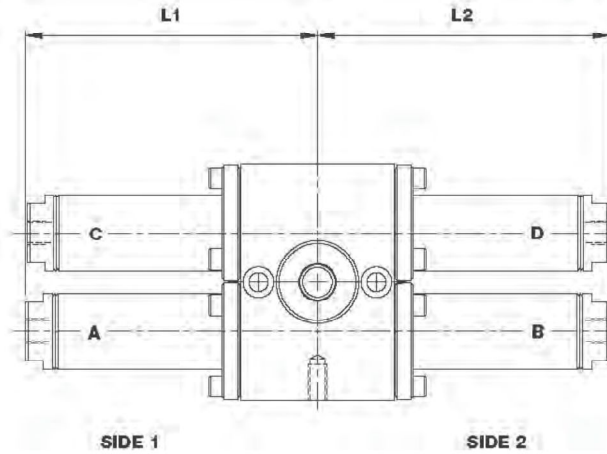

## Single Rack Z2 and Z3 Option (in.)

(Dimensional variations from standard as shown.)

**Z2 Option**  
Adder applies to  
L1 dimension

**Z3 Option**  
Adder applies to  
L2 dimension

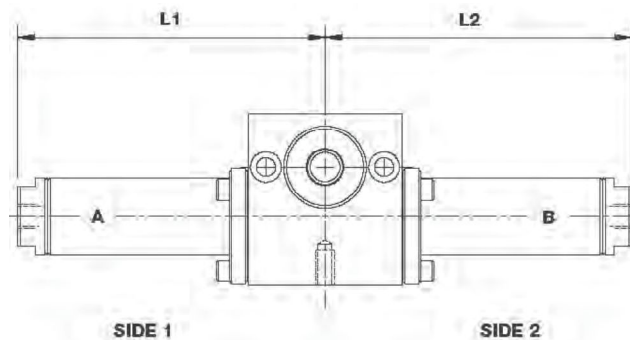

### Length Adder for Return Spring Option in Inches, per Body

Bore Size	0-75°	0-90°	0-120°	0-150°	76-150°	91-180°	151-225°	121-240°	181-270°	151-300°	226-300°	241-360°	271-360°	301-360°
9/16"		.688				1.313			1.938				2.563	
3/4"				.750						1.438				2.126
1-1/16"			.813					1.375				1.937		
1-1/2"		.751				1.439			2.127				2.815	
2"	1.262				2.262		2.512				4.450			4.812

Bore Size	Torque generated by spring (in-lbs.)	
	Pre-load	Final
9/16"	0.5	1.0
3/4"	1.0	2.0
1-1/16"	1.0	2.5
1-1/2"	4.0	8.0
2"	12.0	24.0

# Bimba Pneu-Turn Rotary Actuators

## Repair Parts

### Standard Shaft

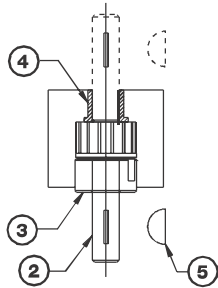

### Ball Bearing (R) Option

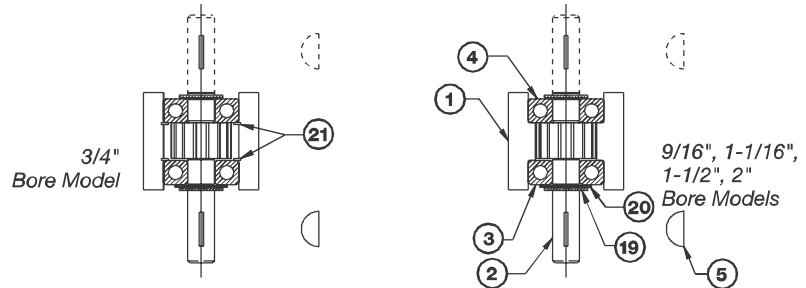

### Single Rack Model

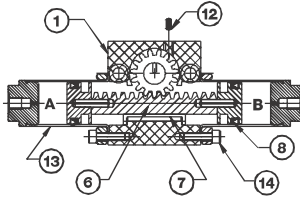

### Double Rack Model

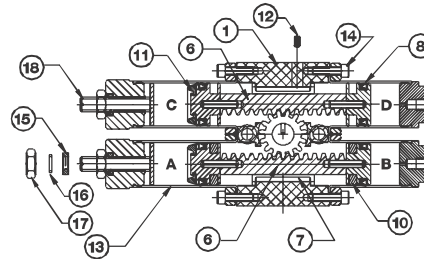

## Repair Parts

No.	Part Description	Quantity Required	
		Single	Double
PT-1	Actuator Body	1	1
PT-2	Shaft/Pinion Assembly	1	1
PT-3	Front Shaft Bearing	1	1
PT-4	Rear Shaft Bearing	1	1
PT-5	Shaft Key	1	1
PT-6	Piston/Rack Assembly (Includes Rack, Roll Pins and 2 Pistons)	1	2
PT-7	Rack Support	1	2
PT-8	Piston Seal <sup>1</sup>	2	4
PT-9	Piston Wear Ring (Required for Oil Service only)	2	2
PT-10	Magnet	2	2
PT-11	Bumper	2	2
PT-12	Bearing Retainer Set Screw	1	1
PT-13	Cylinder Body Assembly (Includes Body, End Cap, and Retainer Ring)	2	4
PT-14	Cylinder Body Retainer Cap Screw <sup>4</sup>	6	12
PT-15	Cylinder Body Thread Seal	2	2
PT-16	Cylinder Body Thread Seal Ring	2	2
PT-17	Cylinder Body Jam Nut	2	2
PT-18	Angle Adjustment Screw	2	2
PT-19	Retaining Ring	2	2
PT-20	Shim Package	1	1
PT-21	Shaft Spacers <sup>2</sup>	1	1

## Repair Kits

Bearing Kit (K-A-PT) <sup>3</sup>		
PT-3	Front Shaft Bearing	1
PT-4	Rear Shaft Bearing	1

Shaft Kit (K-S-PT)		
PT-2	Shaft/Pinion Assembly	1
PT-5	Shaft Key	1

Seal Kit (K-L-PT) <sup>1</sup>		
PT-8	Piston Seals	2

<sup>1</sup> Double Rack Models require two repair kits per rotary actuator.

*Oil Service Option: Single Rack models require four oil service seals or two oil service seal kits. Double Rack models require four oil service seals and two standard seals or two oil service seal kits and one standard seal kit.*

<sup>2</sup> Used on 3/4" bore single and double rack units with Ball Bearing option.

<sup>3</sup> Bearing Kit for Ball Bearings includes retaining rings and shim package.

<sup>4</sup> 2" bore requires 8 or 16.

# Bimba Pneu-Turn Rotary Actuators

## How to Order

**EXAMPLE:** Customer needs to replace the upper piston/rack assembly on a PT-033-180-C1DM. Order is placed as:

**PT - 6 - 33 - 180 - C1 - CD**  
A                      B                      C                      D                      E

- A. Repair Kit Part Number**
- B. Series code - (Bore Size)**

English	Metric
**006=06	**011=11
014=14	022=22
**017=17	**027=27
033=33	054=54
**037=37	**060=60
074=74	121=12
**098=98	**161=16
196=19	321=32
**247=24	**404=40
494=49	808=80

\* Designates parts common to both Single and Double Rack Models. Use SINGLE Rack series code only.  
 \*\* Single Rack Model.  
 # Used on 3/4 inch Bore with Ball Bearing Option.

- C. Rotation** - Rotation is only needed in **PT-6** and **PT-13**
- D. Options** - See Chart Below. Reference **OPTION COMBINATION AVAILABILITY CHART** in catalog for option compatibility. Options A, B and C must designate a 1, 2, or 3 (e.g. A1, B1, C1)
- E. Location** - For Bodies & Racks on Double Rack Models (**PT-6**, AB or CD) or (**PT-13**, A, B, C, or D)  
 For Bodies on Single Rack Models (**PT-13**, A or B)

Part No.	Part Description	Options	Location
<b>PT-1</b>	ACTUATOR BODY	<u>only</u> possible option needed <b>R</b>	
<b>*PT-2</b>	SHAFT/PINION ASSEMBLY	<u>only</u> possible options needed <b>D, E, F, K, R</b>	
<b>*PT-3</b>	FRONT SHAFT BEARING	<u>only</u> possible option needed <b>R</b>	
<b>*PT-4</b>	REAR SHAFT BEARING	<u>only</u> possible option needed <b>R</b>	
<b>*PT-5</b>	SHAFT KEY	<u>only</u> possible option needed <b>K</b>	
<b>PT-6</b>	PISTON/RACK ASSEMBLY	<u>only</u> possible options needed <b>B, C, M, S, X</b>	AB or CD
<b>*PT-7</b>	RACK SUPPORT	<u>only</u> possible option needed <b>X</b>	
<b>*PT-8</b>	PISTON SEAL	<u>only</u> possible options needed <b>S, V</b>	
<b>*PT-9</b>	PISTON WEAR RING	no options	
<b>*PT-10</b>	MAGNET	no options	
<b>*PT-11</b>	BUMPER	<u>only</u> possible options needed <b>V</b>	
<b>*PT-12</b>	BEARING RETAINER SET SCREW	no options	
<b>PT-13</b>	BODY ASSEMBLY	<u>only</u> possible options needed <b>A, B, C, M, S, T, V</b>	A, B, C, or D
<b>*PT-14</b>	BODY RETAINER CAP SCREW	no options	
<b>*PT-15</b>	BODY THREAD SEAL	<u>only</u> possible options needed <b>V</b>	
<b>*PT-16</b>	BODY THREAD SEAL RING	no options	
<b>*PT-17</b>	BODY JAM NUT	no options	
<b>*PT-18</b>	ANGLE ADJ. SCREW	<u>only</u> possible options needed <b>C, S (A if with S)</b>	
<b>*PT-19</b>	RETAINING RING	no options	
<b>*PT-20</b>	SHIM PACKAGE	no options	
<b>#PT-21</b>	SHAFT SPACERS	no options	
<b>*K-A-PT</b>	BEARING KIT	<u>only</u> possible option needed <b>R</b>	
<b>*K-L-PT</b>	SEAL KIT	<u>only</u> possible options needed <b>S, V, N</b>	
<b>*K-S-PT</b>	SHAFT KIT	<u>only</u> possible options needed <b>D, E, F, K, R</b>	

# Bimba Pneu-Turn Rotary Actuators

## Three-Position Pneu-Turn



The Three-Position Pneu-Turn rotary actuators, in all bore sizes; both single and double rack can now be ordered as a standard catalog option.

## How to Order

The model number for the Three-Position Pneu-Turn consists of alphanumeric characters. They designate the product; bore size, total rotation, degrees to mid-position, position of the shaft key at the mid-rotational position and options. The example below is for a 1-1/2" bore, single rack model with 225 degrees of total rotation, 45 degrees of rotation to the middle position, the key located at mid-position 8 and angle adjustment on both sides.

### PT - 098225/045-8A1

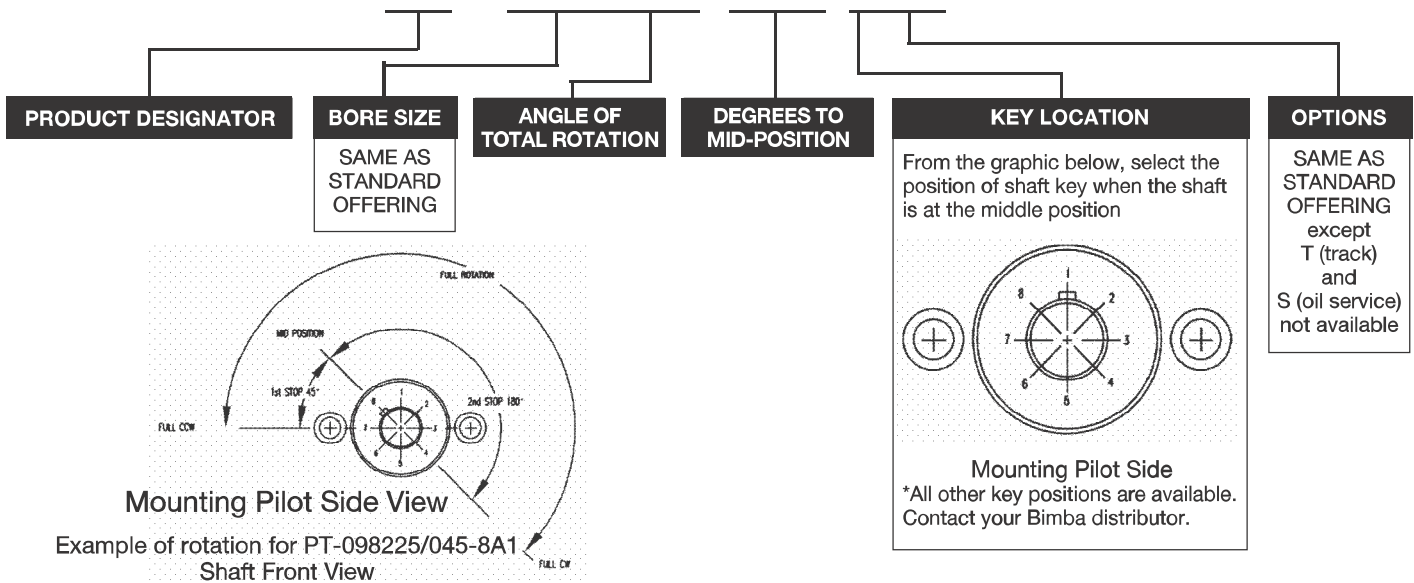

### Option Combination Availability

This chart provides the options that **cannot** be combined due to design or compatibility restrictions. For example, F and E options **are not** available in combination.

Option Series	A	B	C	D	E	F	G	K	M	N	Q	R	S	V	X
9/16" Single	S	N,Q,S	N/A	E,F	D,F,R	D,E,K	N,S	F	N	B,G,M,V	N/A	E	A,B,G	N	N/A
9/16" Double	S	N,Q,S	N/A	E,F	D,F,R	D,E,K	N,S	F	N	B,G,M,V	N/A	E	A,B,G	N	N/A
3/4" Single	Q,S	C,N,S	B,Q,S	E,F	D,F,R	D,E,K	N,S	F	N	B,G,M,Q,V	A,C,N,S	E	A,B,C,G,Q	N	N/A
3/4" Double	Q,S	C,N,S	B,Q,S	E,F	D,F,R	D,E,K	N,S	F	N	B,G,M,Q,V	A,C,N,S	E	A,B,C,G,Q	N	N/A
1-1/16" Single	Q	C,N,S	B,Q,S	E,F	D,F,R,X	D,E,K,X	N,S	F	N	B,G,M,Q,V	A,C,N,S	E	B,C,G,Q	N	E,F
1-1/16" Double	Q	C,N,S	B,Q,S	E,F	D,F,R,X	D,E,K,X	N,S	F	N	B,G,M,Q,V	A,C,N,S	E	B,C,G,Q	N	E,F
1-1/2" Single	Q	C,N,S	B,Q,S	E,F	D,F,R,X	D,E,K,X	N,S	F	N	B,G,M,Q,V	A,C,N,S	E	B,C,G,Q	N	E,F
1-1/2" Double	Q	C,N,S	B,Q,S	E,F	D,F,R,X	D,E,K,X	N,S	F	N	B,G,M,Q,V	A,C,N,S	E	B,C,G,Q	N	E,F
2" Single	Q	C,N,S	B,Q,S	E,F	D,F,R,X	D,E,K,X	N,S	F	N	B,G,M,Q,V	A,C,N,S	E	B,C,G,Q	N	E,F
2" Double	Q	C,N,S	B,Q,S	E,F	D,F,R,X	D,E,K,X	N,S	F	N	B,G,M,Q,V	A,C,N,S	E	B,C,G,Q	N	E,F

## Three-Position List Price Adders

Bore Size	9/16"		3/4"		1-1/16"		1-1/2"		2"	
	Single (006)	Double (014)	Single (017)	Double (033)	Single (037)	Double (074)	Single (098)	Double (196)	Single (247)	Double (494)
Three Position Base Adder	\$90.55	\$115.10	\$90.55	\$115.10	\$100.20	\$136.20	\$112.95	\$164.35	\$138.75	\$207.30
**Adder per 45 degree Rotation	2.55	4.90	2.55	4.90	3.35	6.55	3.80	7.15	4.15	7.80

\*\*The 45-degree rotational adder shown above includes the base and three-position requirement. No additional rotational adder is required.

Option list prices are the same as the standard offering.

All product is sold F.O.B. shipping point. Prices are subject to change without notice.

# Bimba Pneu-Turn Rotary Actuators

## Three-Position Pneu-Turn

Port A provides Full CCW position

Port B provides Full CW position

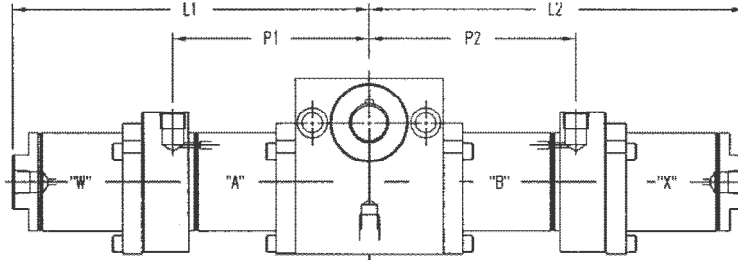

Ports W and X provide mid-position

### Single Rack Model Dimensions

	9/16" (006)				3/4" (017)				1-1/16" (037)			
	P1	P2	L1	L2	P1	P2	L1	L2	P1	P2	L1	LR
Degrees of Full Rotation	full rot. 0.0048	full rot. 0.0048	full rot. 0.0048	full rot. 0.0048	full rot. 0.0066	full rot. 0.0066	full rot. 0.0066	full rot. 0.0066	full rot. 0.0073	full rot. 0.0073	full rot. 0.0073	full rot. 0.0073
Adder per degree of rotation	2nd stop N/A	1st stop N/A	2nd stop 0.0048	1st stop 0.0048	2nd stop N/A	1st stop N/A	2nd stop 0.0066	1st stop 0.0066	2nd stop N/A	1st stop N/A	2nd stop 0.0073	1st stop 0.0073
Base Unit (No Option)	1.41	1.41	2.82	2.82	1.63	1.63	3.05	3.05	2.03	2.03	3.89	3.89
Bumpers Both Sides (B1)	1.53	1.53	3.06	3.06	1.77	1.77	3.33	3.33	2.18	2.18	4.19	4.19
Bumper CCW Side (B2)	1.41	1.53	2.82	3.06	1.63	1.77	3.05	3.33	2.03	2.18	3.89	4.19
Bumper CW Side (B3)	1.53	1.41	3.06	2.82	1.77	1.63	3.33	3.05	2.18	2.03	4.19	3.89
Cushion/Flow Both Sides (C1) (Q1)	N/A	N/A	N/A	N/A	1.63	1.63	3.58	3.58	2.03	2.03	4.51	4.51
Cushion/Flow CCW Side (C2) (Q2)	N/A	N/A	N/A	N/A	1.63	1.63	3.05	3.58	2.03	2.03	3.89	4.51
Cushion/Flow CW Side (C3) (Q3)	N/A	N/A	N/A	N/A	1.63	1.63	3.58	3.05	2.03	2.03	4.51	3.89
Angle Adjustment Both Sides (A1)	1.41	1.41	3.05	3.05	1.63	1.63	3.27	3.27	2.03	2.30	4.28	4.28
Angle Adjustment CCW Side (A2)	1.41	1.41	2.82	3.05	1.63	1.63	3.05	3.27	2.03	2.03	3.89	4.28
Angle Adjustment CW Side (A3)	1.41	1.41	3.05	2.82	1.63	1.63	3.27	3.05	2.03	2.03	4.28	3.89

\*\*Select Magnetic Position Sensing adder from MRS table

	1-1/2" (098)				2" (247)			
	P1	P2	L1	L2	P1	P2	L1	L2
Degrees of Full Rotation	full rot. 0.0097	full rot. 0.0097	full rot. 0.0097	full rot. 0.0097	full rot. 0.0137	full rot. 0.0137	full rot. 0.0137	full rot. 0.0137
Adder per degree of rotation	2nd stop N/A	1st stop N/A	2nd stop 0.0048	1st stop 0.0048	2nd stop N/A	1st stop N/A	2nd stop 0.0066	1st stop 0.0066
Base Unit (No Option)	2.28	2.28	4.39	4.39	2.81	2.81	5.13	5.13
Bumpers Both Sides (B1)	2.43	2.43	4.69	4.69	3.01	3.01	5.53	5.53
Bumper CCW Side (B2)	2.28	2.43	4.39	4.69	2.81	3.01	5.13	5.53
Bumper CW Side (B3)	2.43	2.28	4.69	4.39	3.01	2.81	5.53	5.13
Cushion/Flow Both Sides (C1) (Q1)	2.28	2.28	5.03	5.03	2.81	2.81	5.95	5.95
Cushion/Flow CCW Side (C2) (Q2)	2.28	2.28	4.39	5.03	2.81	2.81	5.13	5.95
Cushion/Flow CW Side (C3) (Q3)	2.28	2.28	5.03	4.39	2.81	2.81	5.95	5.13
Angle Adjustment Both Sides (A1)	2.28	2.28	4.80	4.80	2.81	2.81	5.66	5.66
Angle Adjustment CCW Side (A2)	2.28	2.28	4.39	4.80	2.81	2.81	5.13	5.66
Angle Adjustment CW Side (A3)	2.28	2.28	4.80	4.39	2.81	2.81	5.66	5.13

\*\*Select Magnetic Position Sensing adder from MRS table

MRS Length Adder (in.)					
Total Rotation Degrees	006/014	017/033	037/074	098/196	247/494
45°	0.66	0.66	0.75	0.75	0.75
90°	0.55	0.52	0.59	0.53	0.44
180°	0.34	0.22	0.26	0.09	0.00
270°	0.12	0.00	0.00	0.00	0.00
360°	0.00	0.00	0.00	0.00	0.00

**Note:**

Overall length calculator spreadsheet available. Contact the Technical Assistance Center for details.

Single rack overall width calculation: PT-098180/045-8C1--Using the chart above, calculate L1 and L2 dimensions as follows:  
 L1 = Total rotation (180) \* (.0097) Full rotation adder + Degrees to 2nd stop (135) \* (.0097) 2nd stop rotation adder + Cushion adder (5.03")  
 L2 = Total rotation (180) \* (.0097) Full rotation adder + Degrees to 1st stop (45) \* (.0097) 1st stop rotation adder + Cushion adder (5.03")  
 [L1 = (1.746" + 1.310" + 5.03") = 8.086"] + [L2 = (1.746" + .437 + 5.03") = 7.213"]; Total width = 8.086" + 7.213" = 15.30"



# Bimba Pneu-Turn Rotary Actuators

## Three-Position Pneu-Turn

Ports A and D provide Full CCW position

Ports B and C provide Full CW position

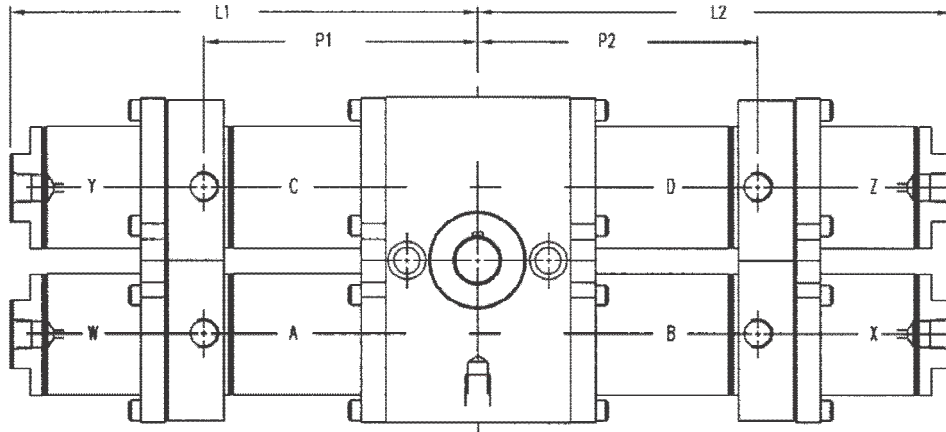

Ports W, X, Y, and Z provide mid-position

### Double Rack Model Dimensions

	9/16" (014)				3/4" (033)				1-1/16" (074)			
	P1	P2	L1	L2	P1	P2	L1	L2	P1	P2	L1	LR
Degrees of Full Rotation	full rot.	full rot.	full rot.	full rot.	full rot.	full rot.	full rot.	full rot.	full rot.	full rot.	full rot.	full rot.
Adder per degree of rotation	0.0048	0.0048	0.0048	0.0048	0.0066	0.0066	0.0066	0.0066	0.0073	0.0073	0.0073	0.0073
*Degrees to longest stop	stop rot.	stop rot.	stop rot.	stop rot.	stop rot.	stop rot.	stop rot.	stop rot.	stop rot.	stop rot.	stop rot.	stop rot.
Adder per degree of rotation	N/A	N/A	0.0048	0.0048	N/A	N/A	0.0066	0.0066	N/A	N/A	0.0073	0.0073
Base Unit (No Option)	1.41	1.46	2.82	2.87	1.63	1.68	3.05	3.10	2.03	2.08	3.89	3.94
Bumpers Both Sides (B1)	1.53	1.46	3.06	2.87	1.77	1.68	3.33	3.10	2.18	2.08	4.19	3.94
Bumper CCW Side (B2)	1.53	1.46	3.06	2.87	1.77	1.68	3.33	3.10	2.18	2.08	4.19	3.94
Bumper CW Side (B3)	1.53	1.46	3.06	2.87	1.77	1.68	3.33	3.10	2.18	2.08	4.19	3.94
Cushion/Flow Both Sides (C1) (Q1)	N/A	N/A	N/A	N/A	1.63	1.68	3.58	3.10	2.03	2.08	4.51	3.94
Cushion/Flow CCW Side (C2) (Q2)	N/A	N/A	N/A	N/A	1.63	1.68	3.58	3.10	2.03	2.08	4.51	3.94
Cushion/Flow CW Side (C3) (Q3)	N/A	N/A	N/A	N/A	1.63	1.68	3.58	3.10	2.03	2.08	4.51	3.94
Angle Adjustment Both Sides (A1)	1.41	1.46	3.05	2.87	1.63	1.68	3.27	3.10	2.03	2.08	4.28	3.94
Angle Adjustment CCW Side (A2)	1.41	1.46	3.05	2.87	1.63	1.68	3.27	3.10	2.03	2.08	4.28	3.94
Angle Adjustment CW Side (A3)	1.41	1.46	3.05	2.87	1.63	1.68	3.27	3.10	2.03	2.08	4.28	3.94

\*\*Select Magnetic Position Sensing adder from MRS table

	1-1/2" (196)				2" (494)			
	P1	P2	L1	L2	P1	P2	L1	L2
Degrees of Full Rotation	full rot.	full rot.	full rot.	full rot.	full rot.	full rot.	full rot.	full rot.
Adder per degree of rotation	0.0097	0.0097	0.0097	0.0097	0.0137	0.0137	0.0137	0.0137
Degree of Stop Rotation	stop rot.	stop rot.	stop rot.	stop rot.	stop rot.	stop rot.	stop rot.	stop rot.
Adder per degree of rotation	N/A	N/A	0.0097	0.0097	N/A	N/A	0.0137	0.0137
Base Unit (No Option)	2.28	2.33	4.39	4.44	2.81	2.86	5.13	5.18
Bumpers Both Sides (B1)	2.43	2.33	4.69	4.44	3.01	2.86	5.53	5.18
Bumper CCW Side (B2)	2.43	2.33	4.69	4.44	3.01	2.86	5.53	5.18
Bumper CW Side (B3)	2.43	2.33	4.69	4.44	3.01	2.86	5.53	5.18
Cushion/Flow Both Sides (C1) (Q1)	2.28	2.33	5.03	4.44	2.81	2.86	5.95	5.18
Cushion/Flow CCW Side (C2) (Q2)	2.28	2.33	5.03	4.44	2.81	2.86	5.95	5.18
Cushion/Flow CW Side (C3) (Q3)	2.28	2.33	5.03	4.44	2.81	2.86	5.95	5.18
Angle Adjustment Both Sides (A1)	2.28	2.33	4.80	4.44	2.81	2.86	5.66	5.18
Angle Adjustment CCW Side (A2)	2.28	2.33	4.80	4.44	2.81	2.86	5.66	5.18
Angle Adjustment CW Side (A3)	2.28	2.33	4.80	4.44	2.81	2.86	5.66	5.18

**Note:**

Overall length calculator spreadsheet available. Contact the Technical Assistance Center for details.

\*\*Select Magnetic Position Sensing adder from MRS table

Double rack overall width calculation: PT-196180/045-8C1--Using the chart above, calculate L1 and L2 dimensions as follows:

L1 = Total rotation (180) \* (.0097) Full rotation adder + Largest Degrees stop (135) \* (.0097) stop rotation adder + Cushion adder (5.03")

L2 = Total rotation (180) \* (.0097) Full rotation adder + Largest Degrees stop (135) \* (.0097) stop rotation adder + Cushion adder (4.44")

[L1 = (1.746" + 1.310" + 5.03") = 8.086"] + [L2 = (1.746" + 1.310" + 4.44") = 7.496"]; Total width = 8.086" + 7.496" = 15.58"

\*\*Notes - Largest stop rotation is used for double rack models to calculate overall L1 and L2 length. Double rack models - one body on each side will be shorter if the shaft mid-position is not 1/2 of the total rotation, the above calculation still provides the units overall width.

# Bimba Pneu-Turn Rotary Actuators

## Engineering Specifications

### ACTUATOR OPERATION

Rotary action of the Pneu-Turn Rotary Actuator is achieved through the use of a rack and pinion assembly. Just as with a pneumatic or hydraulic cylinder, the speed of rotation may be controlled through the use of flow controls. The action at the end of the rotation can be controlled by the use of adjustable cushions, which are available as an option.

Care should be taken to insure that the inertial force does not exceed the published torque capacity. An external stop may be necessary to avoid exceeding the torque capacity due to inertial loads.

When mounting the Pneu-Turn against the shaft side of the housing, be sure to provide clearance for the pilot diameter to avoid excessive bearing pressure.

For standard models, axial loads must only be applied in the direction indicated on the dimensional drawings. The Dual Shaft or Rear Shaft options can be used to correctly orient tension induced axial loads. With the Ball Bearing option, axial loads can be applied in either direction.

The Angle Adjustment Option will allow 45° of adjustability. If cushions are ordered in conjunction with the angle adjustment option, adjustability will be 10°.

### PORT POSITIONING

Ports on the Pneu-Turn may be repositioned to accommodate any air line configuration by loosening the three body retainer screws. Once desired port positions are obtained, tighten screws to specified torque values.

### LUBRICATION

The Pneu-Turn Rotary Actuator is pre-lubricated at the factory for extensive, maintenance-free operation. The life of the rotary actuator can be lengthened by providing additional lubrication with an air line mist lubricator or direct introduction of oil to the actuator every 500 hours of operation. Recommended oils for Buna N seals are medium

to heavy inhibited hydraulic and general purpose oil. If High Temperature seals, use Dow Corning #710. Other types of pre-lube are available upon request.

The rack and pinion gear and ball bearings are pre-lubricated at the factory for extensive, maintenance-free operation. If additional lubrication should be required, use a high grade bearing grease.

### WOODRUFF KEY LOCATION

The standard position of the woodruff key is 12 o'clock at the center of rotation. For Three-Position Pneu-Turn, the center position is 12 o'clock, ± 2°.

### RATINGS:

**Pressure Rating:** All Bimba Pneu-Turn Rotary Actuators are rated for 150 PSI air.

**Rotation Tolerance:** Standard rotation tolerance for 9/16" – 3/4" bore is -0° to 15° and for 1-1/16" – 2" bore is -0° to +10°. Bumper option allows compression under pressure which may exceed tolerance. If higher accuracy desired, please specify angle adjustment.

**Temperature Range:** Buna N: (Standard) - 20°F to +200°F; Option (V) High Temperature seals: 0°F to +400°F. Temperature range of high temperature seals with Ball Bearing option is 0°F to +250°F. If cylinders are operated at temperatures below 0° for extended time periods, special modifications may be required. Special seal materials are available on request.

### Backlash:

- Without "X" option, 1-1/2° of Arc Maximum. Double rack actuators have zero backlash at end of rotational stroke
- With "X" option, single rack models have zero mid-rotational and end of rotation backlash. Double rack models have zero mid-rotational backlash.

**Breakaway:** Less than 5 PSI.

### Standard Line

Series	9/16"		3/4"		1-1/16"		1-1/2"		2"	
	(006)	(014)	(017)	(033)	(037)	(074)	(098)	(196)	(247)	(494)
Theoretical Torque Capacity (in.-lbs./PSI)	0.068	0.135	0.166	0.331	0.369	0.739	0.982	1.963	2.468	4.935
Bearing Load (Axial) (lbs.)	25	25	25	25	40	40	40	40	80	80
Bearing Load (Radial) (lbs.)	200	200	250	250	300	300	350	350	500	500
Distance Between Bearing Midpoints (in.)	0.77	0.77	0.96	0.96	1.24	1.24	1.70	1.70	1.98	1.98
Maximum Rate of Rotation (@ 100 PSI With No Load)	3000 deg./sec.	3000 deg./sec.	3500 deg./sec.	3500 deg./sec.	2000 deg./sec.	2000 deg./sec.	1500 deg./sec.	1500 deg./sec.	1000 deg./sec.	1000 deg./sec.
Weight (Approximate) (oz.)	6	11.5	11	20.5	21	38	48	89	105	152
Body Retainer Cap Screw Recommended Tightening Torque (in.-lbs.)	10	10	12	12	12	12	20	20	20	20

### For Ball Bearing Option, the Following Specifications Apply

Series	9/16"		3/4"		1-1/16"		1-1/2"		2"	
	(006)	(014)	(017)	(033)	(037)	(074)	(098)	(196)	(247)	(494)
Bearing Load (Axial) (lbs.)	55	55	75	75	100	100	110	110	130	130
Bearing Load (Radial) (lbs.)	205	205	270	270	380	380	425	425	740	740
Distance Between Bearing Midpoints (in.)	.72	.72	.96	.96	1.26	1.26	1.71	1.71	1.82	1.82
Weight (Approximate) (oz.)	6	11.5	10.5	20	20.5	37.5	47	88	103	150

# Bimba Pneu-Turn Rotary Actuators

## Engineering Specifications

### Kinetic Energy Capacity

A load connected to the shaft of a Pneu-Turn will produce kinetic energy as it is rotated. This kinetic energy must be absorbed by the Pneu-Turn or other stopping device. If the Pneu-Turn is to stop the load without external devices, then the application kinetic energy must not exceed the maximums noted in the table below.

### Maximum Allowable Kinetic Energy (in.-lbs.)

Size	Without Cushions	With Cushions
9/16" (006 / 014)	0.02	N/A
3/4" (017 / 033)	0.04	0.08
1-1/16" (037 / 074)	0.07	0.88
1-1/2" (098 / 196)	0.41	7.80
2" (247 / 494)	1.60	13.00

The kinetic energy developed by your application can be determined by using the equations noted below:

$$KE = 0.5 * I * w^2$$

$$w = 1.20 * (\phi / t)$$

#### LEGEND:

KE = Kinetic energy (in.-lbs.)

I = Moment of inertia (in.-lb.-sec.<sup>2</sup>)

w = Rotational speed (radians/sec.)

$\phi$  = Angle of rotation (radians)

t = Time of rotation (sec.)

W = Weight of load (lb.)

g = Acceleration of gravity (386 in./sec.<sup>2</sup>)

Below are examples of attachments, their geometry, and the equation to use to determine the Moment of Inertia.

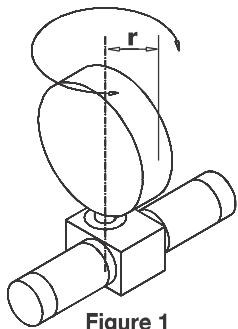

Thin Disc  
(mounted on side  
through center)

$$I = \frac{W}{g} * \frac{r^2}{4}$$

Figure 1

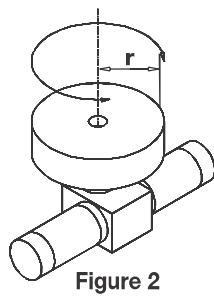

Thin Disc  
(centered)

$$I = \frac{W}{g} * \frac{r^2}{2}$$

Figure 2

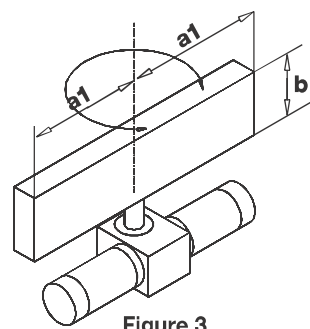

Thin Rectangular  
Plate  
(centered and  
mounted on side)

$$I = \frac{W}{g} * \frac{(2(a1))^2}{12}$$

Figure 3

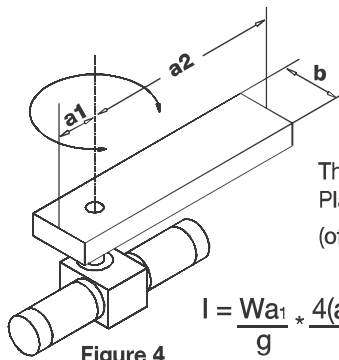

Thin Rectangular  
Plate  
(off-centered)

$$I = \frac{W a_1}{g} * \frac{4(a1)^2 + b^2}{12} + \frac{W a_2}{g} * \frac{4(a2)^2 + b^2}{12}$$

Figure 4

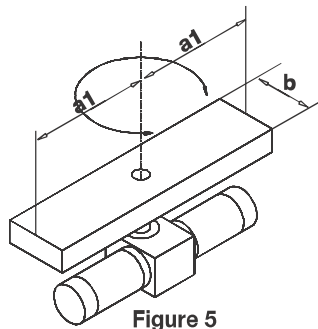

Thin Rectangular  
Plate  
(centered)

$$I = \frac{W}{g} * \frac{(2(a1))^2 + b^2}{12}$$

Figure 5

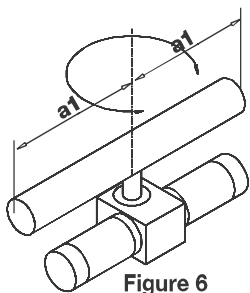

Slender Rod  
(centered)

$$I = \frac{W}{g} * \frac{(2(a1))^2}{12}$$

Figure 6

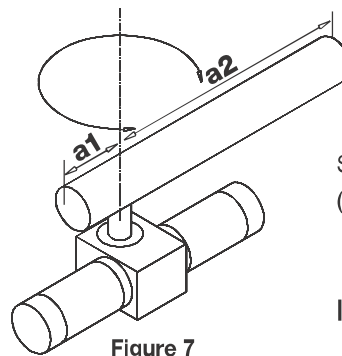

Slender Rod  
(off-centered)

$$I = \frac{W a_1}{g} * \frac{a1^2}{3} + \frac{W a_2}{g} * \frac{a2^2}{3}$$

Figure 7

# Bimba Pneu-Turn Rotary Actuators

## Application Possibilities

Picture the possibilities. Consider the many benefits of using the Bimba Pneu-Turn Rotary Actuator:

- Compact, Space-Saving Design
- Lightweight
- Corrosion Resistant Components
- Low Cost

Now, using the pictures on this page as a springboard, you can understand that the applications are limitless.

All you need is your imagination and a Bimba Pneu-Turn Rotary Actuator.

**Transferring**

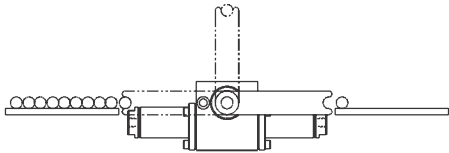

**Camming**

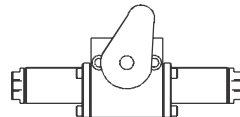

**Bending (Tube or Wire)**

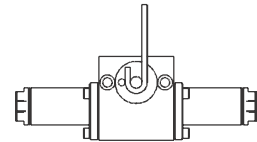

**Indexing**

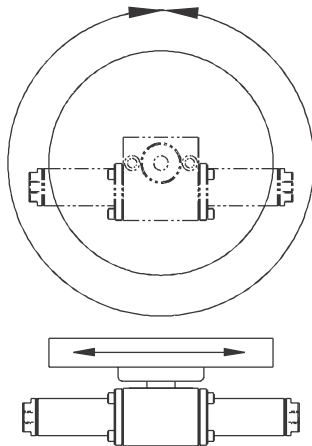

**Unloading**

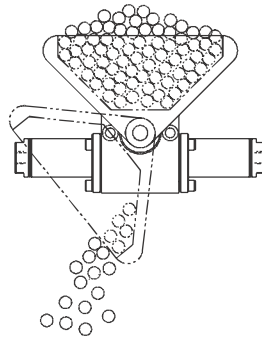

**Opening/Closing**

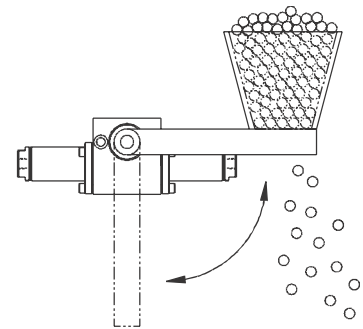

**Turning**

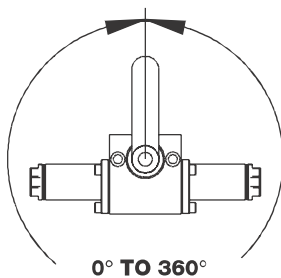

**Clamping**

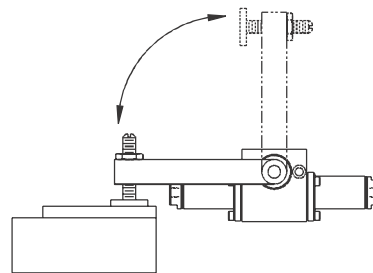

**Mix/Agitate**

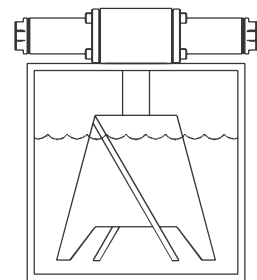

**Screw/Clamping**

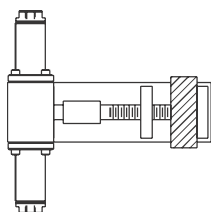

**Feeding**

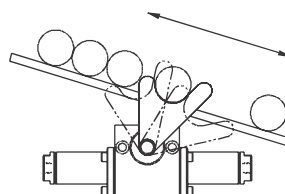

**Valve Actuator**

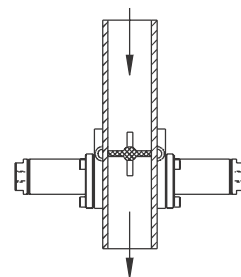

# Bimba Pneu-Turn Rotary Actuators Checklist

## Pneu-Turn Application Checklist

This checklist makes sizing and selecting Bimba actuators easier. Bimba's Engineering Department will assist you by providing a detailed analysis of your application and, based on the information in the application checklist, will help you choose the actuators best suited to your needs.

**Step 1. Photocopy the sketch and checklist sheets.**

**Step 2. Complete the sketch and checklist.**

**Step 3. Mail or fax the sketch and checklist to your local stocking distributor.**

**Date:** \_\_\_\_\_

**Your Name:** \_\_\_\_\_

**Company:** \_\_\_\_\_

**Address:** \_\_\_\_\_

**Phone:** \_\_\_\_\_

**Fax:** \_\_\_\_\_

**Request Pneu-Turn model number recommended by Engineering?** Yes \_\_\_\_\_ No \_\_\_\_\_

**If no, Pneu-Turn model number to be used in your application:** \_\_\_\_\_

Air \_\_\_\_\_ psi Hydraulic \_\_\_\_\_ psi

**Torque Required:**

0 – 15 in-lbs. 75 – 100 in-lbs.

15 – 35 in-lbs. 200 – 500 in-lbs.

35 – 75 in-lbs. other: \_\_\_\_\_

**Application closest to (circle one):**

Fig. 1 Fig. 2 Fig. 3 Fig. 4 Fig. 5 Fig. 6 Fig. 7

**Dimensions applicable to your lever arm:**

Radius \_\_\_\_\_ in. A1 \_\_\_\_\_ in.

A2 \_\_\_\_\_ in. B \_\_\_\_\_ in.

**Weight and material of lever arm and attachments:**

\_\_\_\_\_ lbs. \_\_\_\_\_ oz. material: \_\_\_\_\_

**Load to be moved by the lever arm:**

\_\_\_\_\_ lbs. \_\_\_\_\_ oz.

**Distance from the center of the load to the center of the shaft:** \_\_\_\_\_ in.

**Shaft Mounted: (shaft, cylinders)**

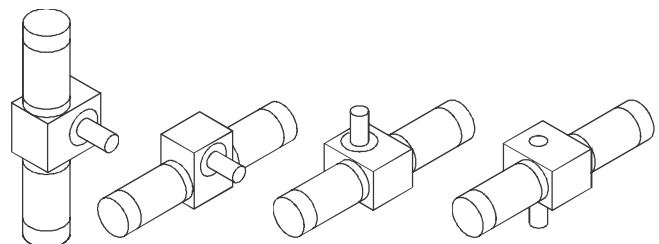

(horiz., vert.) (horiz., horiz.) (vert. (up), horiz.) (vert. (down) horiz.)

**Axial loading?** Yes \_\_\_\_\_ No \_\_\_\_\_

If yes, direction with reference to pushing or pulling the standard shaft: \_\_\_\_\_

**Rotation of lever arm:** \_\_\_\_\_ degrees

**Time needed to move load in one direction:**

\_\_\_\_\_ secs. Opposite direction \_\_\_\_\_ secs.

**May cushions be used to slow the load at the end of stroke?**

Yes \_\_\_\_\_ No \_\_\_\_\_

**May external stops be used if deemed necessary?**

Yes \_\_\_\_\_ No \_\_\_\_\_

