



Pneumatic components

# Safety precautions

Always read this section before starting use.

Refer to Intro 71 for general precautions of the cylinder, and to Intro 78 for general precautions of the cylinder switch.

## Shuttle mover SM Series

### Design & Selection

#### ⚠ WARNING

- This product must not be used submerged in water, oil or powder, or where coolant, coolant fluid or swarf, etc., may come in contact.
- Always incorporate an interlock in the control circuit for carrier movement to ensure safety.
- Applications in which the carrier is fixed and the rail section is used as the moving object are not possible.
- Make sure that the cylinder tube and rail will not be damaged by accidentally dropping workpieces. Not doing so could cause malfunctions.

#### ⚠ CAUTION

- Confirm that the sectional area of the pipe connecting the cylinder and direction control valve is adequate for achieving the specified piston speed.

- The leg installation pitch should be an interval of two meters.

- Provide the following space near the end unit.

- Sufficient space to remove the workpiece
- Sufficient space to adjust the carrier stroke end  $\pm 10\text{mm}$
- Sufficient space to move when adjusting the tube piping connected to the end piping connection port  $\pm 10\text{mm}$ , and space to adjust the speed controller
- Sufficient space to remove the end rail related parts when servicing the piston

### Installation & Adjustment

#### ⚠ WARNING

- If this product intersects passageways or workers' work areas, always provide a safety cover at areas where a human hand can enter as protection from movement areas and dropping.
- Do not move this product by hitting it with a hammer, or directly suspend it with a wire rope, etc.
- Immediately after installing this product (before supplying the air) directly move the carrier by hand and check for interfering objects in the movement area.
- The stroke end is adjusted  $\pm 10\text{mm}$  by sliding the entire end block. If adjusted by the amount that the stopper bolt and shock absorber are screwed in, the magnetic connection of the carrier and piston will deviate.

#### ⚠ CAUTION

- The connection port block is slid to adjust the stroke end by  $\pm 10\text{mm}$ . Use nylon or urethane tubing for this connection, and provide sufficient allowance in the length. A  $\phi 12 \times \phi 8\text{mm}$  tube should be used.
- If the rail is twisted, bent or pulled when the legs are installed, air could leak from the joint section. Do not apply excessive force.
- Make sure that foreign matter such as drill chips generated during the installation do not enter the cylinder tube during installation and assembly.

SCP\*2  
CMK2  
CMA2  
SCM  
SCG  
SCA2  
SCS  
CKV2  
CA/OV2  
SSD  
CAT  
MDC2  
MVC  
SMD2  
MSD\*  
FC\*  
STK  
ULK\*  
JSK/M2  
JSG  
JSC3  
USSD  
USC  
JSB3  
LMB  
STG  
STS/L  
LCS  
LCG  
LCM  
LCT  
LCY  
STR2  
UCA2  
HCM  
HCA  
SRL2  
SRG  
SRM  
SRT  
MRL2  
MRG2  
SM-25  
CAC3  
UCAC  
RCC2  
MFC  
SHC  
GLC  
Ending

## During Use & Maintenance

### ⚠ WARNING

- The most suitable ambient temperature range for using the cylinder is 5 to 40°C. Avoid use at temperatures exceeding 40°C as damage or operation faults, etc., could result.

If the temperature drops below 5°C, the water in the circuit could freeze and cause damage or operation faults, so always provide means to prevent freezing.

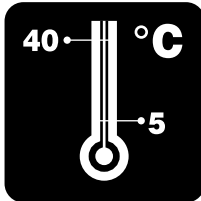

- The shuttle mover is a magnetic rod-less cylinder. A magnetic is incorporated, so keep away products affected by magnets (magnetic disks, magnetic cards, magnetic tape, testers, etc.).
- The magnetic connection of the carrier and piston could deviate if an external force exceeding the magnetic holding force is applied.
- Operation faults could result if foreign matter gets caught between the carrier and rail.
- Grease is applied inside the cylinder tube. Make sure that foreign matter such as swarf does not get in during assembly or disassembly work.

### ⚠ CAUTION

- If the oil is spent and operation becomes unstable, remove the piston and grease it. Refer to the instruction manual for details on greasing.

The periodic greasing should be carried out after 2,000km of travel.

- When using in a place where the rail, etc., could become dirty, the cylinder must be periodically cleaned to improve the guide roller rotation.

SCP*2
CMK2
CMA2
SCM
SCG
SCA2
SCS
CKV2
CA/OV2
SSD
CAT
MDC2
MVC
SMD2
MSD*
FC*
STK
ULK*
JSK/M2
JSG
JSC3
USSD
USC
JSB3
LMB
STG
STS/L
LCS
LCG
LCM
LCT
LCY
STR2
UCA2
HCM
HCA
SRL2
SRG
SRM
SRT
MRL2
MRG2
<b>SM-25</b>
CAC3
UCAC
RCC2
MFC
SHC
GLC
Ending

Shuttle mover  
Rodless type

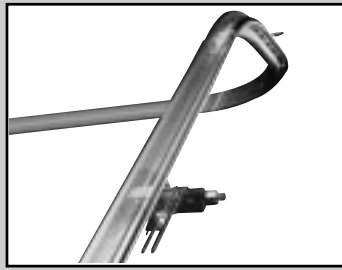

Shuttle mover standard type/high load type

# SM-25 series

Air-driven three-dimensional transfer P&P system enabling a free layout



## Specifications

Model no.	Standard type	High load type
Descriptions		
Working fluid	Compressed air	
Working pressure MPa	0.3 to 0.6	
Ambient temperature °C	5 to 40	
Bore size mm	φ 25	
Port size	Rc3/8	
Magnetic force holding force N	120	240
Max. allowable load weight kg	2 (installed full load weight)	4 (installed full load weight)
Max. transfer distance m	20	
Stroke limit adjustment length mm	± 10	
Cushion	Piston	Rubber cushion
	Carrier	Shock absorber
Lubrication	Not required (when lubricating, use turbine oil Class 1 ISO VG32)	

## Weight

Model	Weight (kg)	
	Standard type	High load type
Carrier	1	1.7
Rail end	2 x 2 pieces	3.6 x 2 pieces
Horizontal curve unit 90°	4	Same as left
Horizontal curve unit 45°	2.4	
Vertical (inside) curve unit 90°	3	Same as left
Vertical (inside) curve unit 45°	1.8	
Vertical (out) curve unit 90°	3	
Vertical (out) curve unit 45°	1.8	
Air supply unit (nozzle 2 or 3 pcs.)	0.3 (end installation) x 2 pieces	0.4 (end installation) x 2 pieces
	0.2 (carrier installation) x 2 pieces	0.4 (carrier installation) x 2 pieces
Air supply unit (nozzle 4 pcs.)	1.6 (end installation) x 2 pieces	Same as left
	0.3 (carrier installation) x 1 piece	
Joint	0.3	0.4
Straight unit	0.4	Same as left
	0.8	
	to	
	8	
	* Add 0.4 per 100mm stroke	

## How to order

**SM-25-ST-H 100**

A Model no.		Descriptions
Standard type	High load type	
CA	CA-H	Carrier
RE Note 1	RE-H Note 1	Rail end
ST	ST-H	Straight unit Note 2
SC90	SC-H90	Horizontal curve unit 90°
SC45	SC-H45	Horizontal curve unit 45°
VC90-IN	VC-H90-IN	Vertical (inside) curve unit 90°
VC45-IN	VC-H45-IN	Vertical (inside) curve unit 45°
VC90-OUT	VC-H90-OUT	Vertical (out) curve unit 90°
VC45-OUT	VC-H45-OUT	Vertical (out) curve unit 45°
PP Note 3	PP-H Note 4	Air supply unit
PR Note 5	PR-H Note 5	Air supply unit
RJ	RJ-H	Joint

B Stroke length (mm)	Note 2
100 to 2000	Note 6

- Note 1: 1 set (2 pcs.) joint and surge suppressor enclosed.
  - Note 2: The stroke must be indicated only for the straight unit.
  - Note 3: For two nozzles.  
One set includes the 2 types for rail end and 2 types for carrier.
  - Note 4: For three nozzles.  
One set includes the 2 types for rail end and 2 types for carrier.
  - Note 5: For four nozzles.  
One set includes the 2 types for rail end and 1 type for carrier.
  - Note 6: Max. stroke length is 2000mm.  
10mm strokes are standard for 100 to 190, and 100mm stroke is standard for 200 to 2000.  
Strokes of 1mm increments are available as custom orders.
  - Note 7: One joint is enclosed with each rail unit.
- The SKH series shock-less valve is recommended for the valve. Refer to the "General Pneumatic Components (No. CB-023SA)" for details on the valve.

SCP\*2  
CMK2  
CMA2  
SCM  
SCG  
SCA2  
SCS  
CKV2  
CA/OV2  
SSD  
CAT  
MDC2  
MVC  
SMD2  
MSD\*  
FC\*  
STK  
ULK\*  
JSK/M2  
JSG  
JSC3  
USSD  
USC  
JSB3  
LMB  
STG  
STS/L  
LCS  
LCG  
LCM  
LCT  
LCY  
STR2  
UCA2  
HCM  
HCA  
SRL2  
SRG  
SRM  
SRT  
MRL2  
MRG2  
SM-25  
CAC3  
UCAC  
RCC2  
MFC  
SHC  
GLC  
Ending

### Internal structure and parts list $\phi 25$

● Carrier (CA)

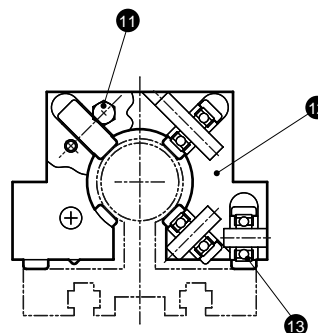
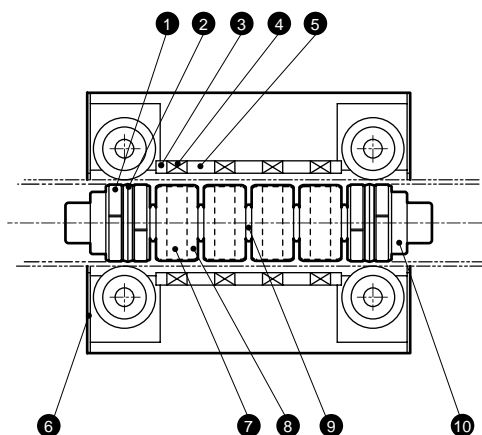

● Carrier/high load type (CA-H)

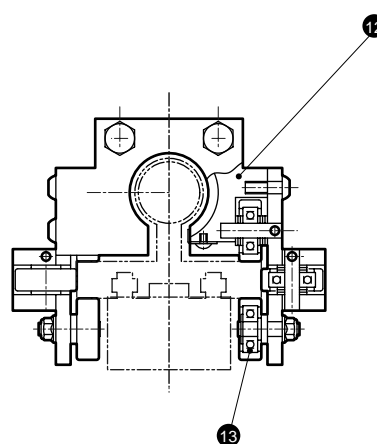
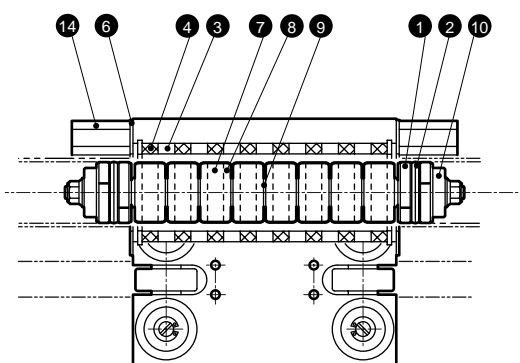

### Parts list

No.	Parts name	Material	Remarks	No.	Parts name	Material	Remarks
1	Wear ring	Acetar resin		8	Internal and yoke	Steel	
2	Piston packing seal	Nitrile rubber		9	Flexible shaft	Nylon	
3	External and out yoke	Steel		10	Piston	Aluminum alloy	
4	External and magnet	Rear-earth magnets		11	Stop pin	Steel	
5	External and inside yoke	Steel		12	Housing	Aluminum alloy	
6	Side cover	Stainless steel		13	Roller	Polyurethane rubber	
7	Internal and magnet	Rear-earth magnets		14	Stopper bolt	Steel	

### Repair parts list

Parts name	Series	Set No.	Repair parts number
Piston set	Standard type	SM-25-CA-PS	1 2 7 8 9 10
	High load type	SM-25H-CA-PS	
Carrier set	Standard type	SM-25-CA-S	3 4 5 6 11 12 13
	High load type	SM-25H-CA-S	3 4 6 12 13 14
Packing seal set (Note 1)	Standard type	SM-25-CA-PK	1 2
	High load type		

Note 1: One set contains four wear rings and two piston packing pieces.

SCP\*2  
CMK2  
CMA2  
SCM  
SCG  
SCA2  
SCS  
CKV2  
CA/OV2  
SSD  
CAT  
MDC2  
MVC  
SMD2  
MSD\*  
FC\*  
STK  
ULK\*  
JSK/M2  
JSG  
JSC3  
USSD  
USC  
JSB3  
LMB  
STG  
STS/L  
LCS  
LCG  
LCM  
LCT  
LCY  
STR2  
UCA2  
HCM  
HCA  
SRL2  
SRG  
SRM  
SRT  
MRL2  
MRG2  
SM-25  
CAC3  
UCAC  
RCC2  
MFC  
SHC  
GLC  
Ending

Shuttle mover  
Rodless type

## Internal structure and parts list

### ● Rail end (RE)

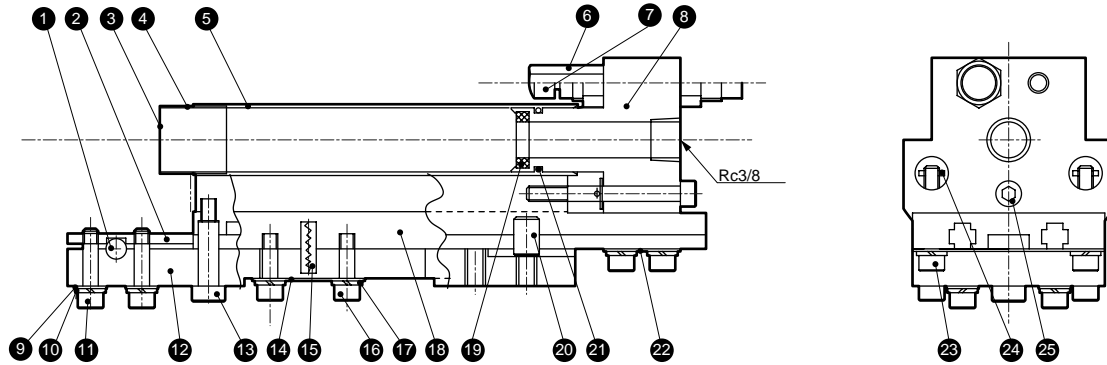

### ● Rail end/high load type (RE-H)

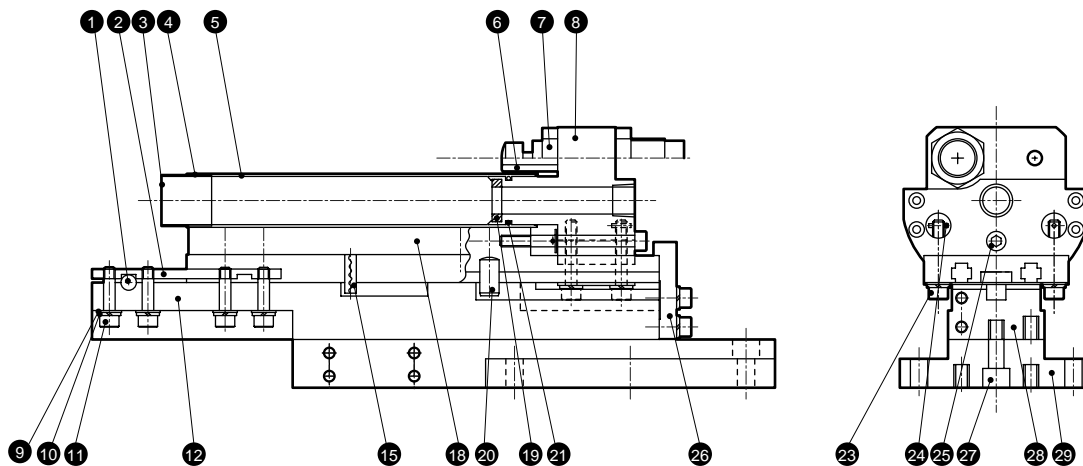

### Parts list

No.	Parts name	Material	Remarks	No.	Parts name	Material	Remarks
1	Dowel pin	Stainless steel		16	Hexagon socket head cap bolt	Steel	
2	Plate nut	Steel		17	Spring washer	Steel	
3	Joint sleeve	Stainless steel		18	End rail	Aluminum alloy	
4	Tube packing seal	Nitrile rubber		19	Cushion rubber	Synthetic rubber	
5	End pipe	Stainless steel		20	Pin	Steel	
6	Stopper bolt	Steel		21	O ring	Nitrile rubber	
7	Shock absorber (note)			22	Stopper washer	Stainless steel	
8	End block	Aluminum alloy		23	Safety bolt	Steel	
9	Plain washer	Steel		24	Spring pin	Stainless steel	
10	Spring washer	Steel		25	Adjusting bolt	Steel	
11	Hexagon socket head cap bolt	Steel		26	Holder	Steel	
12	Joint plate	Aluminum alloy		27	Hexagon socket head cap bolt	Steel	
13	Shoulder bolt	Steel		28	Joint plate	Aluminum alloy	
14	Fixing washer	Stainless steel		29	End bracket	Aluminum alloy	
15	Spring pin	Stainless steel					

Note: ⑦ Shock absorber standard type NCK-00-2.6-C  
high load type NCK-00-7-C

SCP\*2  
CMK2  
CMA2  
SCM  
SCG  
SCA2  
SCS  
CKV2  
CA/OV2  
SSD  
CAT  
MDC2  
MVC  
SMD2  
MSD\*  
FC\*  
STK  
ULK\*  
JSK/M2  
JSG  
JSC3  
USSD  
USC  
JSB3  
LMB  
STG  
STS/L  
LCS  
LCG  
LCM  
LCT  
LCY  
STR2  
UCA2  
HCM  
HCA  
SRL2  
SRG  
SRM  
SRT  
MRL2  
MRG2  
SM-25  
CAC3  
UCAC  
RCC2  
MFC  
SHC  
GLC  
Ending

### Internal structure and parts list $\phi$ 25

#### ● Joint (RJ)

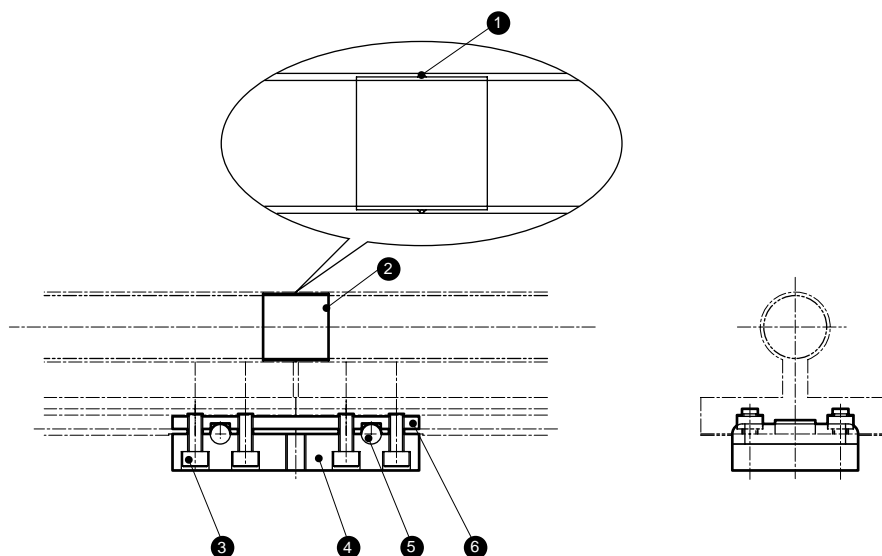

#### ● Joint/high load type (RJ-H)

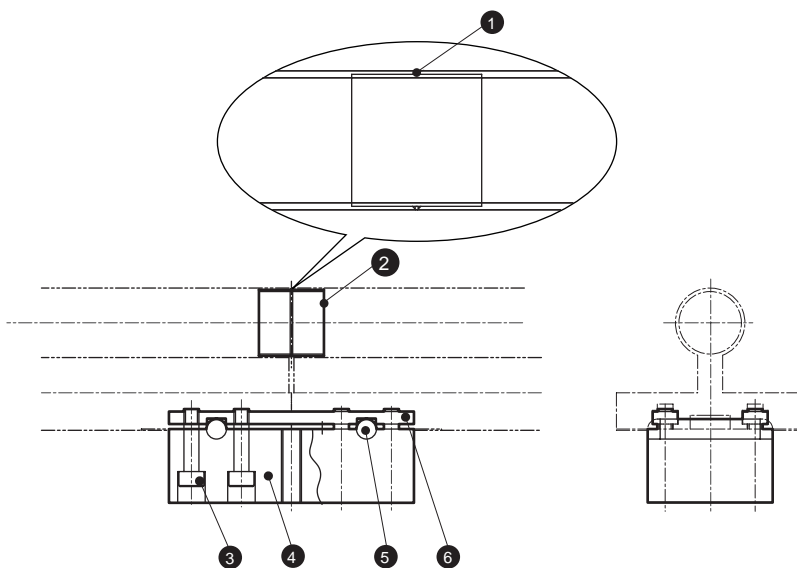

### Parts list

No.	Parts name	Material	Remarks	No.	Parts name	Material	Remarks
1	Tube packing seal	Nitrile rubber		4	Joint plate	Aluminum alloy	
2	Joint sleeve	Stainless steel		5	Dowel pin	Stainless steel	
3	Hexagon socket head cap bolt	Steel		6	Connection nut	Steel	

### Repair parts list

Parts name	Set No.	Repair parts number
Gasket set (note)	SM-25-RJ-GS	1
Grease	SM-25-GR	Circle attached SL-F No.1 50g

Note: One set contains ten gaskets.

SCP\*2  
CMK2  
CMA2  
SCM  
SCG  
SCA2  
SCS  
CKV2  
CA/OV2  
SSD  
CAT  
MDC2  
MVC  
SMD2  
MSD\*  
FC\*  
STK  
ULK\*  
JSK/M2  
JSG  
JSC3  
USSD  
USC  
JSB3  
LMB  
STG  
STS/L  
LCS  
LCG  
LCM  
LCT  
LCY  
STR2  
UCA2  
HCM  
HCA  
SRL2  
SRG  
SRM  
SRT  
MRL2  
MRG2  
SM-25  
CAC3  
UCAC  
RCC2  
MFC  
SHC  
GLC

Shuttle mover  
Rodless type

## Internal structure and parts list $\phi$ 25

### ● Air supply unit (PP)

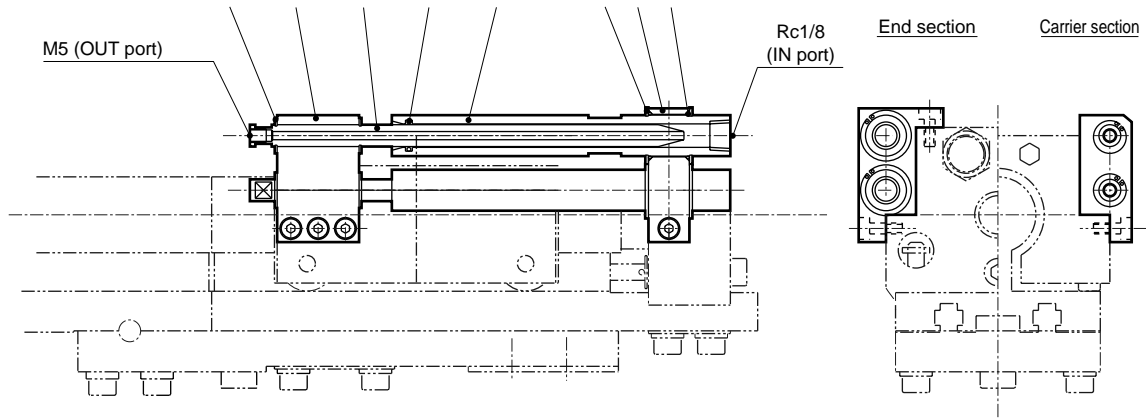

### ● Air supply unit/high load type (PP-H)

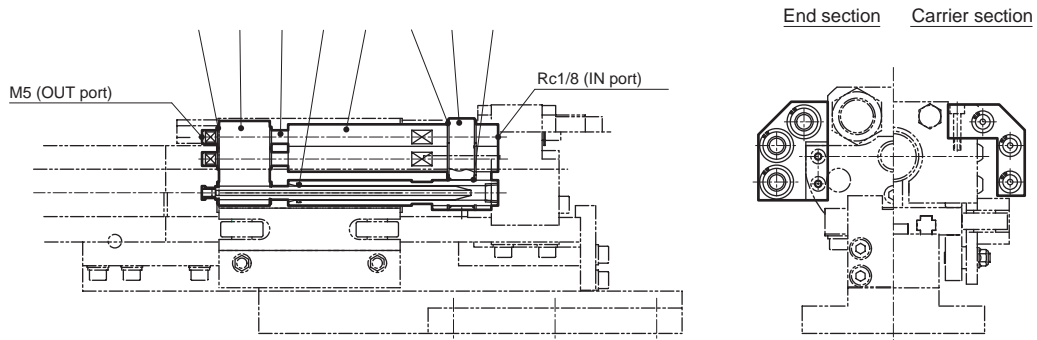

### Parts list

No.	Parts name	Material	Remarks	No.	Parts name	Material	Remarks
1	C type snap ring	Steel		5	Fixing nozzle	Steel	
2	Nozzle holder	Aluminum alloy		6	C type snap ring	Steel	
3	Nozzle	Steel		7	Fixing holder	Steel	
4	O ring	Nitrile rubber		8	O ring	Nitrile rubber	

### Internal structure and parts list $\phi 25$

● Air supply unit (PR)

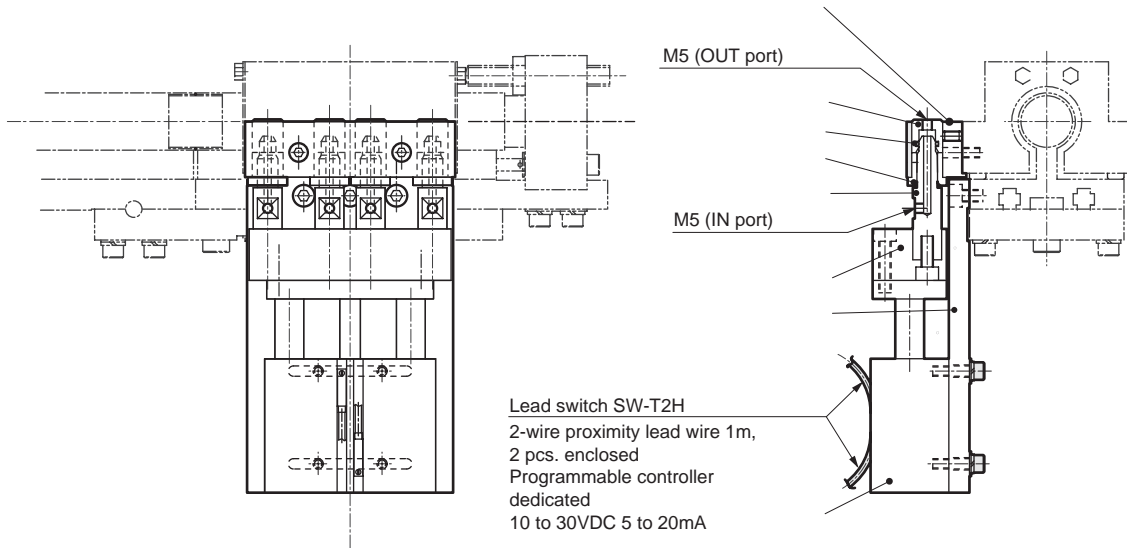

● Air supply unit/high load type (PR-H)

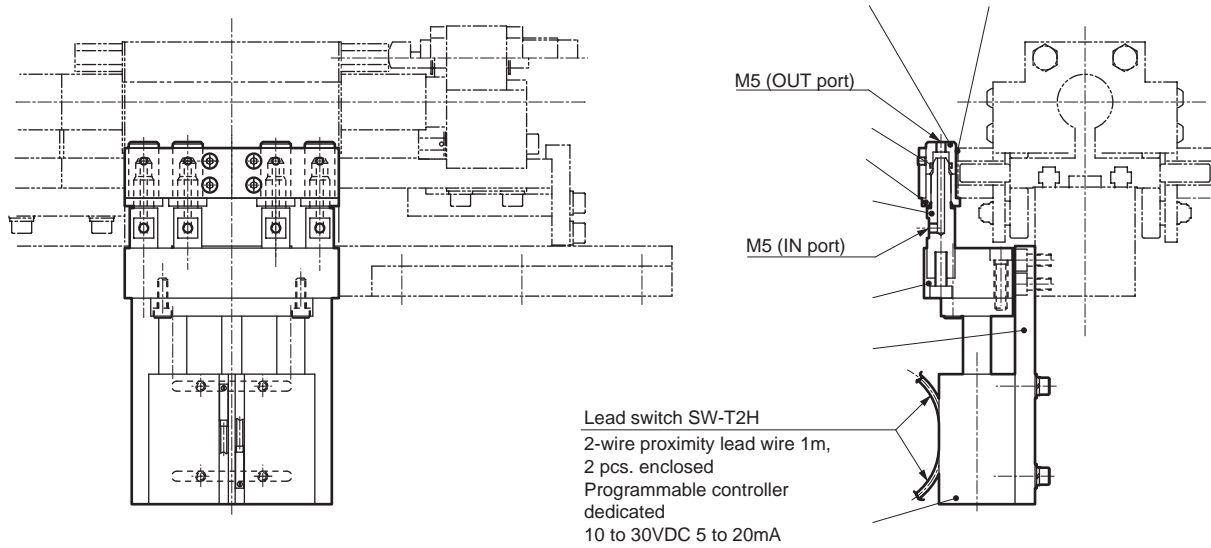

### Parts list

No.	Parts name	Material	Remarks	No.	Parts name	Material	Remarks
1	Push holder	Aluminum alloy		6	Pin holder	Aluminum alloy	
2	Bush	Brass		7	Mounting plate	Aluminum alloy	
3	O ring	Nitrile rubber		8	Air cylinder	STS-M-20-25	
4	Positioning bush	Steel		9	Reed switch	SW-T2H	
5	Pin	Steel					

SCP*2
CMK2
CMA2
SCM
SCG
SCA2
SCS
CKV2
CA/OV2
SSD
CAT
MDC2
MVC
SMD2
MSD*
FC*
STK
ULK*
JSK/M2
JSG
JSC3
USSD
USC
JSB3
LMB
STG
STS/L
LCS
LCG
LCM
LCT
LCY
STR2
UCA2
HCM
HCA
SRL2
SRG
SRM
SRT
MRL2
MRG2
<b>SM-25</b>
CAC3
UCAC
RCC2
MFC
SHC
GLC

Ending

Shuttle mover  
Rodless type



# SM-25 Series

## Dimensions

SCP*2
CMK2
CMA2
SCM
SCG
SCA2
SCS
CKV2
CA/OV2
SSD
CAT
MDC2
MVC
SMD2
MSD*
FC*
STK
ULK*
JSK/M2
JSG
JSC3
USSD
USC
JSB3
LMB
STG
STS/L
LCS
LCG
LCM
LCT
LCY
STR2
UCA2
HCM
HCA
SRL2
SRG
SRM
SRT
MRL2
MRG2
<b>SM-25</b>
CAC3
UCAC
RCC2
MFC
SHC
GLC
Ending

### ● Carrier (CA)

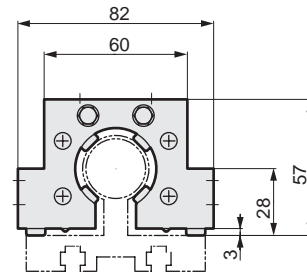
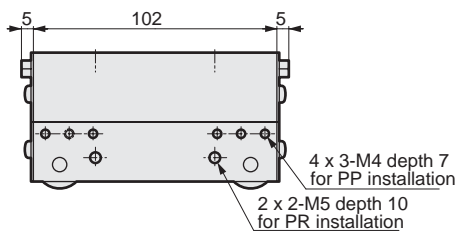
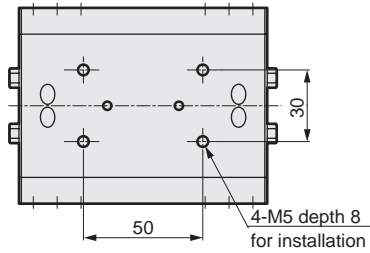

### ● Carrier/high load type (CA-H)

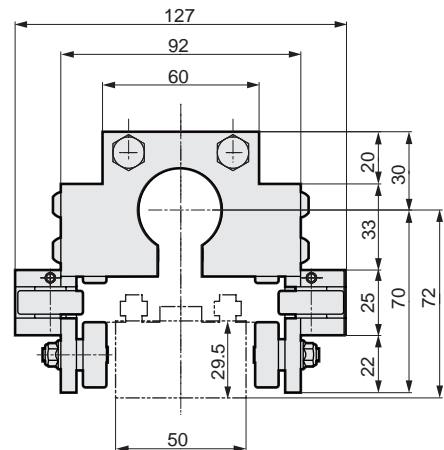
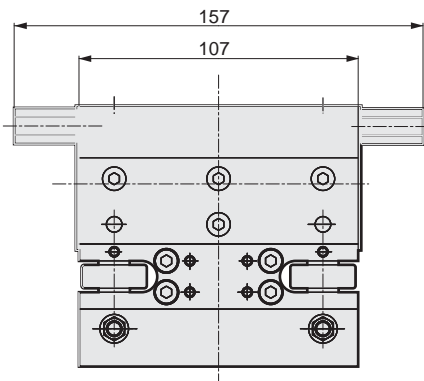
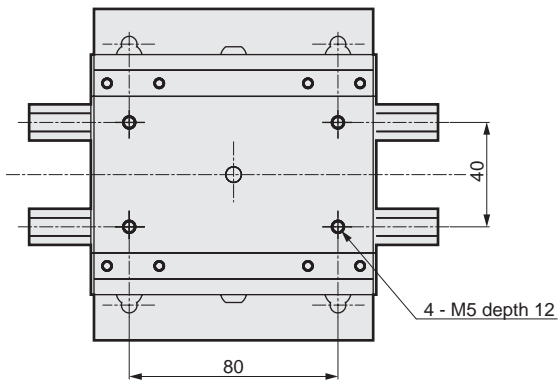

### Dimensions

#### ● Rail end (RE)

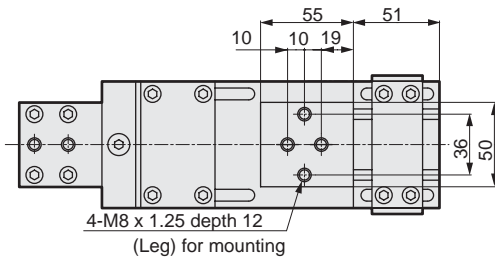
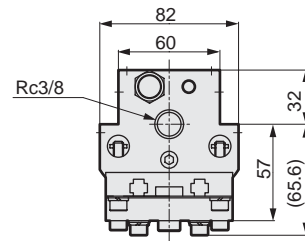
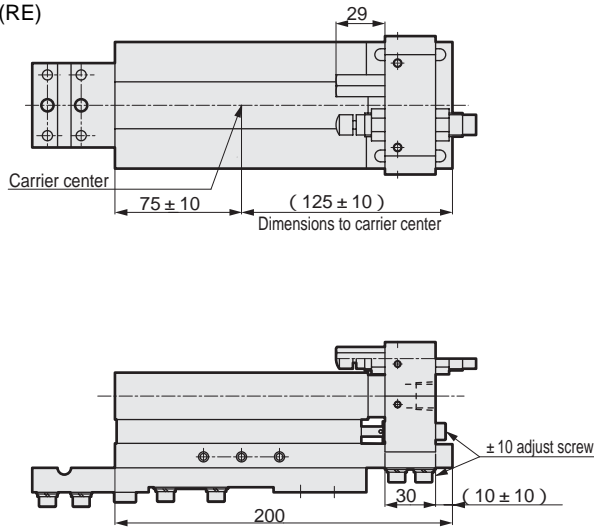

#### ● Rail end/high load type (RE-H)

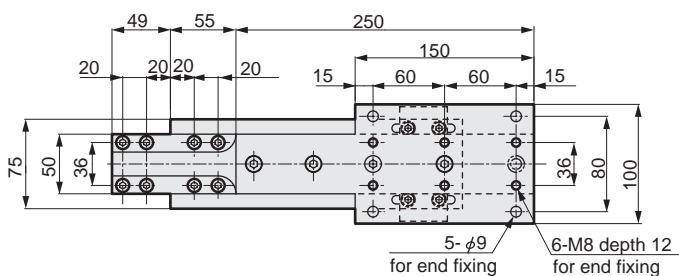
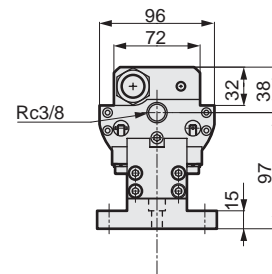
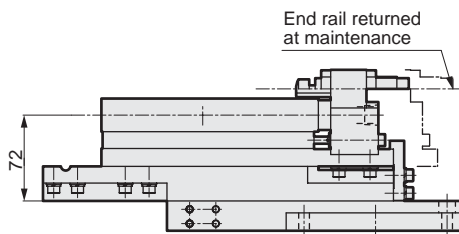
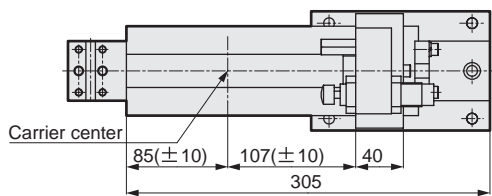

SCP*2
CMK2
CMA2
SCM
SCG
SCA2
SCS
CKV2
CA/OV2
SSD
CAT
MDC2
MVC
SMD2
MSD*
FC*
STK
ULK*
JSK/M2
JSG
JSC3
USSD
USC
JSB3
LMB
STG
STS/L
LCS
LCG
LCM
LCT
LCY
STR2
UCA2
HCM
HCA
<b>SRL2</b>
<b>SRG</b>
<b>SRM</b>
<b>SRT</b>
<b>MRL2</b>
<b>MRG2</b>
<b>SM-25</b>
CAC3
UCAC
RCC2
MFC
SHC
GLC
Ending

Shuttle mover  
 Rodless type

## Dimensions

### ● Air supply unit (PP)

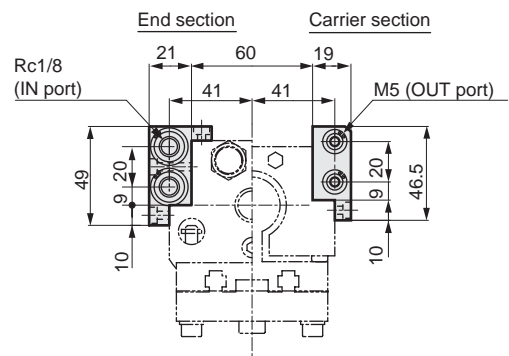
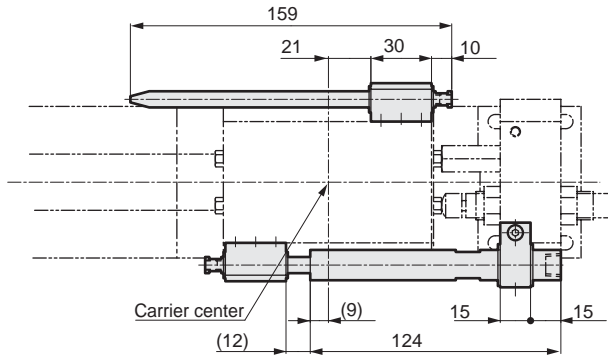

### ● Air supply unit/high load type (PP-H)

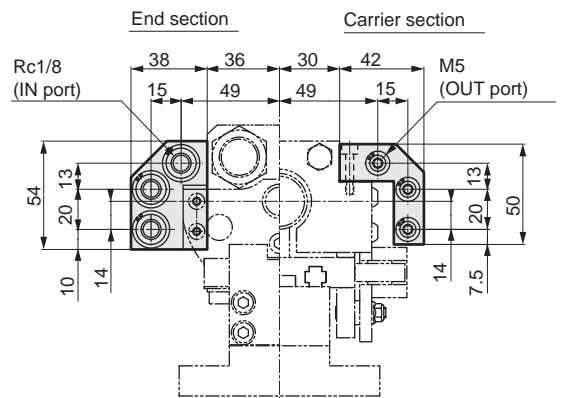
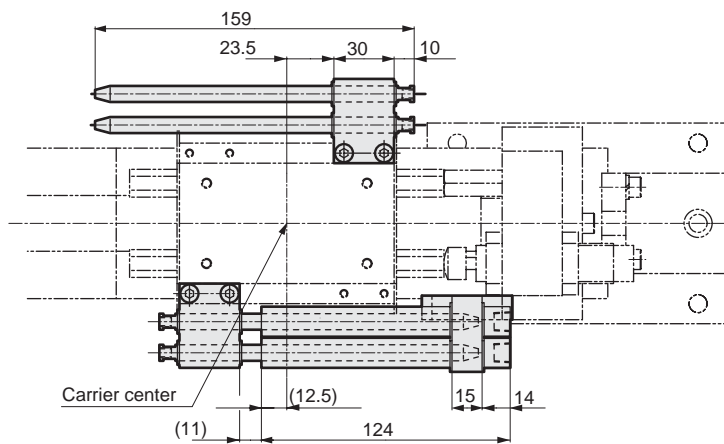

SCP*2
CMK2
CMA2
SCM
SCG
SCA2
SCS
CKV2
CA/OV2
SSD
CAT
MDC2
MVC
SMD2
MSD*
FC*
STK
ULK*
JSK/M2
JSG
JSC3
USSD
USC
JSB3
LMB
STG
STS/L
LCS
LCG
LCM
LCT
LCY
STR2
UCA2
HCM
HCA
SRL2
SRG
SRM
SRT
MRL2
MRG2
<b>SM-25</b>
CAC3
UCAC
RCC2
MFC
SHC
GLC
Ending

## Dimensions

● Air supply unit (PR)

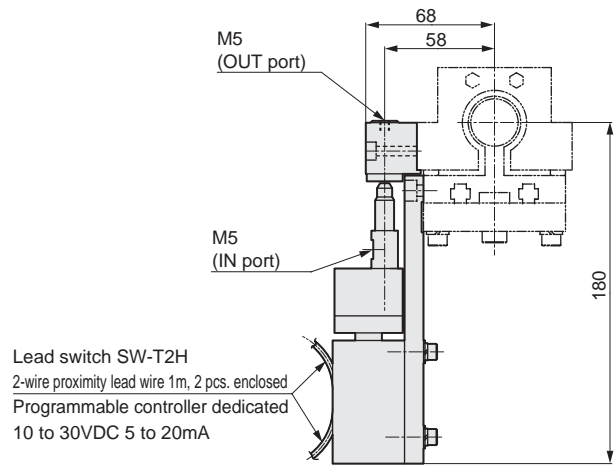
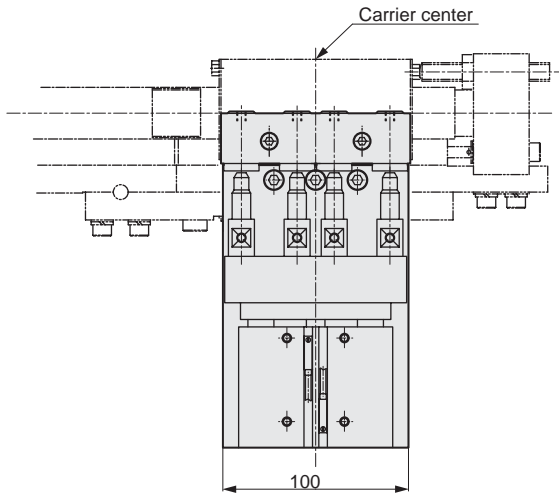

● Air supply unit/high load type (PR-H)

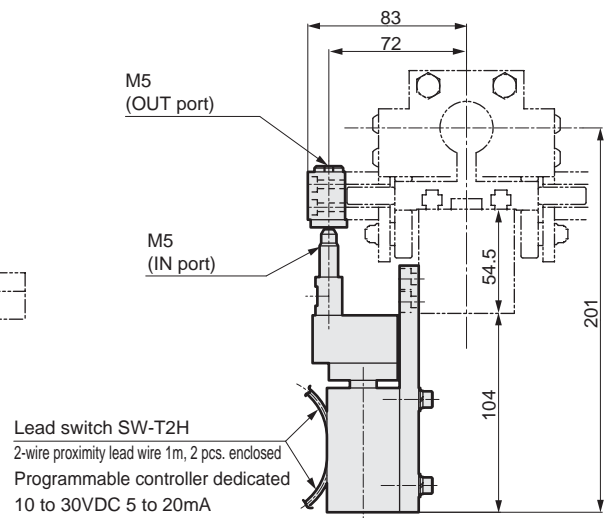
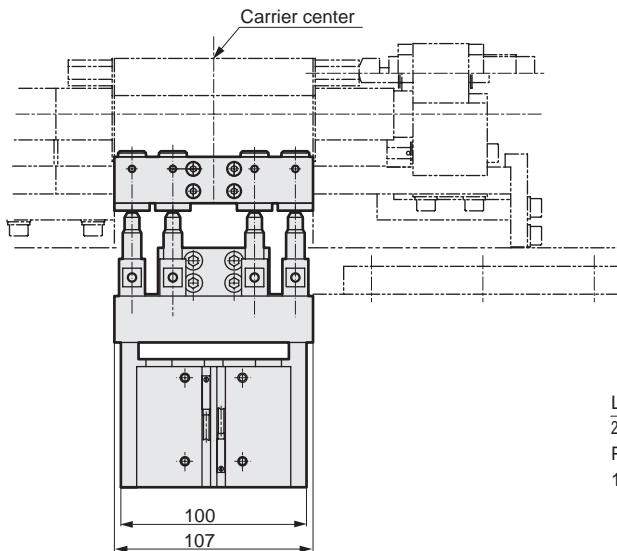

SCP*2
CMK2
CMA2
SCM
SCG
SCA2
SCS
CKV2
CA/OV2
SSD
CAT
MDC2
MVC
SMD2
MSD*
FC*
STK
ULK*
JSK/M2
JSG
JSC3
USSD
USC
JSB3
LMB
STG
STS/L
LCS
LCG
LCM
LCT
LCY
STR2
UCA2
HCM
HCA
<b>SRL2</b>
<b>SRG</b>
<b>SRM</b>
<b>SRT</b>
<b>MRL2</b>
<b>MRG2</b>
<b>SM-25</b>
CAC3
UCAC
RCC2
MFC
SHC
GLC
Ending

Shuttle mover  
Rodless type

## Dimensions

SCP*2
CMK2
CMA2
SCM
SCG
SCA2
SCS
CKV2
CA/OV2
SSD
CAT
MDC2
MVC
SMD2
MSD*
FC*
STK
ULK*
JSK/M2
JSG
JSC3
USSD
USC
JSB3
LMB
STG
STS/L
LCS
LCG
LCM
LCT
LCY
STR2
UCA2
HCM
HCA
SRL2
SRG
SRM
SRT
MRL2
MRG2
<b>SM-25</b>
CAC3
UCAC
RCC2
MFC
SHC
GLC
Ending

### ● Joint (RJ)

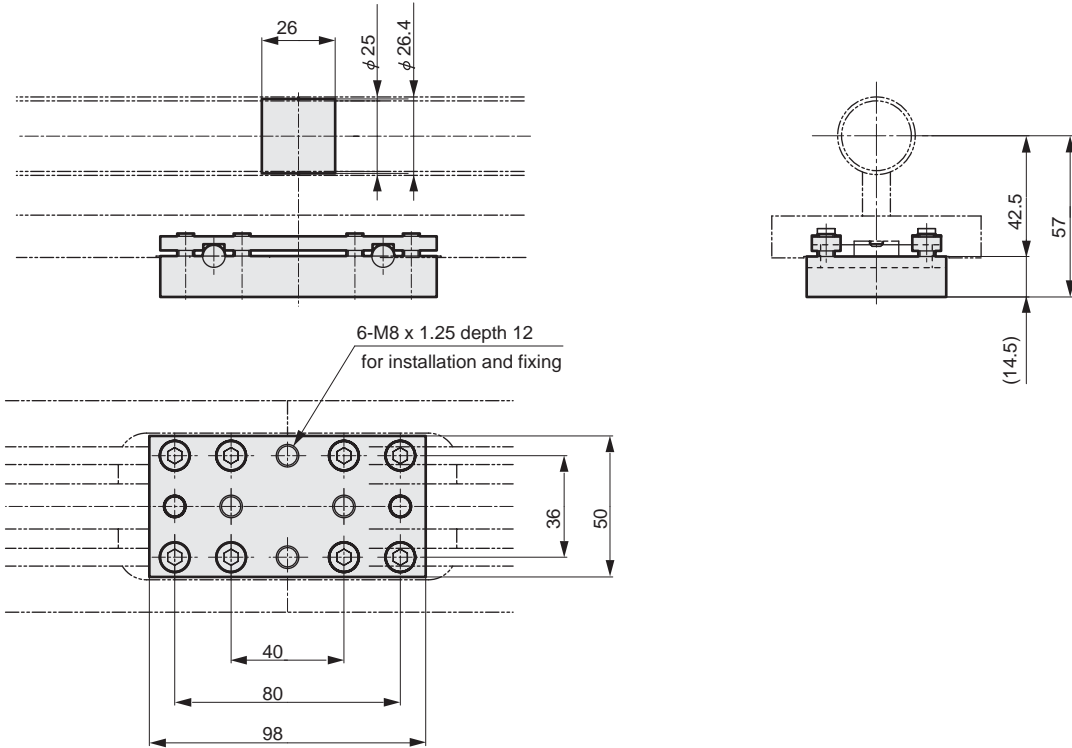

### ● Joint/high load type (RJ-H)

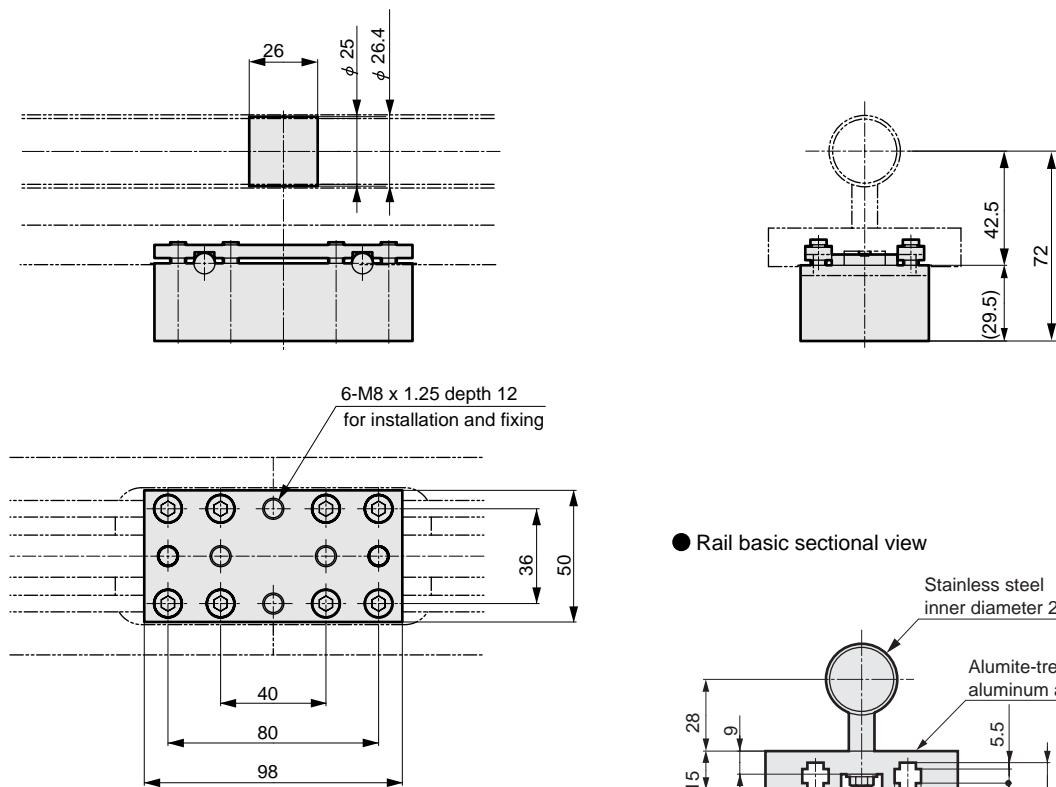

### ● Rail basic sectional view

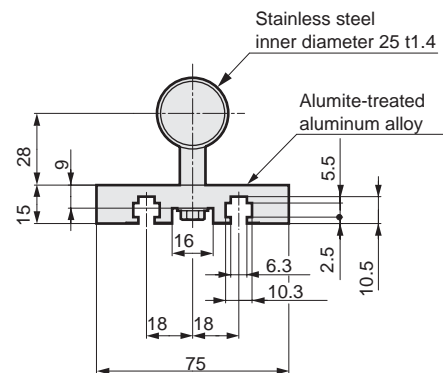

# SM-25 Series

**Dimensions** Only the joint is different for the ST (standard type) and ST-H (high load type). The unit body dimensions are the same.

● Straight unit (ST) · high load type (ST-H)

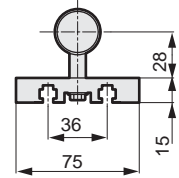
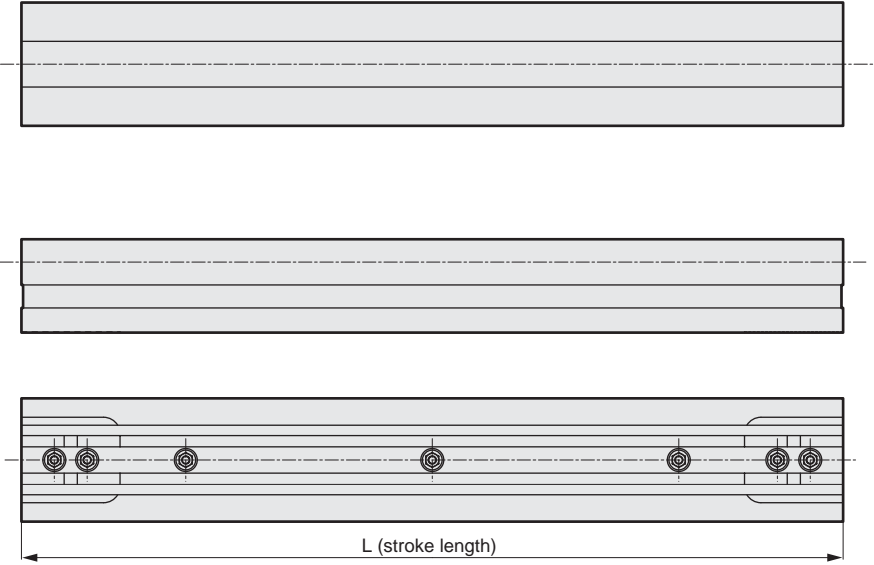

SCP*2
CMK2
CMA2
SCM
SCG
SCA2
SCS
CKV2
CA/OV2
SSD
CAT
MDC2
MVC
SMD2
MSD*
FC*
STK
ULK*
JSK/M2
JSG
JSC3
USSD
USC
JSB3
LMB
STG
STS/L
LCS
LCG
LCM
LCT
LCY
STR2
UCA2
HCM
HCA
<b>SRL2</b>
<b>SRG</b>
<b>SRM</b>
<b>SRT</b>
<b>MRL2</b>
<b>MRG2</b>
<b>SM-25</b>
CAC3
UCAC
RCC2
MFC
SHC
GLC
Ending

**Dimensions** Only the joint is different for the ST (standard type) and ST-H (high load type). The unit body dimensions are the same.

● Horizontal curve unit 90° (SC90) · high load type (SC-H90)

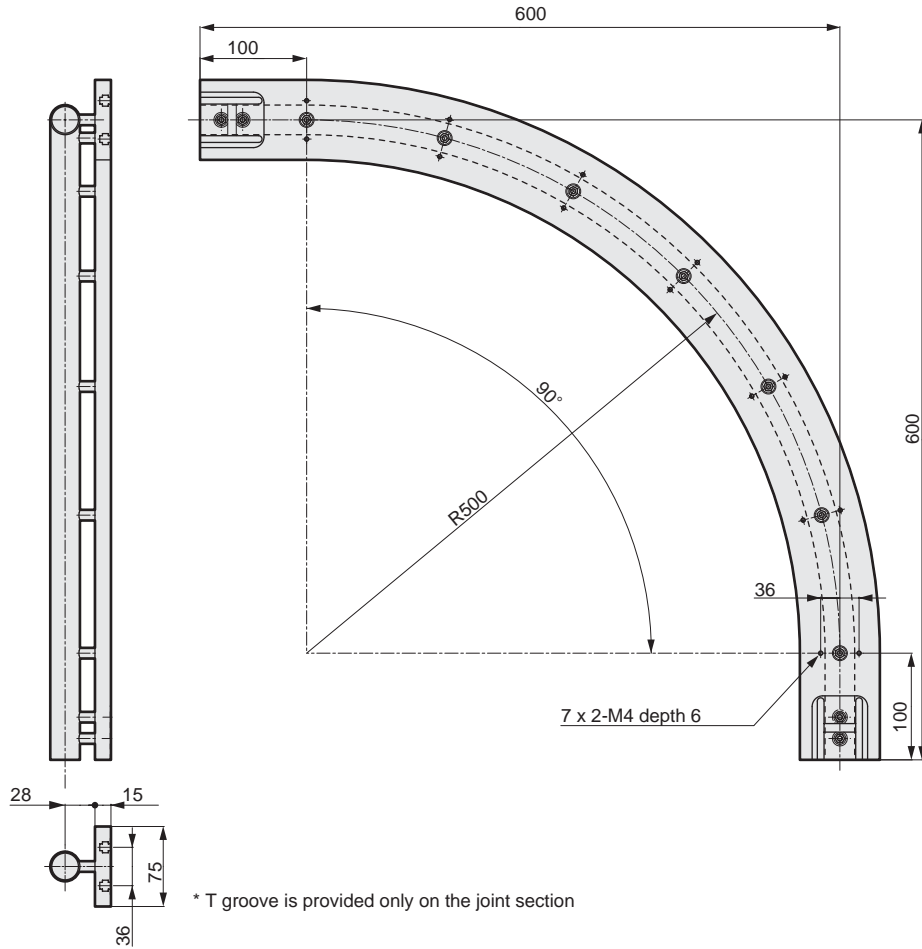

● Horizontal curve unit 45° (SC45) · high load type (SC-H45)

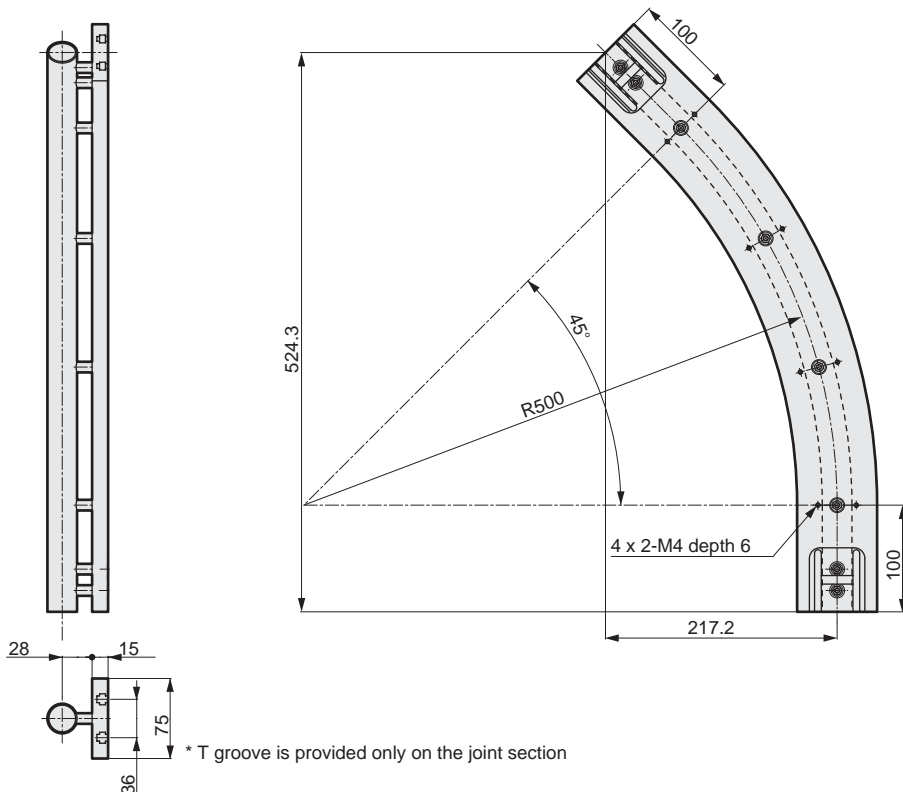

SCP*2
CMK2
CMA2
SCM
SCG
SCA2
SCS
CKV2
CA/OV2
SSD
CAT
MDC2
MVC
SMD2
MSD*
FC*
STK
ULK*
JSK/M2
JSG
JSC3
USSD
USC
JSB3
LMB
STG
STS/L
LCS
LCG
LCM
LCT
LCY
STR2
UCA2
HCM
HCA
SRL2
SRG
SRM
SRT
MRL2
MRG2
<b>SM-25</b>
CAC3
UCAC
RCC2
MFC
SHC
GLC
Ending

Shuttle mover  
Rodless type

**Dimensions** Only the joint is different for the ST (standard type) and ST-H (high load type). The unit body dimensions are the same.

● Vertical (inside) curve unit 90° (VC-90-IN) · high load type (VC-H90-IN)

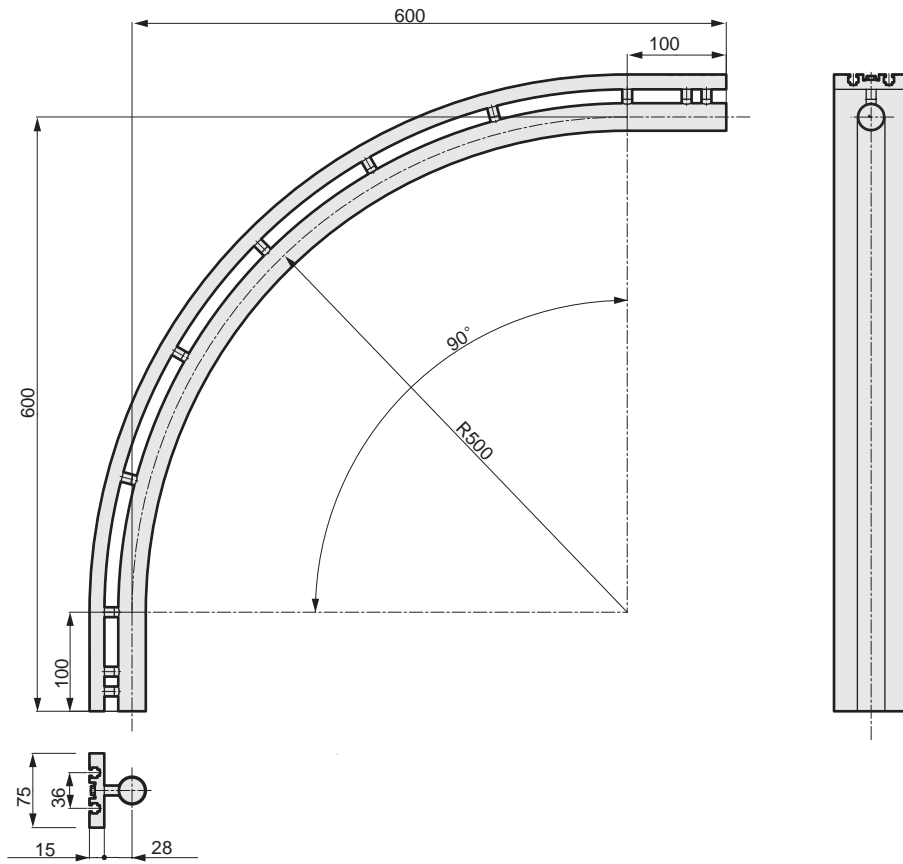

● Vertical (inside) curve unit 45° (VC-45-IN) · high load type (VC-H45-IN)

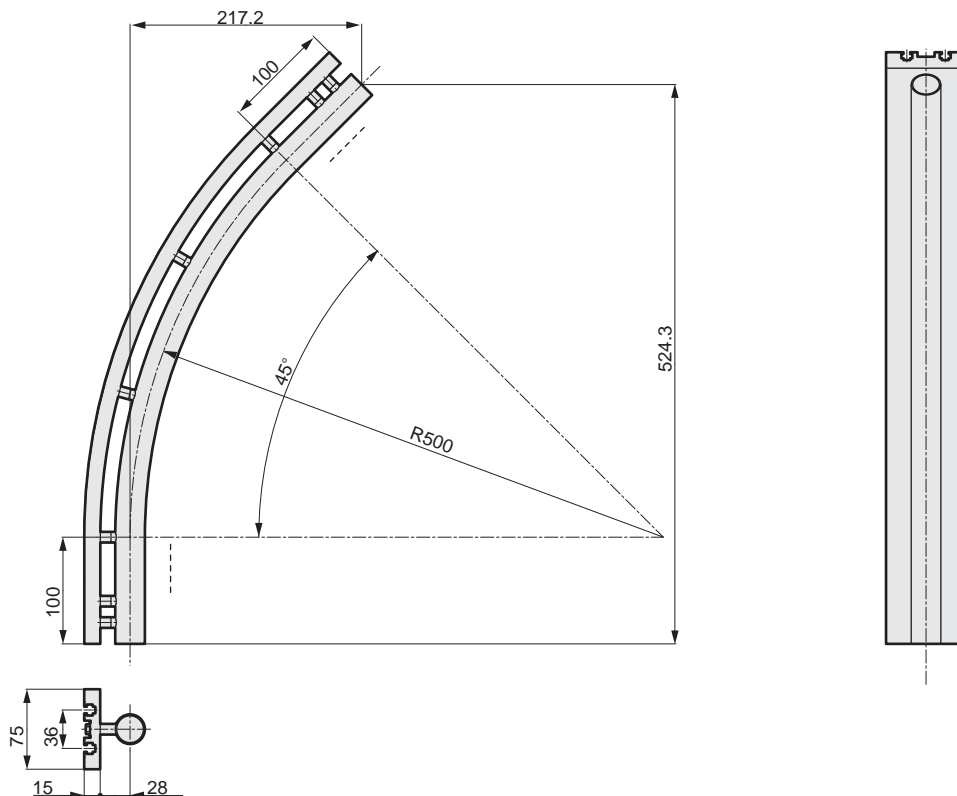

- SCP\*2
- CMK2
- CMA2
- SCM
- SCG
- SCA2
- SCS
- CKV2
- CA/OV2
- SSD
- CAT
- MDC2
- MVC
- SMD2
- MSD\*
- FC\*
- STK
- ULK\*
- JSK/M2
- JSG
- JSC3
- USSD
- USC
- JSB3
- LMB
- STG
- STS/L
- LCS
- LCG
- LCM
- LCT
- LCY
- STR2
- UCA2
- HCM
- HCA
- SRL2
- SRG
- SRM
- SRT
- MRL2
- MRG2
- SM-25**
- CAC3
- UCAC
- RCC2
- MFC
- SHC
- GLC
- Ending



**Dimensions** Only the joint is different for the ST (standard type) and ST-H (high load type). The unit body dimensions are the same.

● Vertical (out) curve unit 90° (VC-90-OUT) · high load type (VC-H90-OUT)

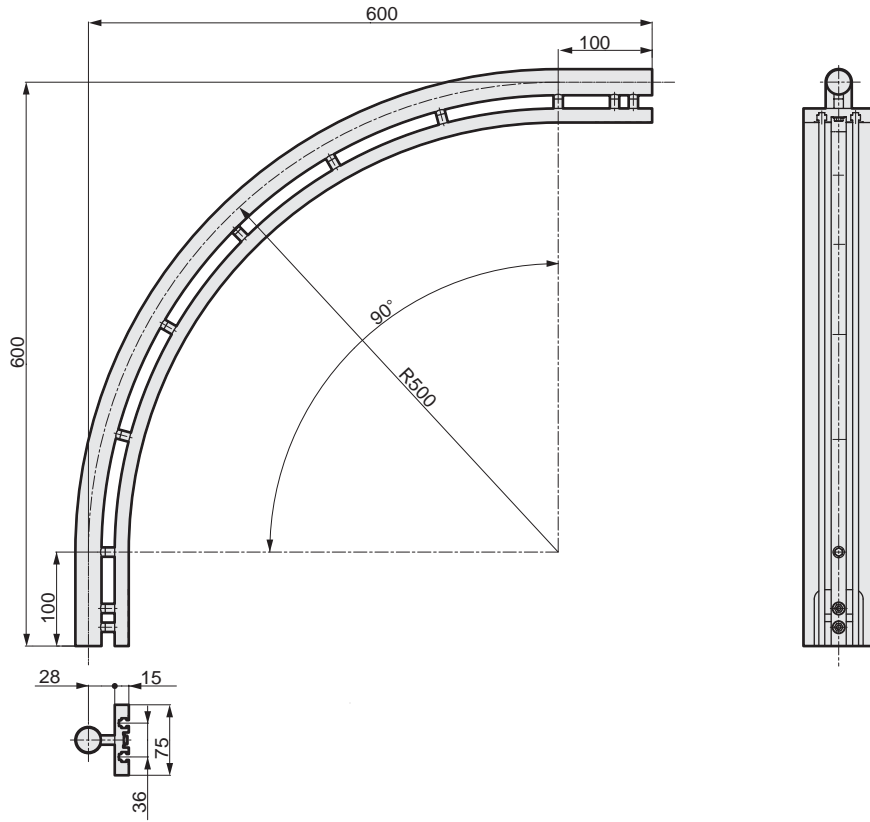

● Vertical (out) curve unit 45° (VC-45-OUT) · high load type (VC-H45-OUT)

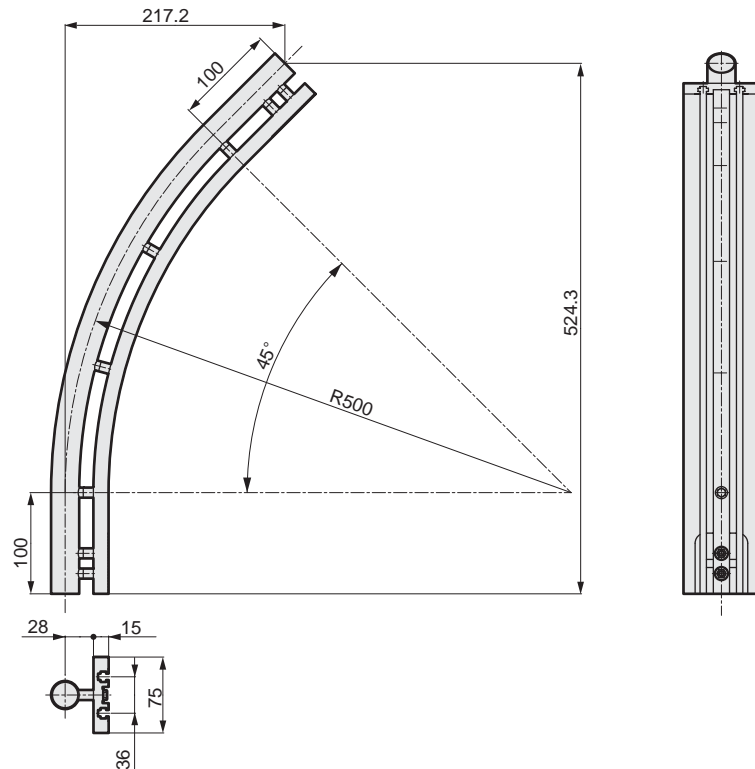

SCP*2
CMK2
CMA2
SCM
SCG
SCA2
SCS
CKV2
CA/OV2
SSD
CAT
MDC2
MVC
SMD2
MSD*
FC*
STK
ULK*
JSK/M2
JSG
JSC3
USSD
USC
JSB3
LMB
STG
STS/L
LCS
LCG
LCM
LCT
LCY
STR2
UCA2
HCM
HCA
SRL2
SRG
SRM
SRT
MRL2
MRG2
<b>SM-25</b>
CAC3
UCAC
RCC2
MFC
SHC
GLC
Ending

Shuttle mover  
Rodless type

## Technical data

### 1 Basic circuit diagram

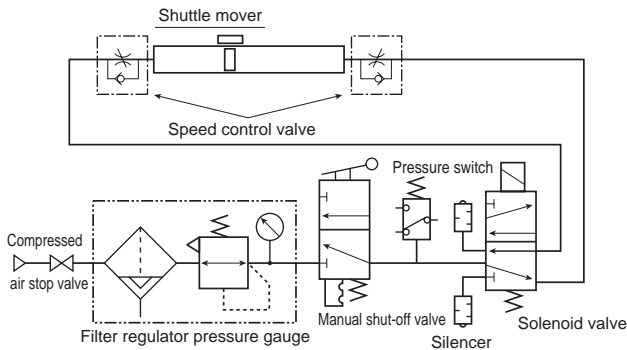

### 2 Selection guide

The maximum allowable load weight carries according to the overhang amount of the load's weighted center and the working average speed.

Select so that both step 1 and step 2 below are satisfied.

#### STEP 1 Load weight and overhang amount

\* The allowable load weight differs according to the overhang amount.

Use within the range shown in graph (1).

\* Refer to the selection examples for details on calculating the overhang amount L.

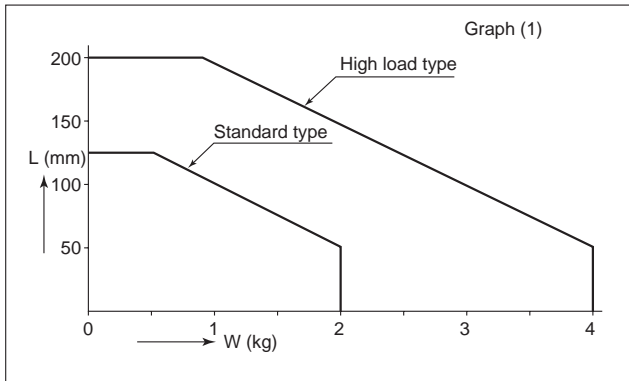

#### STEP 2 Load weight and average speed

\* The usable average speed differs according to the load weight.

Use within the range shown in graph (2).

\* When using with an average speed of 0.5m/s or more, a deceleration circuit such as a shock-less valve (SKH series) is required.

\* Refer to the corresponding page on the "General Pneumatic Components" for details on selecting and using the shock-less valve (SKH Series).

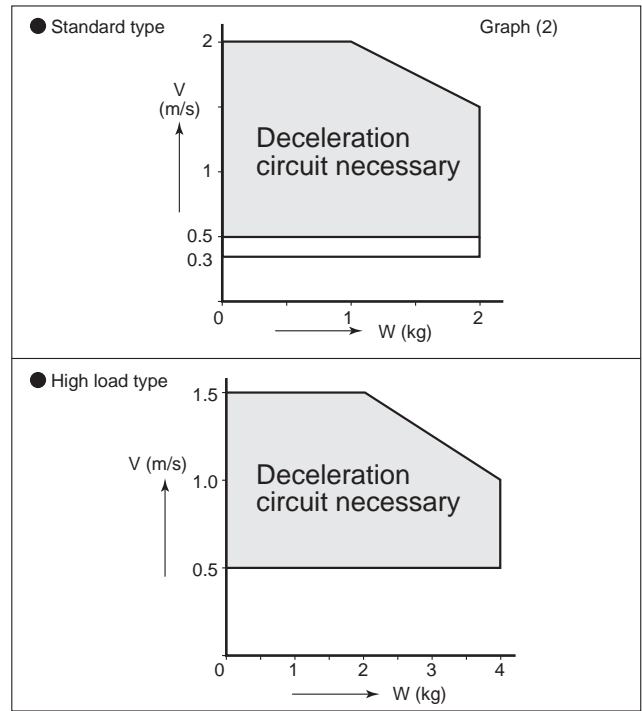

#### ● Example of selection

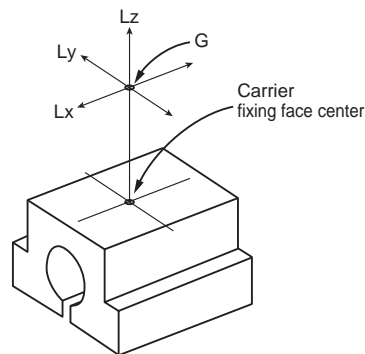
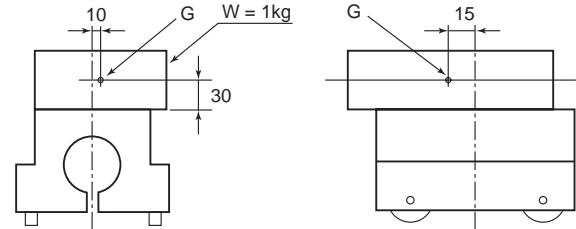

W : Load weight  
 G : Load center of gravity  
 Lx : Misalignment of X direction of G  
 Ly : Misalignment of Y direction of G  
 Lz : Misalignment of Z direction of G  
 L : Overhang length  
 $L = Lx + Ly + Lz$

W = 1kg  
 V = 1.5m/s  
 Lx = 15mm  
 Ly = 10mm  
 Lz = 30mm  
 $L = 15 + 10 + 30 = 55\text{mm}$

When using with a load weight of 1kg and speed of 1.5m/s, if W = 1kg according to graph (2), the speed is 2m/s and is within the range. However, a deceleration circuit is required.

In respect to the deviation of the load's weighted center, if W = 1kg according to graph (1), L = 55mm weighted center deviation which is within the allowable range as up to 100mm is allowable.

### Technical data

#### ● Example of deceleration circuit diagram

\* Example of using shock-less valve

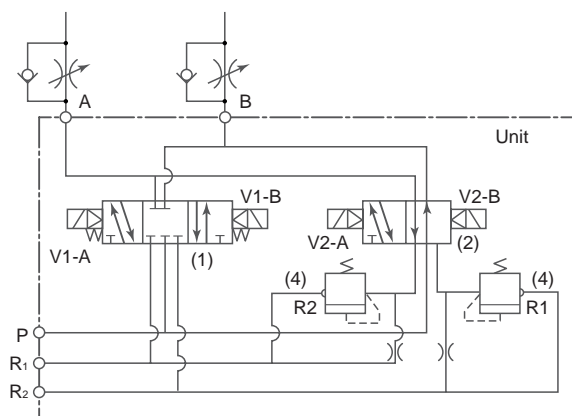

Part name	Type no.	Number	Remarks
1 Solenoid valve	4KB339	1	High speed
2 Solenoid valve	4KB329	1	Low speed
3 Manifold block		1	
4 Spacer relief valve	SKH-3SR	1	

#### ● Other cautions

- (1) A shuttle valve is required when operating a single-action chuck, etc., with the air supply unit (PP).
- (2) For the installation frame, prepare a mechanism which can be adjusted in the vertical direction (use a leveling bolt, etc.), and fix with an anchor bolt, etc., after the final adjustment is completed.
- (3) The legs should be installed at a pitch of approx. 2m.
- (4) When transferring workpieces between the shuttle mover and user's equipment (conveyor, etc.), provide a transfer position adjustment mechanism on the user's equipment.
- (5) All other detailed designs must be discussed. Contact a CKD sales representative for more information.

### 3 Stroke of each unit

Unit name	Type no.	Stroke length (mm)
Rail end	RE	75 ± 10
Straight unit	(example) ST-100	100
	ST-200	200
	ST-1000	1000
	ST-1015	1015
	ST-2000	2000
Curve unit 90°	SC90	985
	VC90-IN	
	VC90-OUT	
Curve unit 45°	SC45	590
	VC45-IN	
	VC45-OUT	

\* The stroke is the same for the standard type and high load type.

### 4 Curve unit shortest combination dimensions

1) 90 and 90 degree

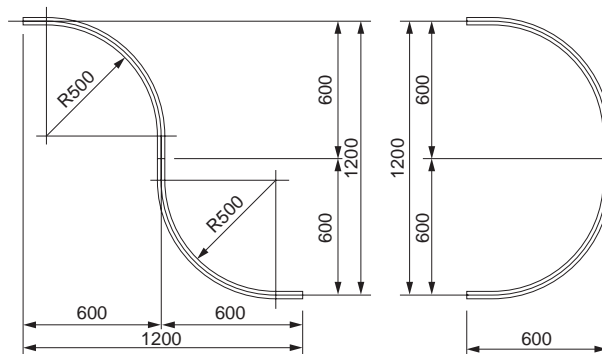

2) 45 and 45 degree

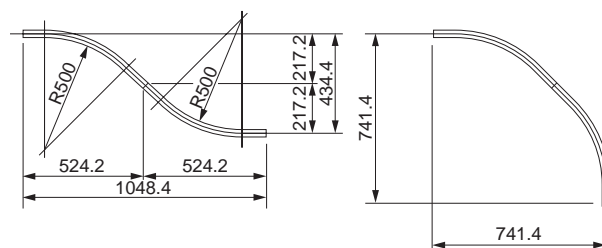

3) 90 and 45 degree

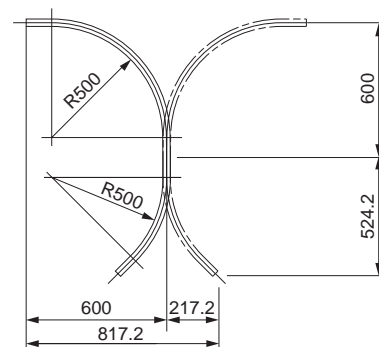

SCP*2
CMK2
CMA2
SCM
SCG
SCA2
SCS
CKV2
CA/OV2
SSD
CAT
MDC2
MVC
SMD2
MSD*
FC*
STK
ULK*
JSK/M2
JSG
JSC3
USSD
USC
JSB3
LMB
STG
STS/L
LCS
LCG
LCM
LCT
LCY
STR2
UCA2
HCM
HCA
SRL2
SRG
SRM
SRT
MRL2
MRG2
<b>SM-25</b>
CAC3
UCAC
RCC2
MFC
SHC
GLC
Ending

Shuttle mover  
Rodless type

# Q uestion & A nswer

## Design

**Q** Can the carrier be braked?

**A** Braking is not possible.

**Q** What is the SM-25's air consumption rate?

**A** The rate is the same as a typical  $\phi 25$  bore size cylinder.

**Q** When estimating the transfer time, what rate (m/s) should be used for the speed?  
(When estimating in consideration of the various conditions including rail combination, difference in load weight, deceleration time or working pressure, etc.)

**A** Estimate at 1m/s.  
(Example: At a 20m stroke,  $20\text{m} \div 1\text{m/s} = 20\text{s}$ . The workpiece's loading time is not included in this time.)

**Q** Does the maximum allowable load rate refer to the workpiece's weight?

**A** This is the weight of the total load put on the carrier.  
The hand chuck and Z axis cylinder are included in this value.

SCP*2
CMK2
CMA2
SCM
SCG
SCA2
SCS
CKV2
CA/OV2
SSD
CAT
MDC2
MVC
SMD2
MSD*
FC*
STK
ULK*
JSK/M2
JSG
JSC3
USSD
USC
JSB3
LMB
STG
STS/L
LCS
LCG
LCM
LCT
LCY
STR2
UCA2
HCM
HCA
SRL2
SRG
SRM
SRT
MRL2
MRG2
<b>SM-25</b>
CAC3
UCAC
RCC2
MFC
SHC
GLC
Ending

## Safety

**Q** Is a safety cover required?

**A** Always install a cover since this joint type air cylinder may be used for overhead travel at a high speed.

**Q** What happens if the carrier is not decelerated at the stroke end?  
(At 0.5m/s or more)

**A** The shock absorber could be damaged. Always provide a deceleration circuit such as a shock-less valve (SKH Series).

## Maintenance

**Q** Can the carrier's roller be replaced?

**A** Dedicated tools are required, so contact CKD for overhaul (paid-for-service).

**Q** Do the carrier rollers need to be oiled?

**A** Shielded metal bearings with urethane rubber are used, so the carrier rollers can be used in a non-oiled state.

**Q** How can the stroke be adjusted?

**A** The stroke can be adjusted 10mm forward or 10mm backward at the rail end. Refer to the instruction manual for details on adjusting the stroke.

## Electric Control

**Q** Is there a carrier detection lead switch?

**A** There is no lead switch.  
Use a proximity sensor, photo electric sensor or a photo sensor.

**Q** How should the electrical signals for the actuator mounted on the carrier be output?

**A** The signals cannot be output as there is no electricity supply to the operation confirmation lead switch, etc.

SCP*2
CMK2
CMA2
SCM
SCG
SCA2
SCS
CKV2
CA/OV2
SSD
CAT
MDC2
MVC
SMD2
MSD*
FC*
STK
ULK*
JSK/M2
JSG
JSC3
USSD
USC
JSB3
LMB
STG
STS/L
LCS
LCG
LCM
LCT
LCY
STR2
UCA2
HCM
HCA
SRL2
SRG
SRM
SRT
MRL2
MRG2
<b>SM-25</b>
CAC3
UCAC
RCC2
MFC
SHC
GLC
Ending

Shuttle mover  
Rodless type