

# CC CABLE CYLINDER

## RODLESS CYLINDER



### CONTENTS

Features .....	cc_2
Applications .....	cc_4
Performance .....	cc_5
Double Acting Cable Cylinder .....	cc_6
CC05, CC07, CC10 .....	cc_7
CC15 .....	cc_8
CC20, CC25 .....	cc_9
CC30, CC40, CC52 .....	cc_10
CC50 .....	cc_11
Single Acting Cable Cylinder .....	cc_12
SA07, SA10, SA15 .....	cc_13
SA20, SA25 .....	cc_14
SA30, SA40, SA52, SA50 .....	cc_15
Double Purchase Cable Cylinder .....	cc_16
DP15, DP20, DP25 .....	cc_17
DP30, DP40, DP52 .....	cc_18
Track Cable Cylinder .....	cc_19
TC05, TC07, TC10 .....	cc_20
TC15 .....	cc_21
Automatic Tensioner .....	cc_22
CC07,10,15,20,25 .....	cc_23
CC30,40,52,50 .....	cc_24
CC/Brake Combination .....	cc_25
CC15, CC20, CC25 .....	cc_26
CC30, CC40, CC52 .....	cc_27
Switches .....	cc_28
CC Selection Guidelines .....	cc_30
CC/Brake Selection Guidelines .....	cc_32
TC Selection Guidelines .....	cc_35
CC Application Guidelines .....	cc_36
Application Guidelines .....	cc_38
Service Parts .....	cc_39
Ordering .....	cc_40

# CABLE CYLINDER

## ENDURANCE TECHNOLOGY<sup>SM</sup>

Endurance Technology features are designed for maximum durability to provide extended service life.

Tolomatic invented the first ever rodless cylinder in 1956 - the cable cylinder. First designed into the bagger/sealer used in the flour industry the cable cylinder continues to power applications in the 21st century. Built-to-order in stroke lengths up to 282 inches.

### HIGH STRENGTH TUBE

- High-strength, lightweight, black anodized aluminum or steel
- Creates chamber for pneumatic or hydraulic pressure and protects piston



### STEEL CLEVIS

- High strength material resists deformation
- Cable adjustment points
- Threaded holes for load attachment



### DOUBLE ACTING CABLE CYLINDER

The Tolomatic double-acting cable cylinder is a versatile space saver, available in all 9 bore sizes. Enjoy cost savings over conventional rod cylinders in strokes over four feet without experiencing rod buckle.

These cylinders can be isolated from any work area with extended cable lengths and achieve strokes of up to 60 feet in length.

### PORTING CHOICES

- Choose from 2 or 3 port heads

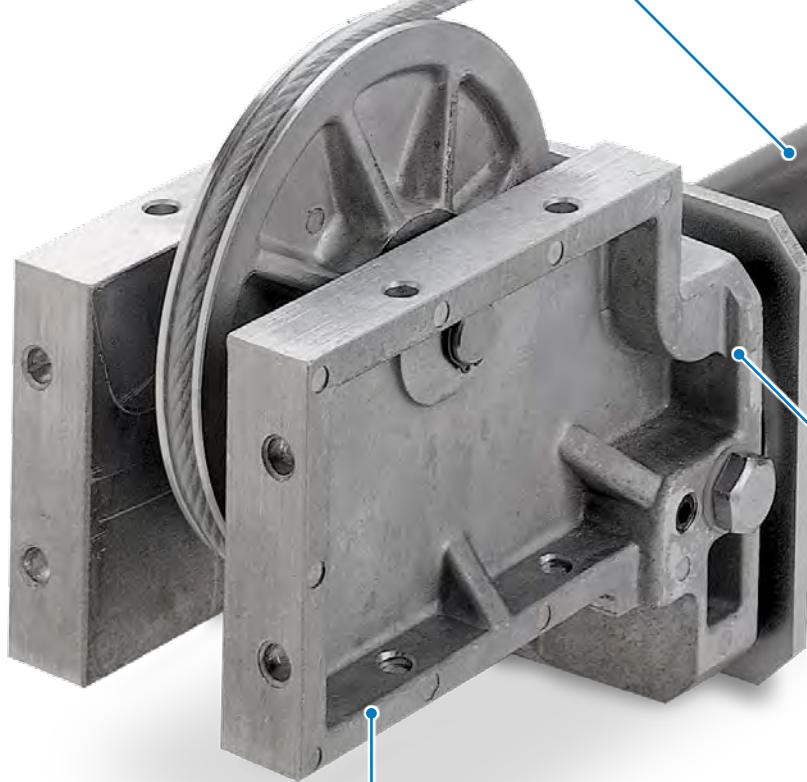

### ALUMINUM PISTON

- High-strength, lightweight aluminum
- Pulls the cables when actuated by pneumatic or hydraulic pressure



### DIE CAST HEAD ASSEMBLY

- High-strength, lightweight anodized aluminum
- Protects piston and creates chamber for pneumatic or hydraulic pressure

### LOCATE REMOTELY

- Cylinder can be located away from work area. Useful in harsh environments and if space/weight are limited

### UNIQUE GLAND SEALS

- Tight seal for cables to pass through
- Easy installation
- Snap In/Out cable seals or encapsulated gland seals depending on bore size

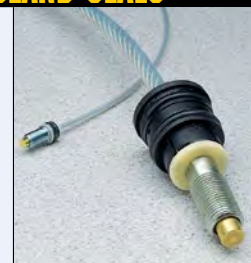



# TOLOMATIC... THE RODLESS CYLINDER LEADER



## MIL SPEC CABLES

- Field proven to provide millions of cycles of uninterrupted service
- Nylon jacketed aircraft cables manufactured under Mil Spec. MIL-W-83420D

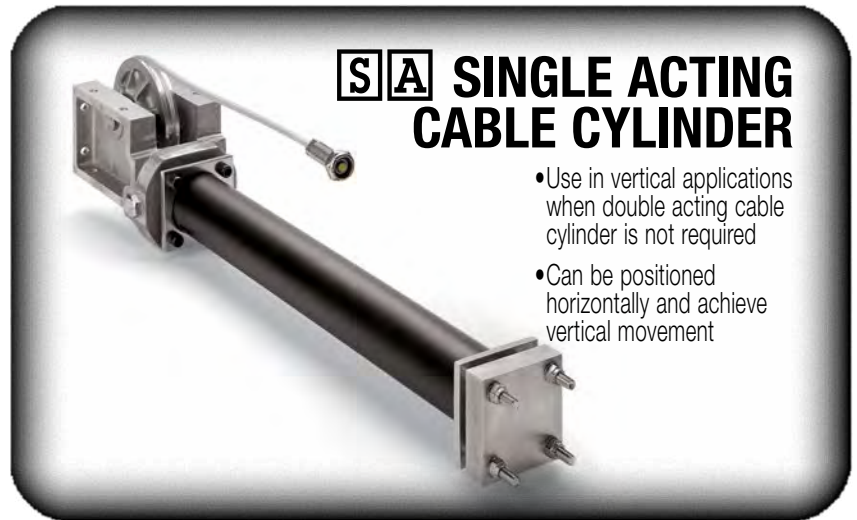

## SA SINGLE ACTING CABLE CYLINDER

- Use in vertical applications when double acting cable cylinder is not required
- Can be positioned horizontally and achieve vertical movement

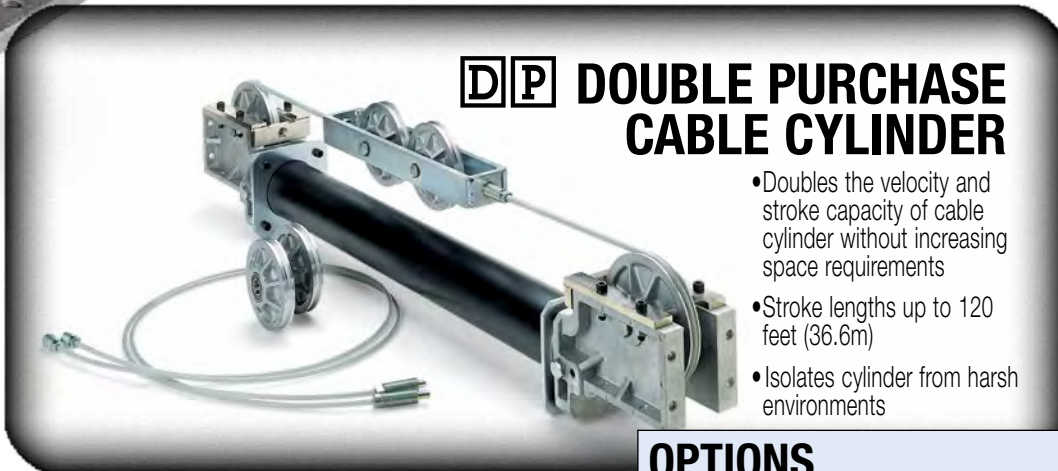

## DP DOUBLE PURCHASE CABLE CYLINDER

- Doubles the velocity and stroke capacity of cable cylinder without increasing space requirements
- Stroke lengths up to 120 feet (36.6m)
- Isolates cylinder from harsh environments

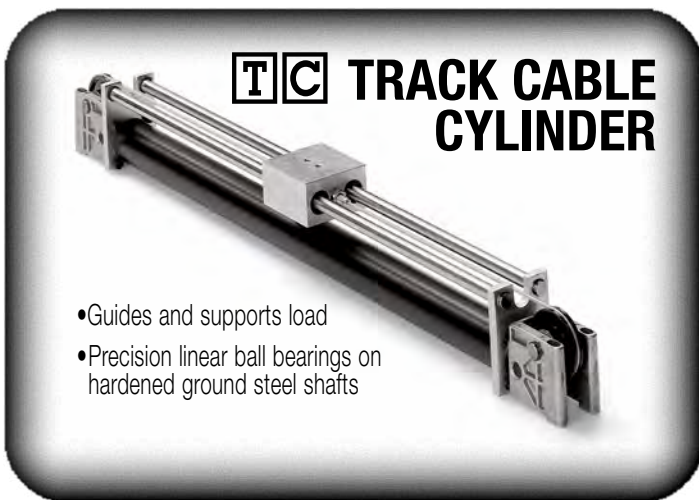

## TC TRACK CABLE CYLINDER

- Guides and supports load
- Precision linear ball bearings on hardened ground steel shafts

## OPTIONS



### AUTO TENSIONER

- Maintains proper cable tension
- Maximizes service life of both cable and seals



### CALIPER DISC BRAKE **HM HN**

- Best mounting choice in most applications

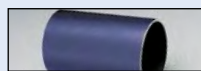

### STEEL TUBE

- For extra strength & use in harsh environments



### 3 PORTED HEAD

- For convenient air connection



### SWITCHES

- Available in Reed and Triac
- 15ft. cable with flying leads; available with quick-disconnect couplers



### SEALS OF VITON<sup>®</sup> MATERIAL **V**

- Long lasting seal option
- High temperature applications



### EXTRA CABLE **XA XB**

- To remotely locate cable cylinder



# CC Cable Cylinder

## APPLICATIONS

Tolomatic invented the first ever rodless cylinder in 1956 - the cable cylinder. First designed into the bagger/sealer used in the flour industry the cable cylinder continues to power applications in the 21st century. The cable cylinder has been a key component in the following industries:

- Packaging
- Automotive
- Food & Beverage
- Material Handling & Conveying
- Plastic Injection Molding
- Metal Processing
- Paper and Textiles
- Medical
- Electronics
- Printing
- Many Others

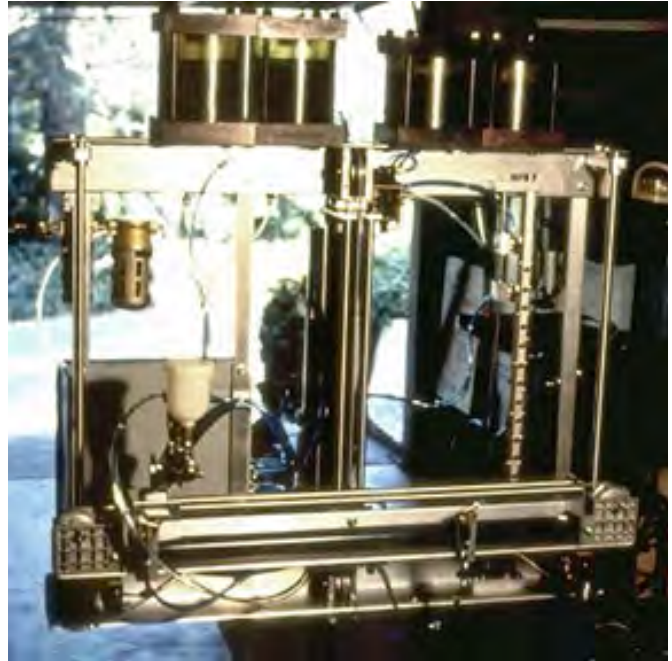
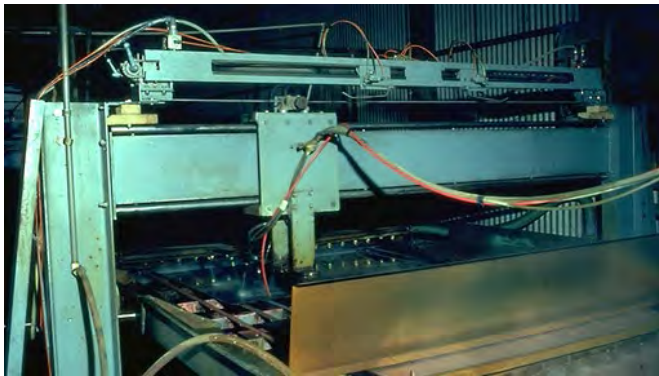
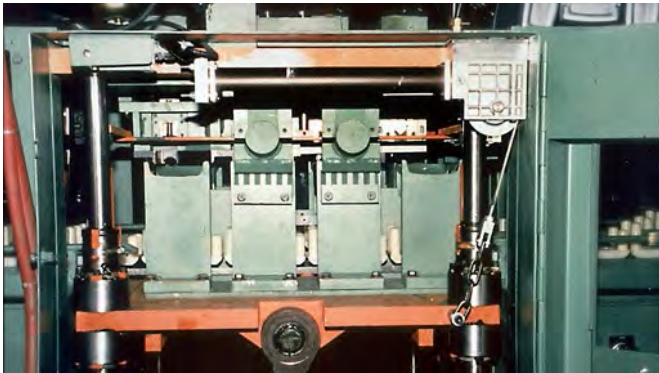



# CC Cable Cylinder

## PERFORMANCE

### CABLE CYLINDER THEORETICAL FORCE VS PRESSURE

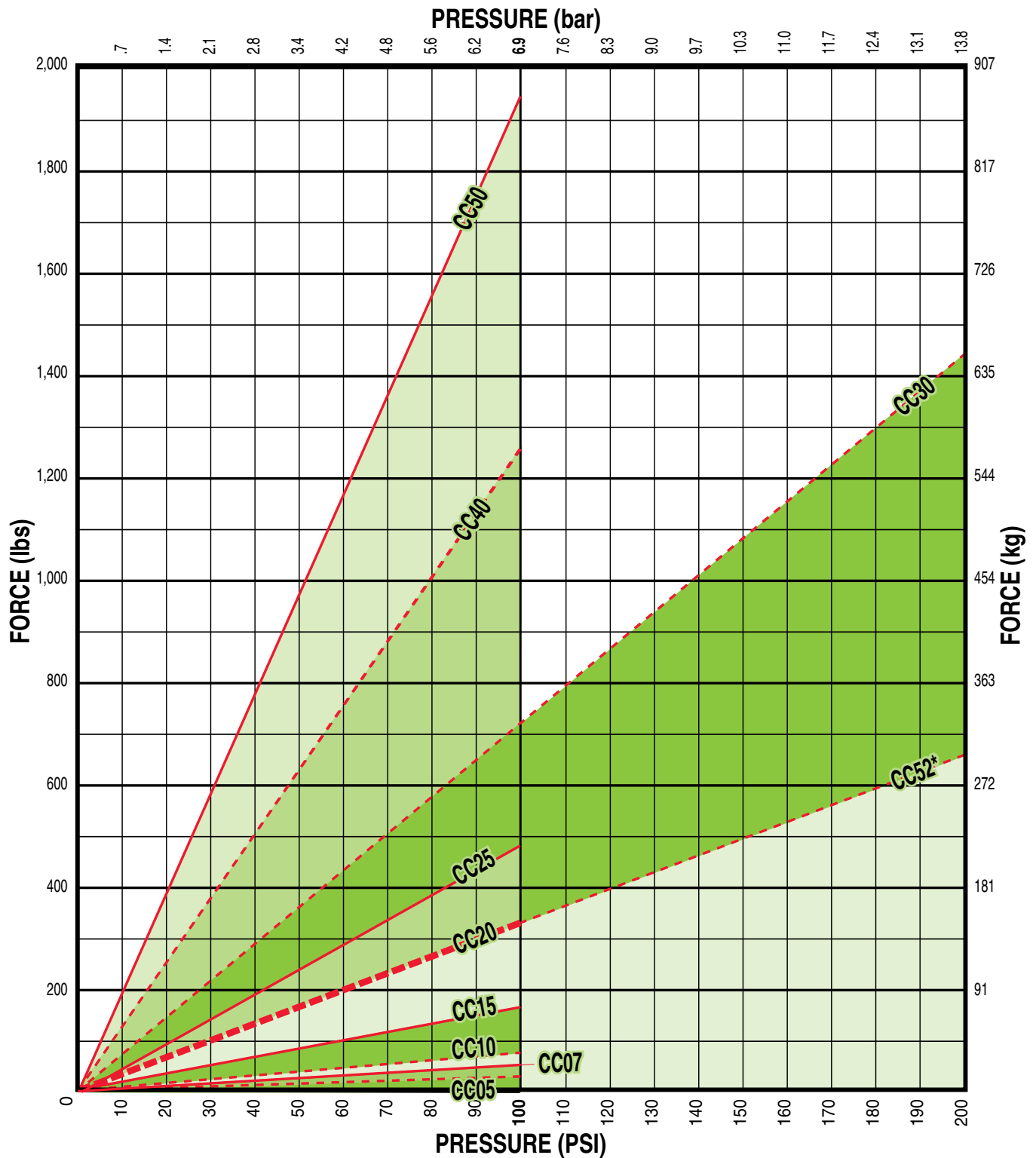

\*CC52 up to 500 psi

# CC Double Acting Cable Cylinder - All Sizes

## FEATURES AND OPTIONS



### ORDER CODES

**CC05, CC07, CC10  
CC15, CC20, CC25, CC30  
CC40, CC52, CC50  
inch (U.S. Standard)**

The Tolomatic double-acting cable cylinder is a versatile space saver, available in all 9 bore sizes. Enjoy cost savings over conventional rod cylinders in strokes over four feet with out experiencing rod buckle.

These cylinders can be isolated from any work area with extended cable lengths. Contact Tolomatic to achieve strokes of up to 60 feet in length.

CC OPTIONS	Order Code	Page	CC05	CC07	CC10	CC15	CC20	CC25	CC30	CC40	CC52	CC50
Auto Tensioner w/ one 1" Stroke Unit	HI, HJ	cc_22	-	OP	OP	OP	OP	OP	OP	OP	OP	-
Auto Tensioner w/ two 1" Stroke Units	HI, HJ	cc_22	-	OP	OP	OP	OP	OP	OP	OP	OP	-
Auto Tensioner w/ one 2" Stroke Unit	HK,HL	cc_22	-	-	-	-	OP	OP	OP	OP	OP	OP
Auto Tensioner w/ two 2" Stroke Units	HK,HL	cc_22	-	-	-	-	OP	OP	OP	OP	OP	OP
Caliper Disc Brake	HM, HN	cc_25	-	-	-	OP	OP	OP	OP	OP	OP	OP
Switches (DC Reed & Triac)	(several)	cc_28	OP	OP	OP	OP	OP	OP	OP	OP	OP	OP
Aluminum Tube			ST	ST	ST	ST	ST	ST	ST	ST	ST	ST
Steel Tube (Switches NOT available)	S		-	-	OP	OP	OP	OP	OP	OP	OP	OP
Seals of Viton® Material	V		-	OP	OP	OP	OP	OP	OP	OP	OP	OP
3 Ported Heads	HG		OP	OP	OP	OP	OP	OP	OP	OP	OP	OP
<b>MORE INFORMATION</b>	<b>Page</b>											
Application Guidelines	cc_36		ST	ST	ST	ST	ST	ST	ST	ST	ST	ST
Cushion Needle Adjustment	cc_38		-	ST	ST	ST	ST	ST	ST	ST	ST	ST
Ordering	cc_40		ST	ST	ST	ST	ST	ST	ST	ST	ST	ST
Selection	cc_30		ST	ST	ST	ST	ST	ST	ST	ST	ST	ST
Caliper Disc Brake Option Selection	cc_32		-	-	-	OP	OP	OP	OP	OP	OP	OP
<b>STANDARD FEATURE</b>	<b>Page</b>											
Fixed Orifice Cushions	cc_38		-	ST	ST	-	-	-	-	-	-	-
Adjustable Cushions	cc_38		-	-	-	ST	ST	ST	ST	ST	ST	ST
Single Ported Head			ST	ST	ST	ST	ST	ST	ST	ST	ST	ST

- = Not Available      OP = Optional      ST = Standard

# Double Acting Cable Cylinder - CC05, CC07, CC10

OVERALL UNIT SPECIFICATIONS				
		CC05	CC07	CC10
BORE SIZE	in	0.50	0.75	1.00
MAX STROKE	in	54	138	282
	mm	1372	3505	7163
BASE WEIGHT	Alum.	lb	1.38	1.38
		kg	0.63	0.63
	Steel	lb	NA	NA
		kg	NA	NA
WEIGHT PER UNIT OF STROKE	Alum.	lb per in	0.011	0.034
		g per mm	0.197	0.606
	Steel	lb per in	NA	NA
		g per mm	NA	NA
MAX PRESSURE	PSI	100	100	100
	bar	6.9	6.9	6.9
MAX TEMP	°F	140	140	140
	°C	60	60	60
MAX FORCE OUTPUT	lb	19.4	43.5	77.9
	N	86.3	193.5	346.5

TUBING SPECIFICATIONS				
		CC05	CC07	CC10
DEAD LENGTH*	in	1.11	1.18	1.31
	mm	28.2	30	33.3
WALL THICKNESS	in	0.0937	0.125	0.125
	mm	2.38	3.175	3.175
MATERIAL		Alum.	Alum.	Alum or Steel
TUBE SUPPORT SPAN	Alum.	in	60	60
		mm	1524	1524
	Steel	in	NA	NA
	mm	NA	NA	1981

\*Add to stroke length to determine overall length

CABLE SPECIFICATIONS				
		CC05	CC07	CC10
WIRE DIA	in	0.0468	0.0468	0.0468
	mm	1.189	1.189	1.189
NYLON O.D.	in	0.0937	0.0937	0.0937
	mm	2.38	2.38	2.38
STRAND CONFIGURATION		7 x 7	7 x 7	7 x 7
TENSILE STRENGTH	lb	270	270	270
	kg	122.47	122.47	122.47
PROOF-LOAD TORQUE	in-lb	15	15	15
	N-m	1.69	1.69	1.69
PRETENSIONING TORQUE	in-lb	2.5	2.5	2.5
	N-m	0.28	0.28	0.28

## THEORETICAL FORCE vs PRESSURE

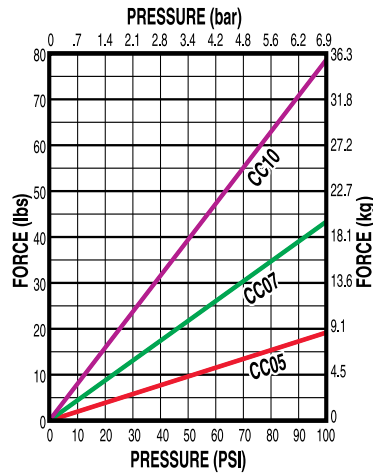

## CUSHION DATA

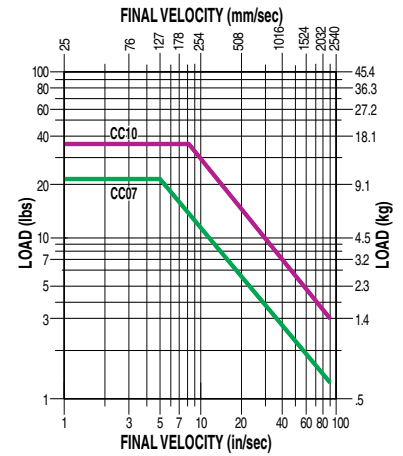

█ CC10  
█ CC07  
█ CC05

NOTE: The CC05 cylinder does not have cushions.

## DIMENSIONS

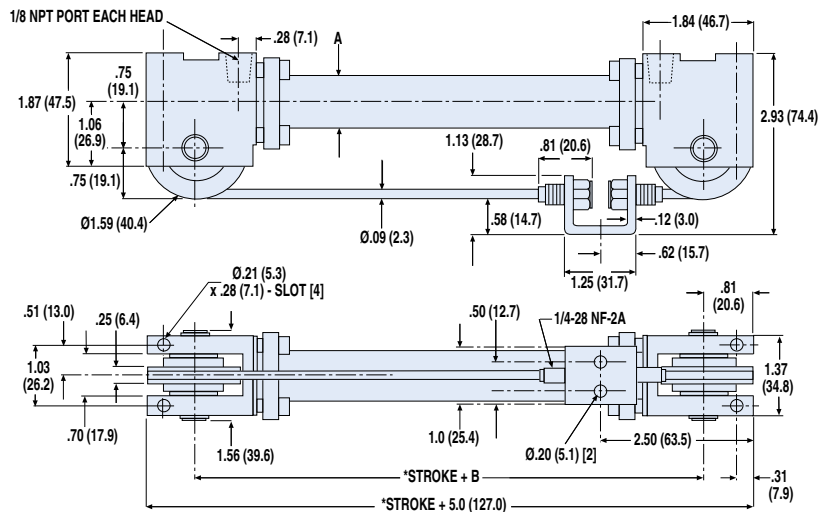

\*If M option (magnet) is ordered add 1.62" (41.2mm) to the overall length

	CC05	CC07	CC10
A	0.63 (16.0)	0.100 (25.4)	0.125 (31.8)
B	3.38 (85.8)	3.43 (87.1)	3.43 (87.1)

Dimensions in inches, in parentheses ( ) dimensions in millimeters



# Double Acting Cable Cylinder - CC15

## OVERALL UNIT SPECIFICATIONS

		CC15	
BORE SIZE	in	1.50	
	mm	38.1	
MAX STROKE	in	280	
	mm	7112	
BASE WEIGHT	Alum.	lb	5.12
		kg	2.32
	Steel	lb	5.27
		kg	2.39
WEIGHT PER UNIT OF STROKE	Alum.	lb per in	0.063
		g per mm	1.1259
	Steel	lb per in	0.181
		g per mm	3.2322
MAX PRESSURE	PSI	100	
	bar	6.9	
MAX TEMP	°F	140	
	°C	60	
MAX FORCE OUTPUT	lb	174	
	N	774.0	

## THEORETICAL FORCE vs PRESSURE

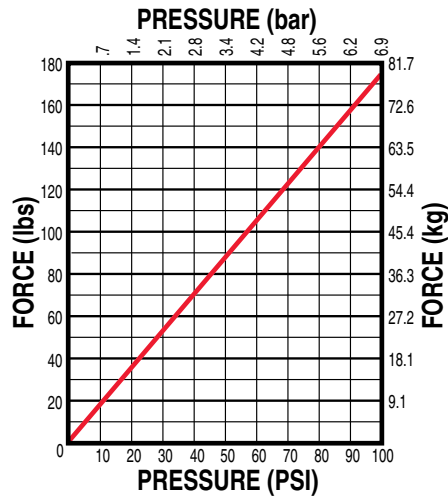

## CUSHION DATA

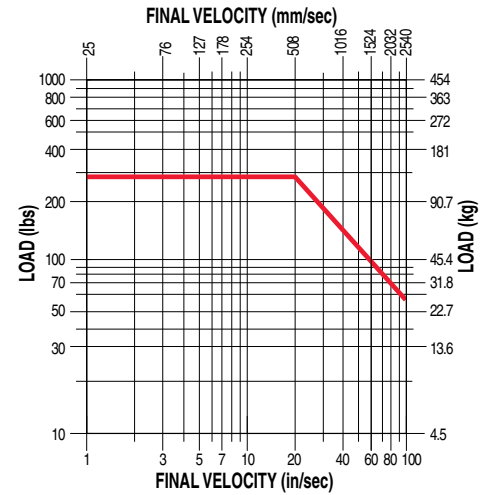

## TUBING SPECIFICATIONS

		CC15	
DEAD LENGTH*	in	3.40	
	mm	86.4	
WALL THICKNESS	in	0.125	
	mm	3.175	
MATERIAL		Alum. or Steel	
TUBE SUPPORT SPAN	Alum.	in	84
	Steel	in	90
		mm	2286

\*Add to stroke length to determine overall length

## CABLE SPECIFICATIONS

		CC05	
WIRE DIA	in	0.0937	
	mm	2.380	
NYLON O.D.	in	0.187	
	mm	4.750	
STRAND CONFIGURATION		7 x 7	
TENSILE STRENGTH	lb	920	
	kg	417.30	
PROOF-LOAD TORQUE	in-lb	45	
	N-m	5.08	
PRETENSIONING TORQUE	in-lb	8	
	N-m	0.90	

## DIMENSIONS

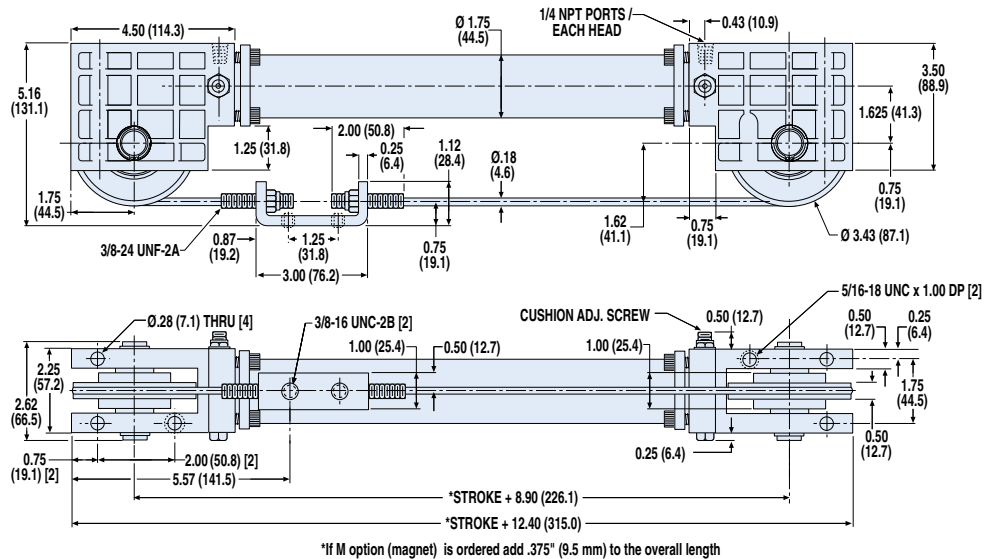



# Double Acting Cable Cylinder - CC20, CC25

OVERALL UNIT SPECIFICATIONS				
		CC20	CC25	
BORE SIZE	in	2.00	2.50	
	mm	50.8	63.5	
MAX STROKE	in	281	281	
	mm	7137	7137	
BASE WEIGHT	Alum.	lb	12.44	12.9
		kg	5.64	5.85
	Steel	lb	12.9	13.48
		kg	5.85	6.11
WEIGHT PER UNIT OF STROKE	Alum.	lb per in	0.083	0.103
		g per mm	1.482	1.839
	Steel	lb per in	0.236	0.292
		g per mm	4.214	5.214
MAX PRESSURE	PSI	200	200	
	bar	13.8	13.8	
MAX TEMP	°F	140	140	
	°C	60	60	
MAX FORCE OUTPUT	lb	309	486	
	N	1376	2162	

TUBING SPECIFICATIONS				
		CC20	CC25	
DEAD LENGTH*	in	3.00	3.00	
	mm	76.2	76.2	
WALL THICKNESS	in	0.125	0.125	
	mm	3.175	3.175	
MATERIAL		Alum or Steel	Alum or Steel	
TUBE SUPPORT SPAN	Alum.	in	90	96
		mm	2286	2438
	Steel	in	96	108
		mm	2438	2743

\*Add to stroke length to determine overall length

CABLE SPECIFICATIONS			
		CC20	CC25
WIRE DIA	in	0.125	0.125
	mm	3.175	3.175
NYLON O.D.	in	0.250	0.250
	mm	6.350	6.350
STRAND CONFIGURATION		7 x 19	7 x 19
TENSILE STRENGTH	lb	2000	2000
	kg	907.18	907.18
PROOF-LOAD TORQUE	in-lb	115	115
	N-m	12.99	12.99
PRETENSIONING TORQUE	in-lb	46.0	73.0
	N-m	5.20	8.25

## THEORETICAL FORCE vs PRESSURE

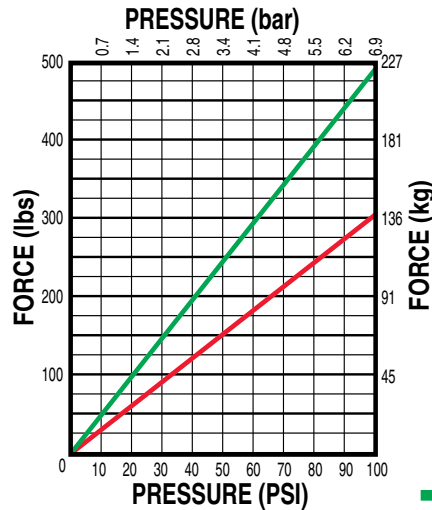

## CUSHION DATA

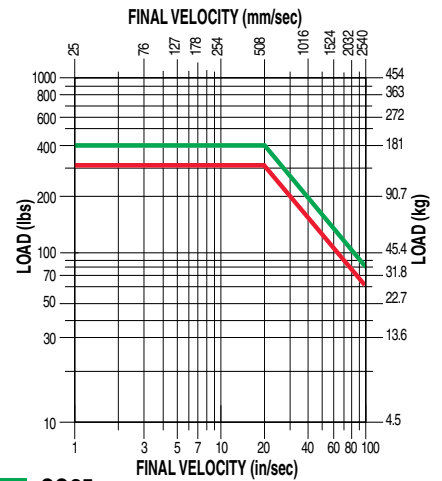

## DIMENSIONS

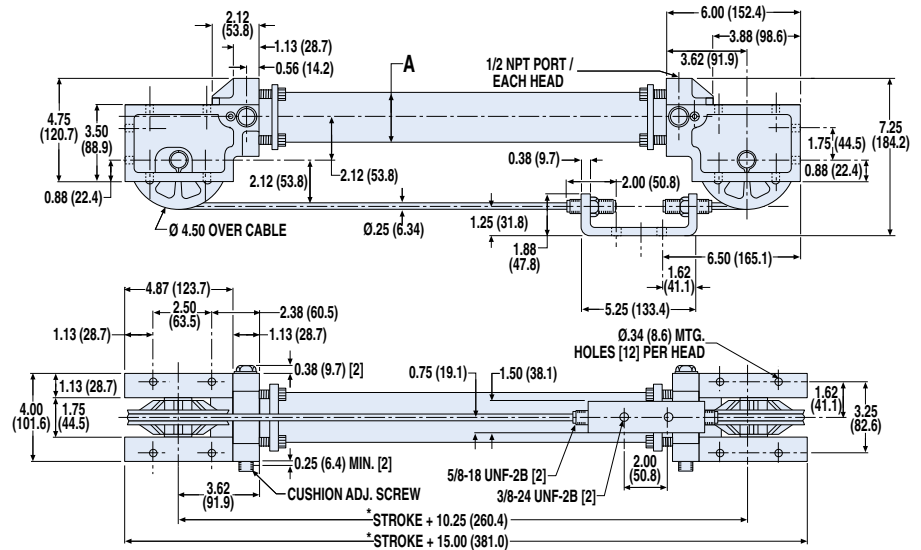

\*If M option (magnet) is ordered add 0.375" (9.5 mm) to the overall length

Dimensions in inches, in parentheses ( ) dimensions in millimeters

	CC20	CC25
A	$\varnothing 2.25$ (57.2)	$\varnothing 2.75$ (69.9)



# Double Acting Cable Cylinder - CC30, CC40, CC52

OVERALL UNIT SPECIFICATIONS					
		CC30	CC40	CC52	
BORE SIZE	in	3.00	4.00	2.50	
	mm	76.2	101.6	63.5	
MAX STROKE	in	280	279	280	
	mm	7112	7087	7112	
BASE WEIGHT	Alum.	lb	18.69	20.75	12.44
		kg	8.48	9.41	5.64
	Steel	lb	19.45	22.09	12.9
		kg	8.82	10.02	5.85
WEIGHT PER UNIT OF STROKE	Alum.	lb per in	0.12	0.159	0.081
		g per mm	2.143	2.839	1.446
	Steel	lb per in	0.334	0.459	0.236
		g per mm	5.965	8.197	4.214
MAX PRESSURE	PSI	200	100	500	
	bar	13.8	6.9	34.5	
MAX TEMP	°F	140	140	140	
	°C	60	60	60	
MAX FORCE OUTPUT	lb	1398.4	1248.9	1532.4	
	N	6220	5555	6816	

TUBING SPECIFICATIONS					
		CC30	CC40	CC52	
DEAD LENGTH*	in	3.50	4.50	3.00	
	mm	88.9	114.3	76.2	
WALL THICKNESS	in	0.125	0.125	0.125	
	mm	3.175	3.175	3.175	
MATERIAL		Alum or Steel	Alum or Steel	Alum or Steel	
TUBE SUPPORT SPAN	Alum.	in	102	108	96
		mm	2591	2743	2438
	Steel	in	120	132	96
		mm	3048	3353	2438

\*Add to stroke length to determine overall length

CABLE SPECIFICATIONS				
		CC30	CC40	CC52
WIRE DIA	in	0.187	0.187	0.187
	mm	4.750	4.750	4.750
NYLON O.D.	in	0.312	0.312	0.312
	mm	7.925	7.925	7.925
STRAND CONFIGURATION		7 x 19	7 x 19	7 x 19
TENSILE STRENGTH	lb	4200	4200	4200
	kg	1905	1905	1905
PROOF-LOAD TORQUE	in-lb	210	210	210
	N-m	23.73	23.73	23.73
PRETENSIONING TORQUE	in-lb	105	187.5	115
	N-m	11.86	21.19	12.99

## THEORETICAL FORCE vs PRESSURE

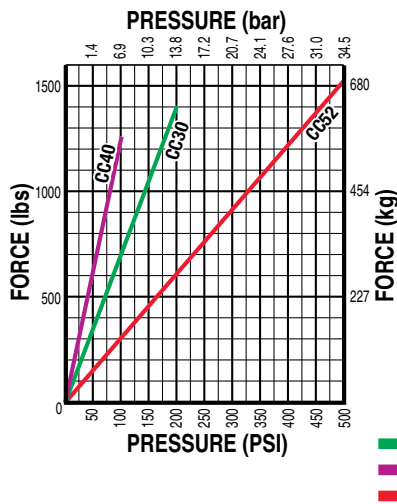

## CUSHION DATA

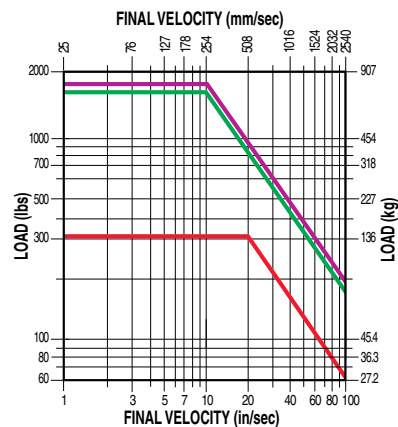

## DIMENSIONS

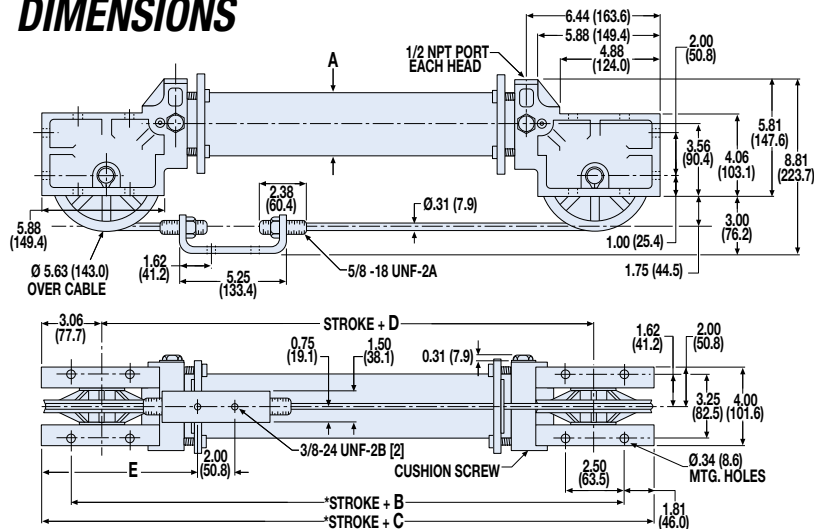

	CC30	CC40	CC52
A	Ø3.25 (82.6)	Ø4.25 (108.0)	Ø2.25 (57.2)
B	13.87(352.3)	14.87 (377.7)	13.87 (352.3)
C	17.50 (444.5)	18.50 (469.9)	17.50 (444.5)
D	11.38 (289.1)	12.38 (314.5)	11.38 (289.1)
E	7.75 (196.9)	8.25 (209.6)	7.75 (196.9)

\*If M option (magnet) is ordered add .375" (9.5 mm) to the overall length

Dimensions in inches, in parentheses ( ) dimensions in millimeters



# Double Acting Cable Cylinder - CC50

## OVERALL UNIT SPECIFICATIONS

		CC50	
BORE SIZE	in	5.00	
	mm	127	
MAX STROKE	in	134	
	mm	3404	
BASE WEIGHT	Alum.	lb	30.75
		kg	13.95
WEIGHT PER UNIT OF STROKE	Alum.	lb per in	0.202
		g per mm	3.786
MAX PRESSURE	PSI	100	
	bar	6.9	
MAX TEMP	°F	140	
	°C	60	
MAX FORCE OUTPUT	lb	1919	
	N	8536	

## THEORETICAL FORCE vs PRESSURE

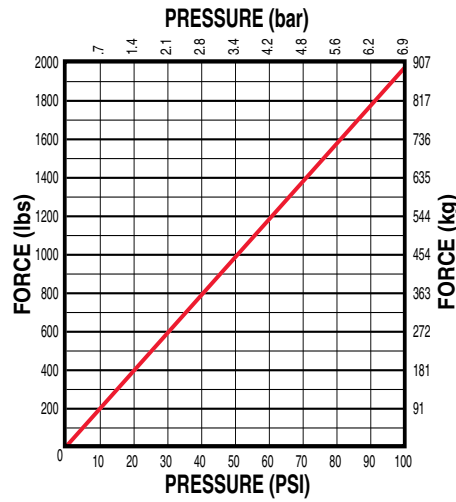

**NOTE:** The CC50 cylinder does not have cushions.

## TUBING SPECIFICATIONS

		CC50	
DEAD LENGTH*	in	6.00	
	mm	152.4	
WALL THICKNESS	in	0.125	
	mm	3.175	
MATERIAL		Alum.	
TUBE SUPPORT SPAN	Alum.	in	166.8
		mm	4237

\*Add to stroke length to determine overall length

## DIMENSIONS

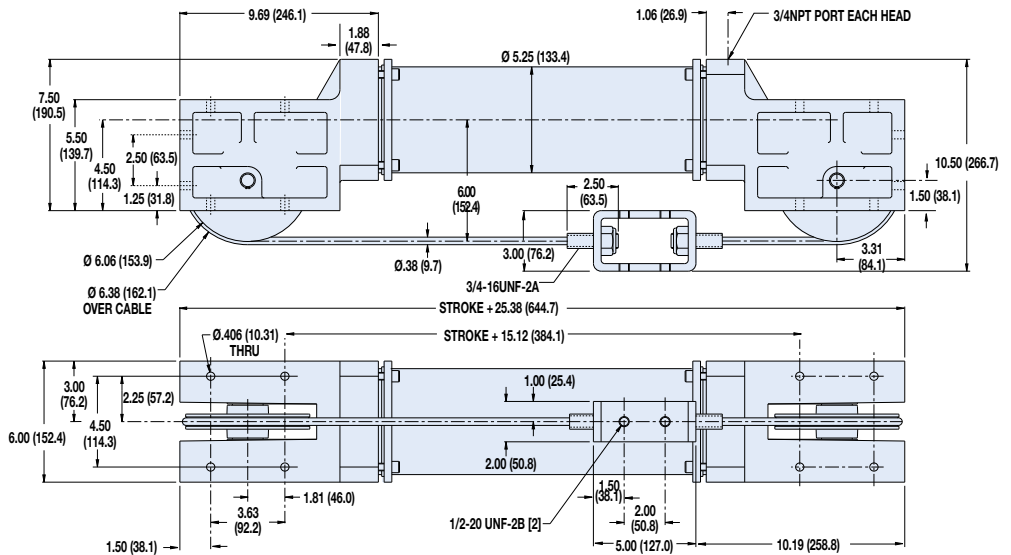

## CABLE SPECIFICATIONS

		CC50	
WIRE DIA	in	0.25	
	mm	6.350	
NYLON O.D.	in	0.375	
	mm	9.525	
STRAND CONFIGURATION		7 x 19	
TENSILE STRENGTH	lb	7000	
	kg	3175.13	
PROOF-LOAD TORQUE	in-lb	325	
	N-m	36.72	
PRETENSIONING TORQUE	in-lb	180	
	N-m	20.34	





# SA Single Acting Cable Cylinder - All Sizes

## FEATURES AND OPTIONS

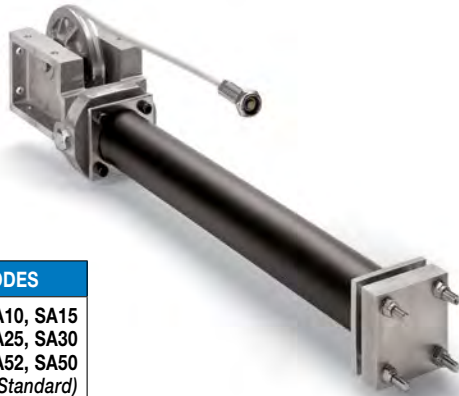

### ORDER CODES

SA07, SA10, SA15  
SA20, SA25, SA30  
SA40, SA52, SA50  
inch (U.S. Standard)

When a standard double-acting cable cylinder is not necessary in vertical applications, Tolomatic single-acting cable cylinders provide a cost savings advantage. Ideal for vertical lifting applications, these cylinders may be positioned horizontally and still achieve a vertical movement. Tolomatic single-acting cylinders are available in 8 bore sizes ranging from 3/4-inch to 5 inches with optional switches.

SA OPTIONS	Order Code	Page	SA07	SA10	SA15	SA20	SA25	SA30	SA40	SA52	SA50
Switches (DC Reed & Triac)	(several)	cc_28	OP	OP	OP	OP	OP	OP	OP	OP	OP
Aluminum Tube			ST	ST	ST	ST	ST	ST	ST	ST	ST
Steel Tube (Switches NOT available)	S		-	OP	OP	OP	OP	OP	OP	OP	OP
Seals of Viton® Material	V		OP	OP	OP	OP	OP	OP	OP	OP	OP
3 Ported Heads	HG		OP	OP	OP	OP	OP	OP	OP	OP	OP
<b>MORE INFORMATION</b>	<b>Page</b>										
Application Guidelines	cc_36		ST	ST	ST	ST	ST	ST	ST	ST	ST
Cushion Needle Adjustment	cc_38		ST	ST	ST	ST	ST	ST	ST	ST	ST
Ordering	cc_40		ST	ST	ST	ST	ST	ST	ST	ST	ST
Selection	cc_30		ST	ST	ST	ST	ST	ST	ST	ST	ST
<b>STANDARD FEATURE</b>	<b>Page</b>										
Fixed Orifice Cushions	cc_38		ST	ST	-	-	-	-	-	-	-
Adjustable Cushions	cc_38		-	-	ST	ST	ST	ST	ST	ST	ST
Single Ported Head			ST	ST	ST	ST	ST	ST	ST	ST	ST

- = Not Available      OP = Optional      ST = Standard

 **NOTE:** See corresponding CC (double acting cable cylinder) for performance, tubing and cable specifications Page CC\_7 to Page CC\_11

# Single Acting Cable Cylinder - SA07, SA10, SA15

3D CAD AVAILABLE AT  
WWW.TOLOMATIC.COM



## SA07, SA10

### DIMENSIONS

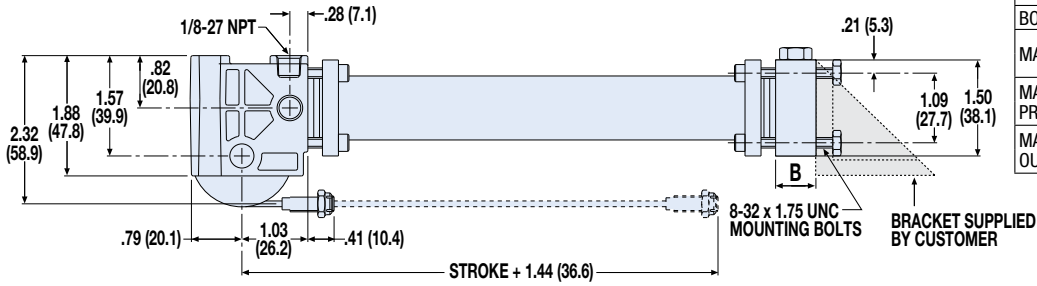

OVERALL UNIT SPECIFICATIONS			
		SA07	SA10
BORE SIZE	in	0.75	1.00
MAX STROKE	in	138	282
	mm	3505	7163
MAX PRESSURE	PSI	100	100
	bar	6.9	6.9
MAX FORCE OUTPUT	lb	43.5	77.9
	N	193.5	346.5

NOTE: Additional specifications Page CC\_7

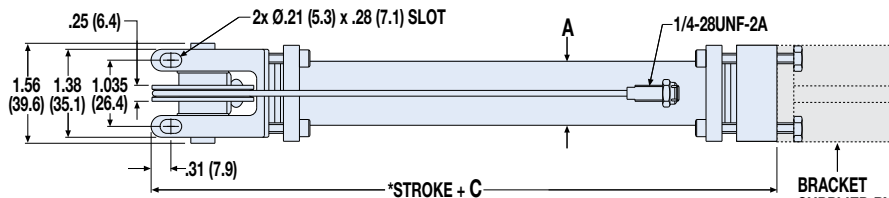

	SA07	SA10
A	Ø 1.00 (25.4)	Ø 1.25 (31.8)
B	0.50 (12.7)	0.63 (16.0)
C	3.62 (92.0)	3.81 (96.8)
D	1.46 (37.1)	1.62 (41.2)

Dimensions in inches, in parentheses ( ) dimensions in millimeters

\*If M option (magnet) is ordered add D to the overall length

BRACKET SUPPLIED BY CUSTOMER

## SA15

### DIMENSIONS

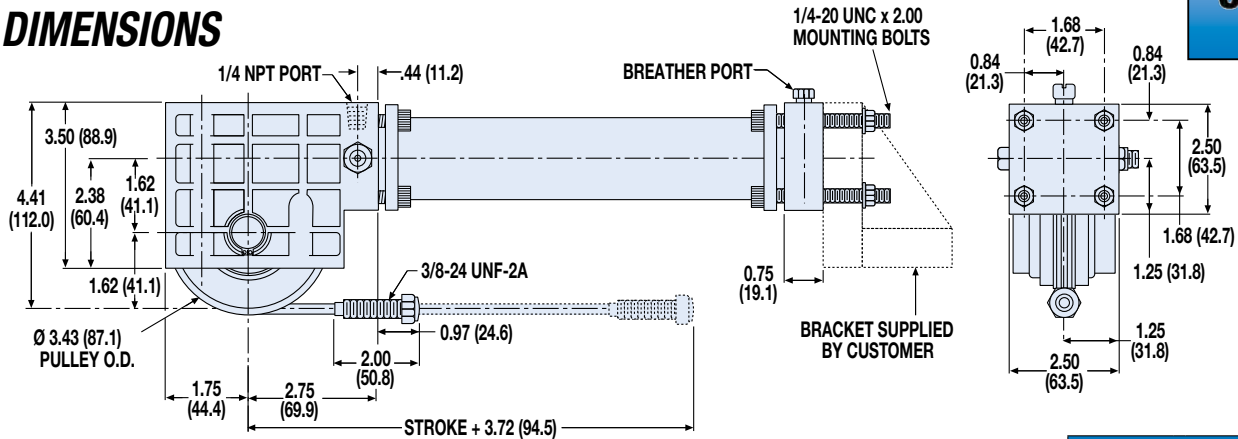

OVERALL UNIT SPECIFICATIONS			
		SA15	
BORE SIZE	in	1.50	
MAX STROKE	in	280	
	mm	7112	
MAX PRESSURE	PSI	100	
	bar	6.9	
MAX FORCE OUTPUT	lb	174	
	N	774.0	

NOTE: Additional specifications Page CC\_8

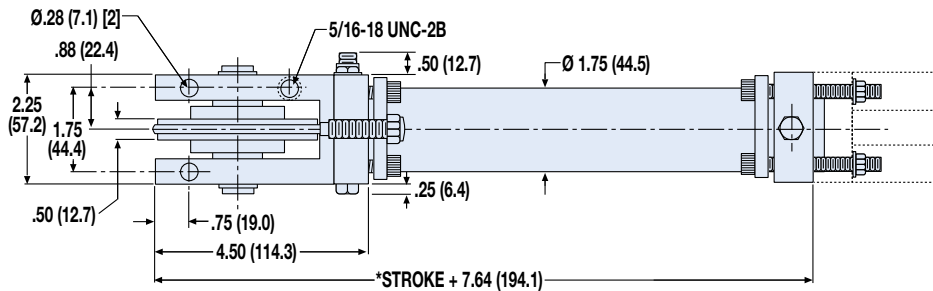

Dimensions in inches, in parentheses ( ) dimensions in millimeters

\*If M option (magnet) is ordered add .375" (9.5 mm) to the overall length

# Single Acting Cable Cylinder - SA20, SA25, SA30, SA40, SA52

3D CAD AVAILABLE AT  
WWW.TOLOMATIC.COM



## SA20, SA25

### DIMENSIONS

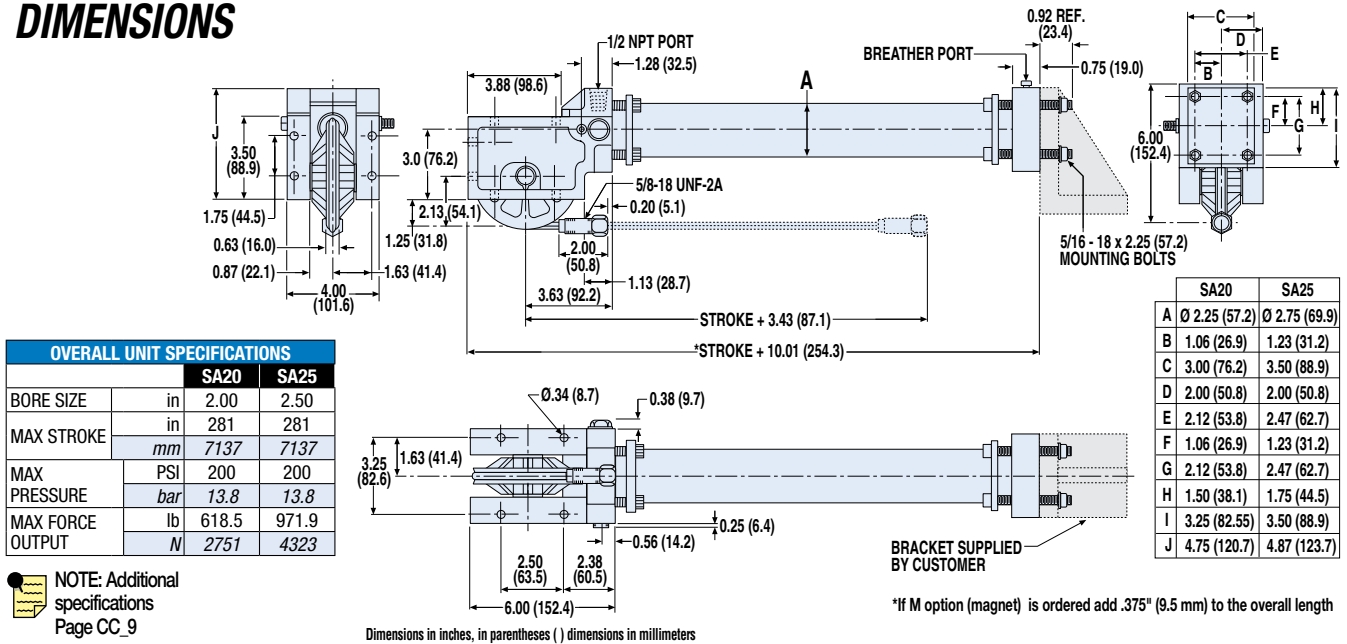

## SA30, SA40, SA52

### DIMENSIONS

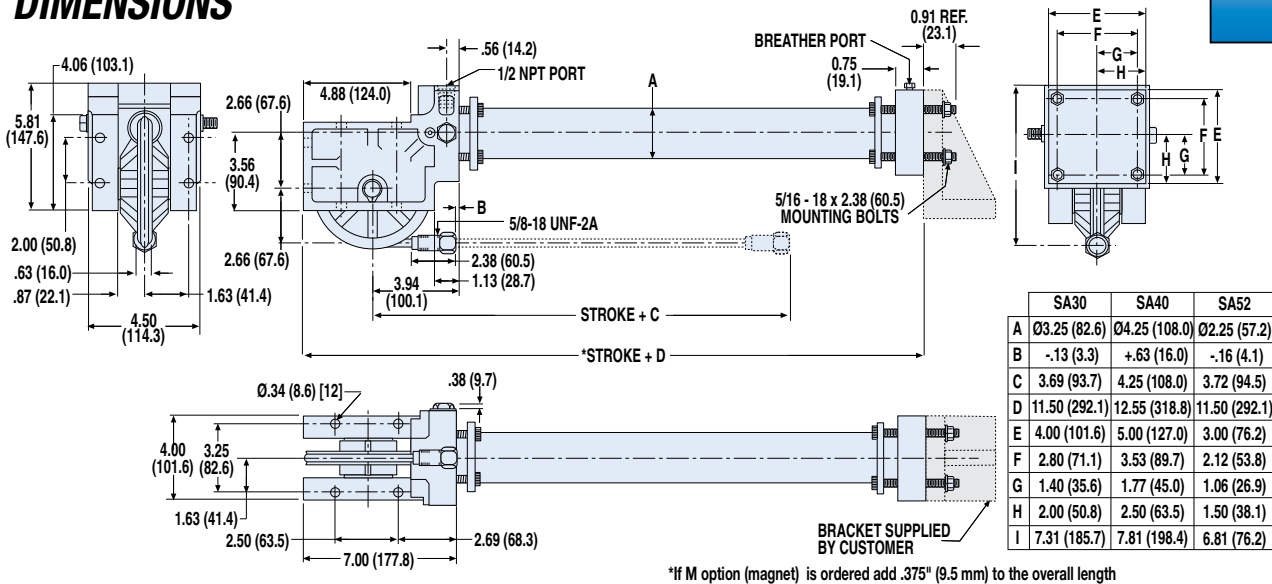



# Single Acting Cable Cylinder - SA50



SA50

## DIMENSIONS

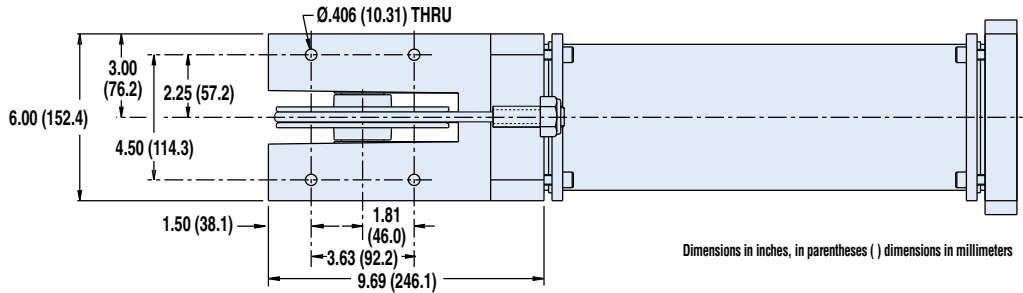
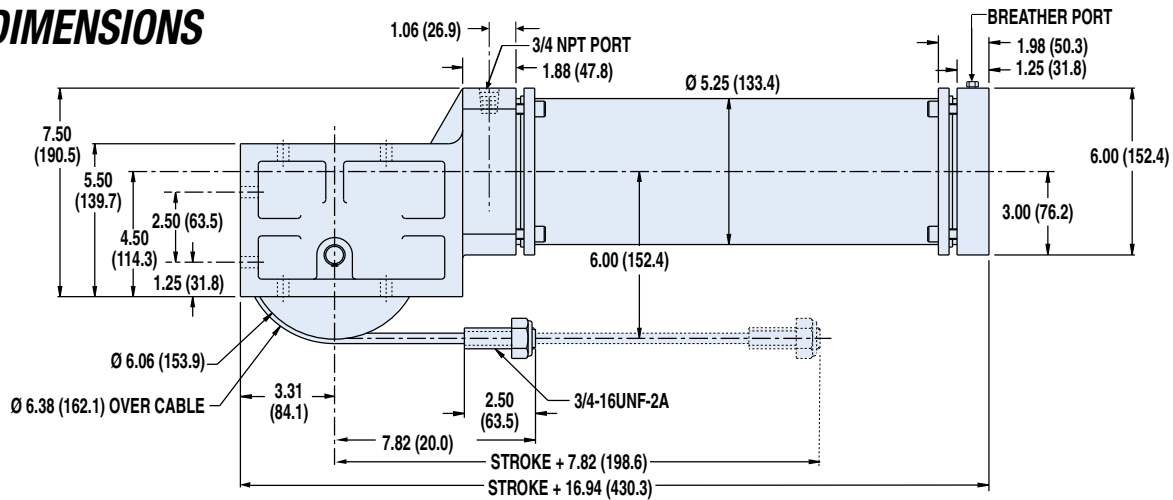

Dimensions in inches, in parentheses ( ) dimensions in millimeters

### OVERALL UNIT SPECIFICATIONS

		SA50
BORE SIZE	in	5.00
	in	134
MAX STROKE	mm	3404
MAX PRESSURE	PSI	100
	bar	6.9
MAX FORCE	lb	1919
OUTPUT	N	8536

NOTE: Additional specifications Page CC\_11

# Double Purchase Cable Cylinder - All Sizes

## FEATURES AND OPTIONS



### ORDER CODES

**DP15, DP20, DP25**  
**DP30, DP40, DP52**  
*inch (U.S. Standard)*

The Tolomatic double purchase cable cylinder doubles the velocity and stroke capacity of double-acting cylinders without increasing space requirements. Available in 5 bore sizes, these cylinders can extend stroke lengths up to 120 feet with considerable cost-saving advantages and they can be placed away from hostile environments.

 NOTE: Pulleys and cables used on double purchase cable cylinders are always from the next smaller model size.

 NOTE: For double purchase applications, select a bore size that will accommodate twice the load force.

DP OPTIONS	Order Code	Page	DP15	DP20	DP25	DP30	DP40	DP52
Auto Tensioner w/ one 1" Stroke Unit	HI, HJ	cc_22	OP	OP	OP	OP	OP	OP
Auto Tensioner w/ two 1" Stroke Units	HI, HJ	cc_22	OP	OP	OP	OP	OP	OP
Auto Tensioner w/ one 2" Stroke Unit	HK,HL	cc_22	-	OP	OP	OP	OP	OP
Auto Tensioner w/ two 2" Stroke Units	HK,HL	cc_22	-	OP	OP	OP	OP	OP
Caliper Disc Brake	HM, HN	cc_25	OP	OP	OP	OP	OP	OP
Switches (DC Reed & Triac)	(several)	cc_28	OP	OP	OP	OP	OP	OP
Aluminum Tube			ST	ST	ST	ST	ST	ST
Steel Tube (Switches NOT available)	S		OP	OP	OP	OP	OP	OP
Seals of Viton® Material	V		OP	OP	OP	OP	OP	OP
3 Ported Heads	HG		OP	OP	OP	OP	OP	OP
<b>MORE INFORMATION</b>	<b>Page</b>							
Application Guidelines	cc_36		ST	ST	ST	ST	ST	ST
Cushion Needle Adjustment	cc_38		ST	ST	ST	ST	ST	ST
Ordering	cc_40		ST	ST	ST	ST	ST	ST
Selection	cc_30		ST	ST	ST	ST	ST	ST
Caliper Disc Brake Option Selection	cc_32		OP	OP	OP	OP	OP	OP
<b>STANDARD FEATURE</b>	<b>Page</b>							
Fixed Orifice Cushions	cc_38		-	-	-	-	-	-
Adjustable Cushions	cc_38		ST	ST	ST	ST	ST	ST
Single Ported Head			ST	ST	ST	ST	ST	ST

- = Not Available      OP = Optional      ST = Standard

 NOTE: See corresponding CC (double acting cable cylinder) for performance, tubing and cable specifications Page CC\_8 to Page CC\_10

# Double Purchase Cable Cylinder - DP15, DP20, DP25

3D CAD AVAILABLE AT  
WWW.TOLOMATIC.COM



## DP15

### DIMENSIONS

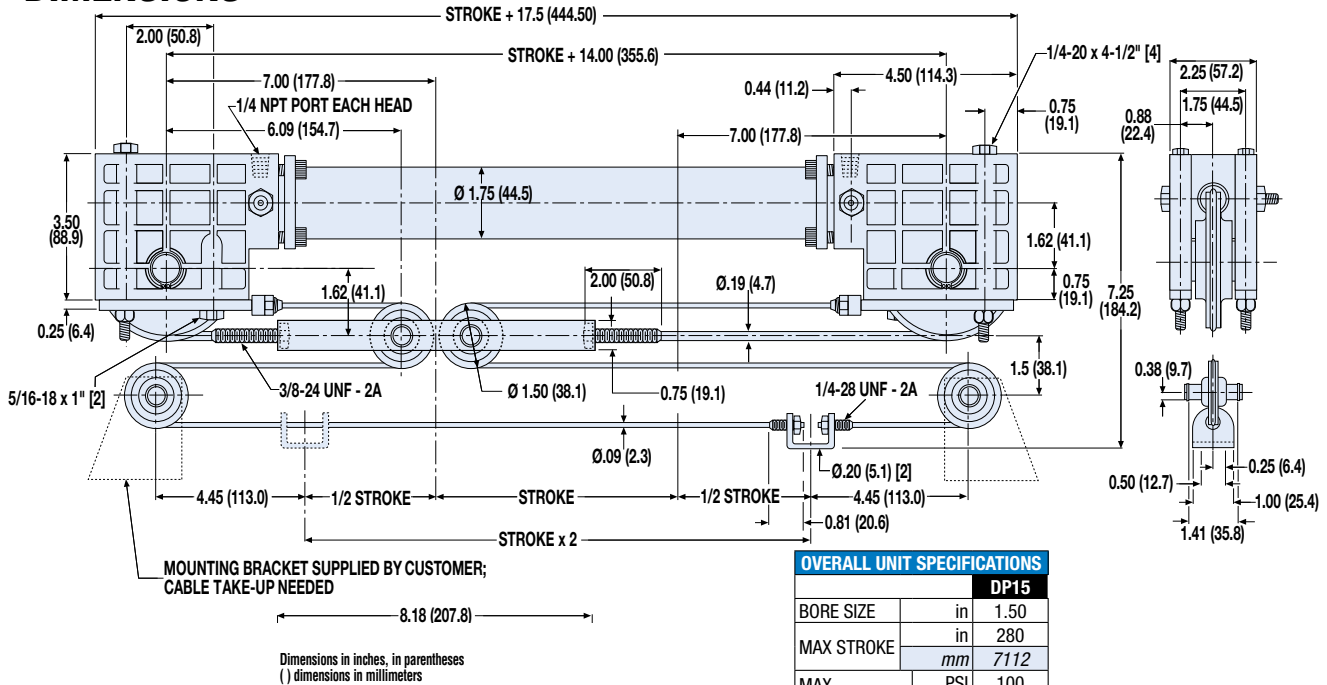

#### OVERALL UNIT SPECIFICATIONS

		DP15
BORE SIZE	in	1.50
MAX STROKE	in	280
	mm	7112
MAX PRESSURE	PSI	100
	bar	6.9
MAX FORCE OUTPUT	lb	174
	N	774.0

NOTE: Additional specifications Page CC\_8

## DP20, DP25

### DIMENSIONS

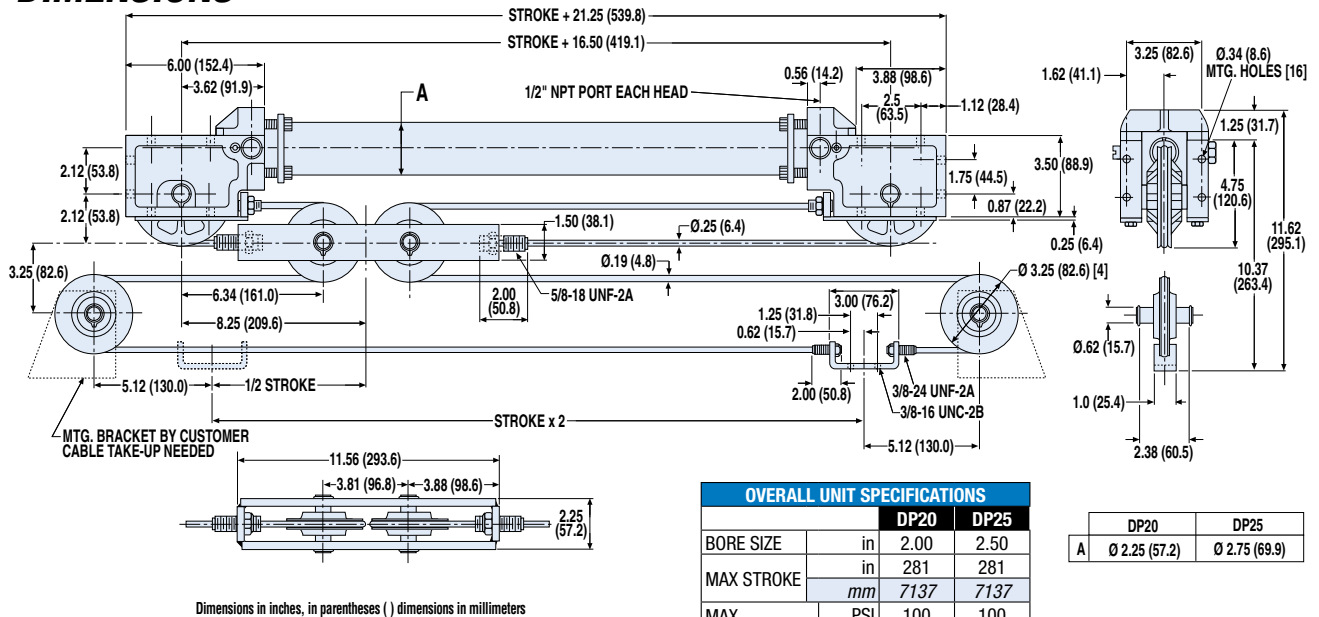

#### OVERALL UNIT SPECIFICATIONS

		DP20	DP25
BORE SIZE	in	2.00	2.50
	in	281	281
MAX STROKE	mm	7137	7137
	PSI	100	100
MAX PRESSURE	bar	6.9	6.9
	lb	618.5	971.9
MAX FORCE OUTPUT	N	2751	4323

	DP20	DP25
A	Ø 2.25 (57.2)	Ø 2.75 (69.9)

NOTE: Additional specifications Page CC\_9



# Double Purchase Cable Cylinder - DP30, DP40, DP52

DP30, DP40, DP52



## DIMENSIONS

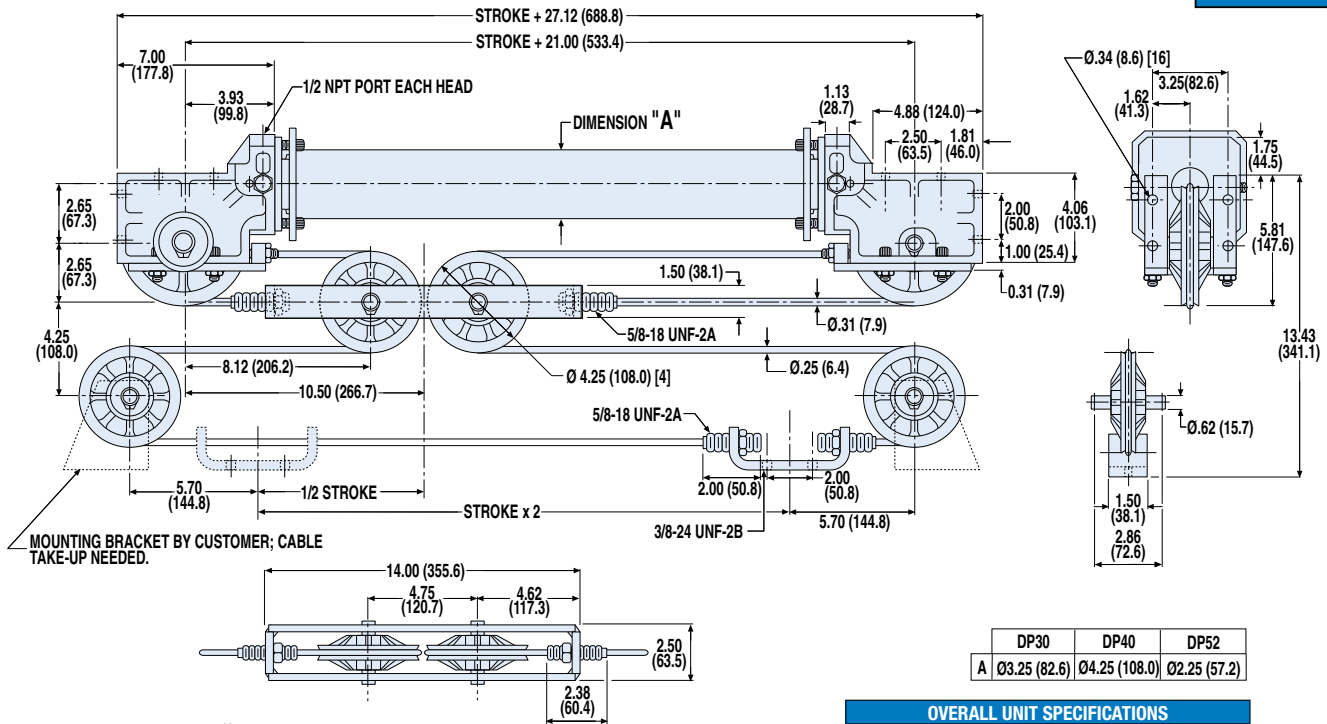

Dimensions in inches, in parentheses ( ) dimensions in millimeters

NOTE: Additional specifications Page CC\_10

OVERALL UNIT SPECIFICATIONS			
	DP30	DP40	DP52
BORE SIZE	in 3.00	4.00	2.50
MAX STROKE	in 280	279	280
	mm 7112	7087	7112
MAX PRESSURE	PSI 200	100	500
	bar 13.8	6.9	34.5
MAX FORCE OUTPUT	lb 1398.4	1248.9	1532.4
	N 6220	5555	6816

# TC Track Cable Cylinder - All Sizes

## FEATURES AND OPTIONS

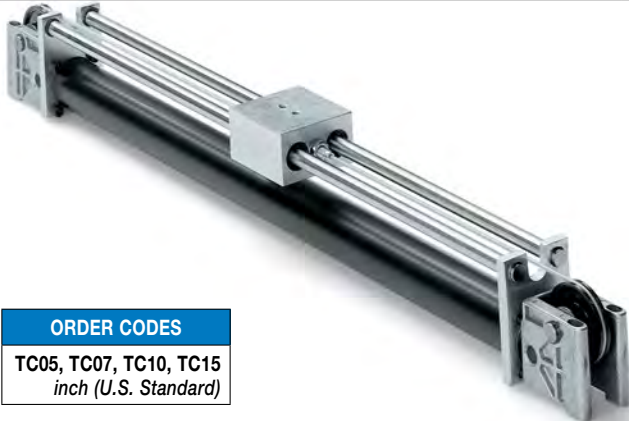

**ORDER CODES**  
**TC05, TC07, TC10, TC15**  
*inch (U.S. Standard)*

Tolomatic track cable cylinders provide a pre-packaged, pre-engineered guide and support system for greater bearing surface and larger load capacities. An aluminum bearing block guides and supports loads on precision linear ball bearings with hardened ground steel shafts. Available in 4 bore sizes with automatic tensioners and caliper disc brake options on selected models.

TC OPTIONS	Order Code	Page	TC05	TC07	TC10	TC15
Auto Tensioner w/ one 1" Stroke Unit	HI, HJ	cc_22	-	OP	OP	OP
Auto Tensioner w/ two 1" Stroke Units	HI, HJ	cc_22	-	OP	OP	OP
Caliper Disc Brake	HM, HN	cc_25	-	-	-	OP
Switches (DC Reed & Triac)	(several)	cc_28	OP	OP	OP	OP
Aluminum Tube			ST	ST	ST	ST
Steel Tube (Switches NOT available)	S		-	-	OP	OP
Seals of Viton® Material	V		-	OP	OP	OP
3 Ported Heads	HG		OP	OP	OP	OP
<b>MORE INFORMATION</b>	<b>Page</b>					
Application Guidelines	cc_36		ST	ST	ST	ST
Cushion Needle Adjustment	cc_38		-	ST	ST	ST
Ordering	cc_40		ST	ST	ST	ST
Selection	cc_30		ST	ST	ST	ST
Caliper Disc Brake Option Selection	cc_32		-	-	-	OP
<b>STANDARD FEATURE</b>	<b>Page</b>					
Fixed Orifice Cushions	cc_38		-	ST	ST	-
Adjustable Cushions	cc_38		-	-	-	ST
Single Ported Head			ST	ST	ST	ST

- = Not Available      OP = Optional      ST = Standard

 **NOTE:** See corresponding CC (double acting cable cylinder) for performance, tubing and cable specifications Page CC\_7 to Page CC\_8

# TC Track Cable Cylinder - TC05, TC07, TC10

## LOAD WEIGHT vs STROKE TC05, TC07, TC10 (3/8" Dia. Rods at 0.30" Deflection)

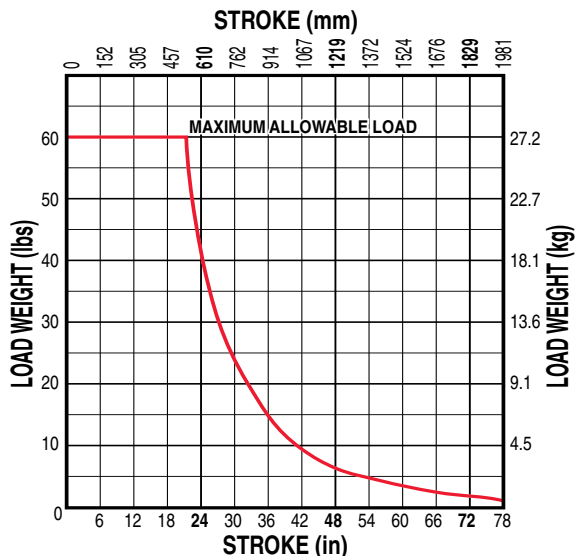

**NOTE:** Rod deflection must not exceed .30 inches

OVERALL UNIT SPECIFICATIONS				
		TC05	TC07	TC10
BORE SIZE	in	0.50	0.75	1.00
MAX STROKE	in	67.00	78.00	78.00
	mm	1701.8	1981.2	1981.2
MAX PRESSURE	PSI	100	100	100
	bar	6.9	6.9	6.9
MAX FORCE OUTPUT	lb	19.4	43.5	77.9
	N	86.3	193.5	346.5

**NOTE:** Additional specifications Page CC\_7

**NOTE:** Moderate bending moments are acceptable, so long as the moment load does not exceed 190 inch-pounds.

The diagrams at right, illustrate how this is calculated.

## LOAD DISTRIBUTION

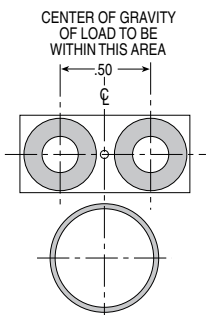

**NOTE:** Moderate bending moments are acceptable. The moment load must not exceed 30 inch-pounds for the 1/2", 3/4" and 1-inch bore cylinders.

The diagrams, illustrate how this is calculated.

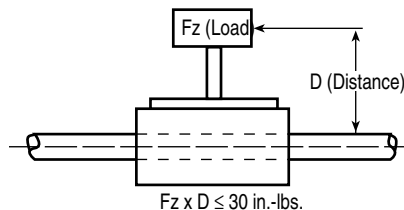

## DIMENSIONS

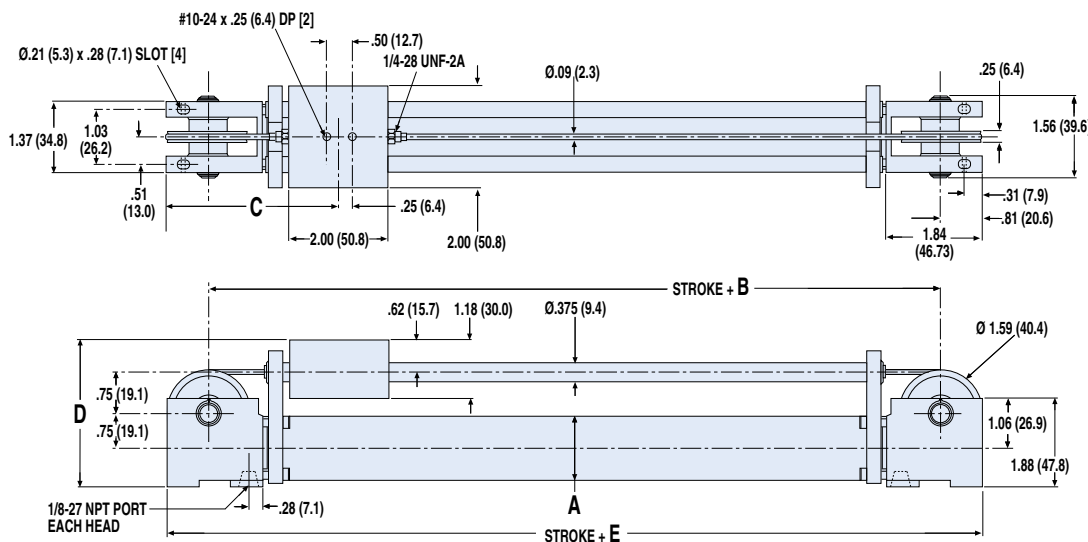

	TC05	TC07	TC10
<b>A</b>	0.625	1.000	1.250
<b>mm</b>	15.88	25.40	31.75
<b>B</b>	5.260	5.326	5.322
<b>mm</b>	133.60	135.28	135.18
<b>C</b>	3.44	3.46	3.48
<b>mm</b>	87.4	87.9	88.4
<b>D</b>	2.93	2.96	2.93
<b>mm</b>	74.4	75.2	74.4
<b>E</b>	6.870	6.936	6.932
<b>mm</b>	174.50	176.17	176.07



Dimensions in inches, in parentheses ( ) dimensions in millimeters

# TC Track Cable Cylinder - TC15

## LOAD WEIGHT vs STROKE TC15 (5/8" Dia. Rods at 0.30" Deflection)

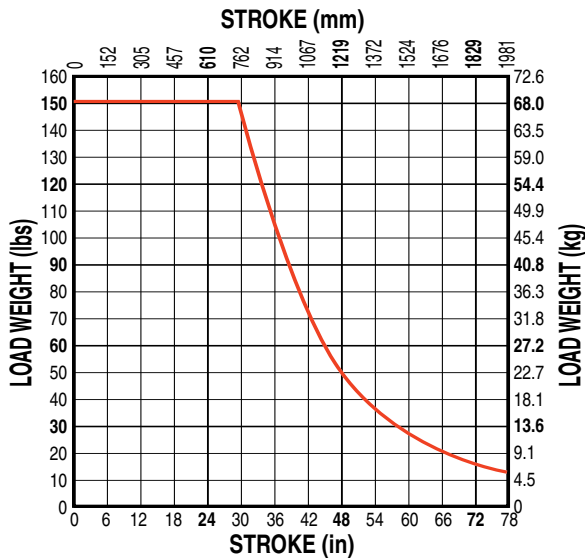

NOTE: Rod deflection must not exceed .30 inches

OVERALL UNIT SPECIFICATIONS		CC15
BORE SIZE	in	1.50
MAX STROKE	in	78
	mm	1981.2
MAX PRESSURE	PSI	100
	bar	6.9
MAX FORCE OUTPUT	lb	174
	N	774.0

NOTE: Additional specifications Page CC\_8

## LOAD DISTRIBUTION

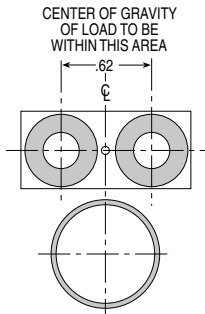

NOTE: Moderate bending moments are acceptable. The moment load must not exceed 190 inch-pounds for the 1-1/2 bore cylinder.

The diagrams, illustrate how this is calculated.

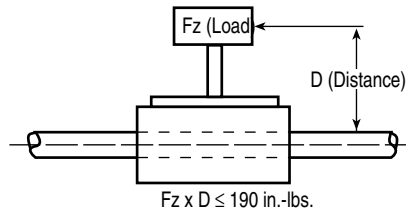

## DIMENSIONS

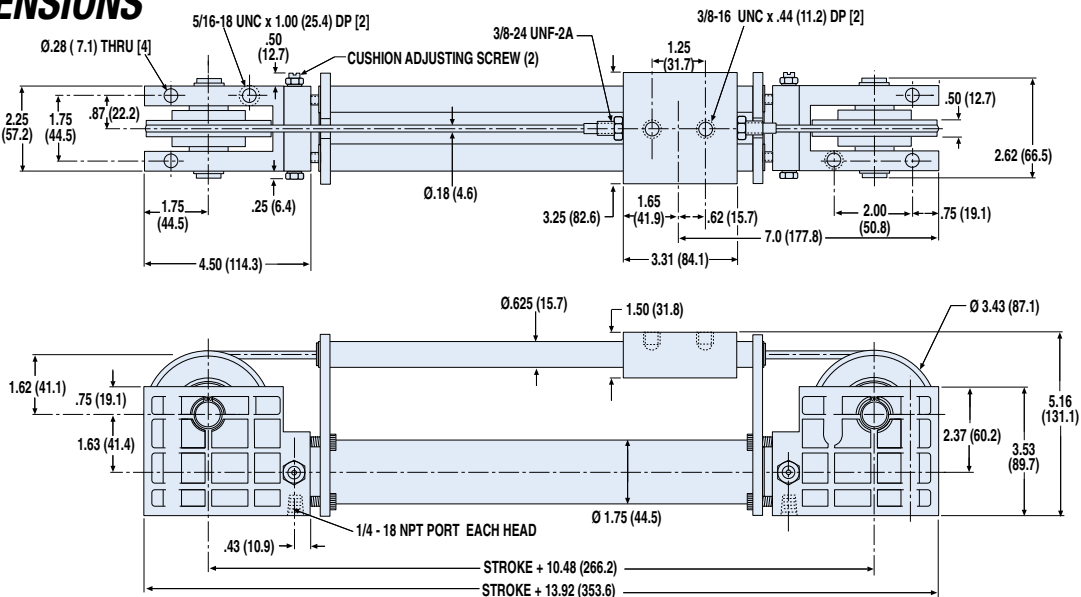



# CC Automatic Tensioner - All Sizes

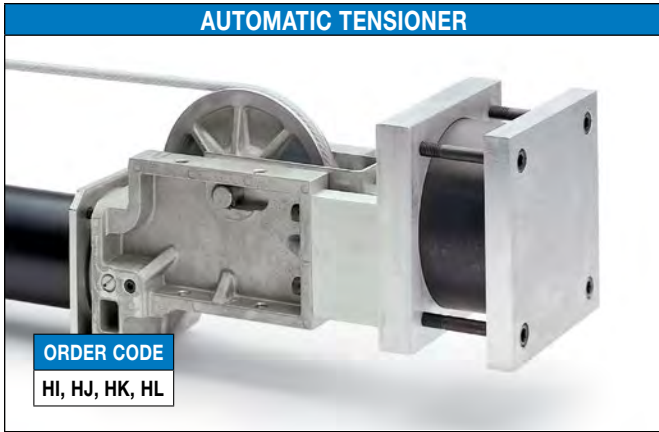

Automatic tensioners are required when a cylinder's stroke length is beyond the maximum stroke length for full manual cable adjustment for that bore size. The AT unit keeps the cable rigid and ensures maximum service life of both the cable and gland seals. AT units are also recommended for vertical lifting or severe, high-cyclic applications.

The standard automatic tensioner unit has a 1-inch stroke, providing 2 inches of cable take-up. A 2-inch stroke AT unit may be installed on a cylinder, providing 4 inches of cable take-up. Refer to the tables below for tensioner stroke options on available bore sizes.

## MAXIMUM STROKE LENGTHS FOR CYLINDERS WITH AUTO TENSIONERS

**NOTE:** A cable cylinder should be completely proof-loaded and pretensioned with either the Torque Method or the Field Method in order for the auto tensioner to achieve the maxi-

imum stroke lengths shown in the table below. (For more information on proof-loading and pretensioning, please see page cc\_36)

STROKE LENGTHS IN INCHES BASED ON CYLINDER'S MAXIMUM OPERATING PRESSURE										
STROKE OPTIONS	CC05	CC07	CC10	CC15	CC20	CC25	CC30	CC40	CC50	CC52
Auto Tensioner with one 1" stroke unit	NA	134.4	134.4	361.2	260.4	159.6	243.6	134.4	NA	266.8
Auto Tensioner with two 1" stroke units	NA	252.0	252.0	579.6	369.6	266.8	344.4	193.2	NA	327.6
Auto Tensioner with one 2" stroke unit	NA	NA	NA	NA	369.6	266.8	344.4	193.2	468.0	327.6
Auto Tensioner with two 2" stroke units	NA	NA	NA	NA	524.4	322.8	487.2	277.2	714.0	472.8

Above Dimensions in inches

STROKE LENGTHS IN METERS BASED ON CYLINDER'S MAXIMUM OPERATING PRESSURE										
STROKE OPTIONS	CC05	CC07	CC10	CC15	CC20	CC25	CC30	CC40	CC50	CC52
Auto Tensioner with one 1" stroke unit	NA	3.41	3.41	9.17	6.61	4.05	6.19	3.41	NA	6.78
Auto Tensioner with two 1" stroke units	NA	6.40	6.40	14.72	9.39	6.78	8.75	4.91	NA	8.32
Auto Tensioner with one 2" stroke unit	NA	NA	NA	NA	9.39	6.78	8.75	4.91	11.89	8.32
Auto Tensioner with two 2" stroke units	NA	NA	NA	NA	13.32	8.20	12.37	7.04	18.14	12.01

Above Dimensions in METERS

**NOTE:** Tube couplers are required on cable cylinders with strokes over 280 inches (7.11m).

Maximum stroke lengths in the above table can be extended by using the percentage of the pressure differential between the cylinder's actual operating pressure and the maximum operating pressure.

Example: If the cylinder selected is a CC15 (1 1/2-inch bore) with one 1-inch stroke AT unit:

Actual PSI: 80  
 Max. PSI: 100  
 Differential: 20%  
 $20\% \times 361.2 \text{ in. (maximum stroke)} = 72.24 \text{ in.}$   
 $72.24 \text{ in.} + 361.2 \text{ in.} = 433.44 \text{ in. (36.12 feet)}$

All AT units should be plumbed with a separate, regulated non-fluctuating pressure source which is a set percentage of the actual cylinder operating pressure. These are listed in the table at the right.

**NOTE:** When using an AT unit in an application where the cylinder is loaded in only one direction, it is recommended to have the AT unit located so the load direction of travel is away from the AT unit. On vertical applications, the AT unit should be located on the bottom.

AUTO TENSIONER PRESSURE SETTINGS	
FOR MODEL	% OF LOAD PRESSURE
CC07	22%
CC10	40%
CC15	86%
CC20	32%
CC25	51%
CC30	54%
CC40	96%
CC50	75%
CC52	24%

# CC Automatic Tensioner - CC07, CC10, CC15, CC20, CC25



## DIMENSIONS

### AT FOR CC07, CC10

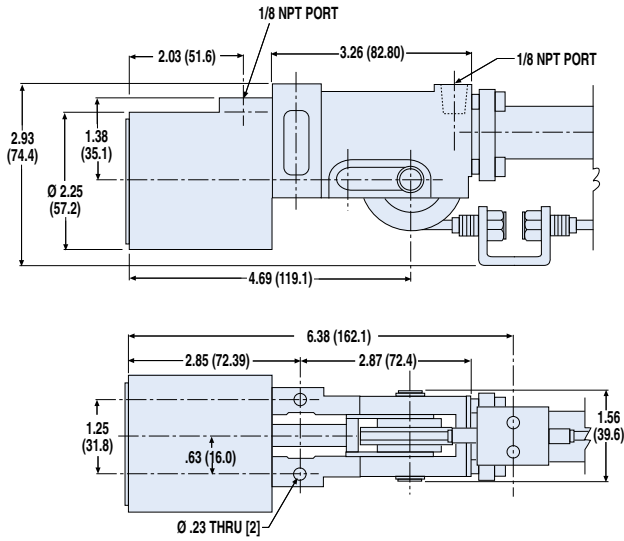

### AT FOR CC15

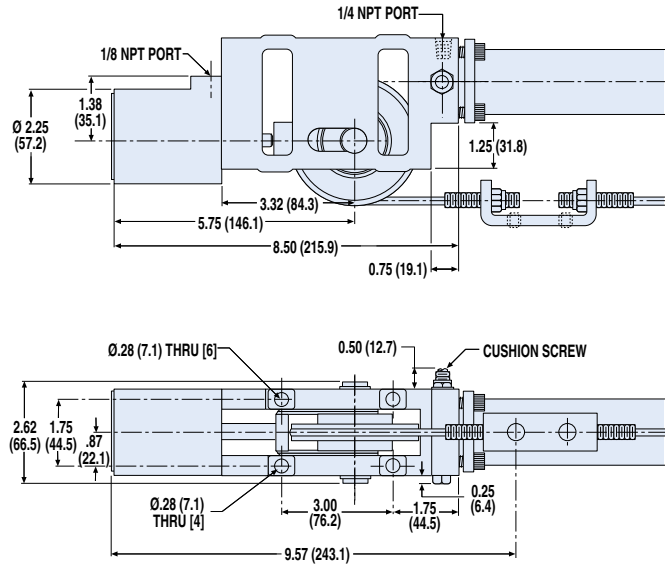

### AT FOR CC20, CC25

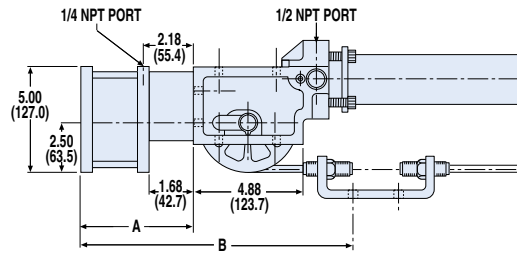

MODEL	A	B
1" Stroke Tensioner	5.66"	12.16"
2" Stroke Tensioner	6.66"	13.16"

MODEL	A	B
1" Stroke Tensioner	143.8mm	308.9mm
2" Stroke Tensioner	169.2mm	334.3mm

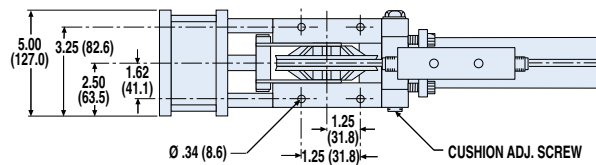

Dimensions in inches, in parentheses ( ) dimensions in millimeters

SPACE AND WEIGHT REQUIREMENTS		
MODEL	DEAD LENGTH (in)*	WEIGHT (lbs)
CC07	8.87	1.06
CC10	8.87	1.06
CC15	16.41	2.76
CC20	20.66	8.41
CC25	20.66	8.41

\*Add dead length to stroke length to determine overall cylinder length

SPACE AND WEIGHT REQUIREMENTS		
MODEL	DEAD LENGTH (mm)*	WEIGHT (kg)
CC07	225	0.48
CC10	225	0.48
CC15	417	1.25
CC20	525	3.81
CC25	525	3.81

# CC Automatic Tensioner - CC30, CC40, CC52, CC50



## DIMENSIONS

### AT FOR CC30, CC40, CC52

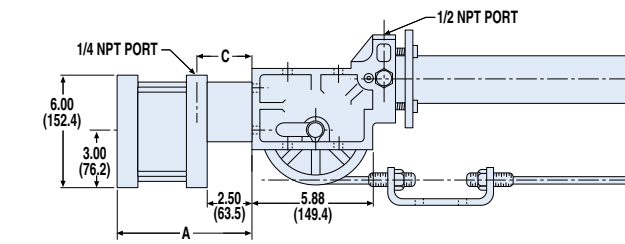

MODEL	A	B	C
1" Stroke Tensioner	6.38"	14.12"	3.01"
2" Stroke Tensioner	7.38"	15.12"	3.50"

MODEL	A	B	C
1" Stroke Tensioner	162.1mm	358.6mm	76.5mm
2" Stroke Tensioner	187.5mm	384.0mm	88.9mm

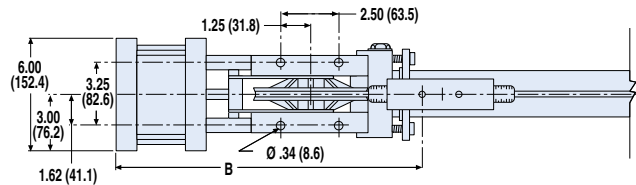

Dimensions in inches, in parentheses ( ) dimensions in millimeters

SPACE AND WEIGHT REQUIREMENTS		
MODEL	DEAD LENGTH (in)*	WEIGHT (lbs)
CC30	23.88	14.36
CC40	24.88	14.36
CC52	23.88	14.36
CC50	33.75	23.68

\*Add dead length to stroke length to determine overall cylinder length

SPACE AND WEIGHT REQUIREMENTS		
MODEL	DEAD LENGTH (mm)*	WEIGHT (kg)
CC30	607	6.51
CC40	632	6.51
CC52	607	6.51
CC50	857	10.74

# CC Cylinder/Brake Combinations - All Sizes

## CALIPER DISC BRAKE



ORDER CODE

HM, HN

Caliper disc brakes can be used to add holding force in horizontal applications and aid in deceleration at the end of stroke. Caliper disc brakes must be used with an automatic tensioner to function properly. See page CC\_32 for selection information and braking formulae.

NOTE: Tolomatic's H20DARC is used on all available models. See part numbers below:

	CC15	CC20	CC25	CC30	CC40	CC52
Brake Number	0728-0010	0728-0010	0728-0010	0728-0010	0728-0010	0728-0010
Disc & Hub No.	0801-0008	0801-0010	0801-0010	0801-0010	0801-0010	0801-0010

See catalog 9900-4009 for detailed information on brakes and discs.

### DYNAMIC TORQUE H-20 BRAKE with 6-5/16" DISC (FOR CC15, CC20, CC25, CC30, CC40, CC52)

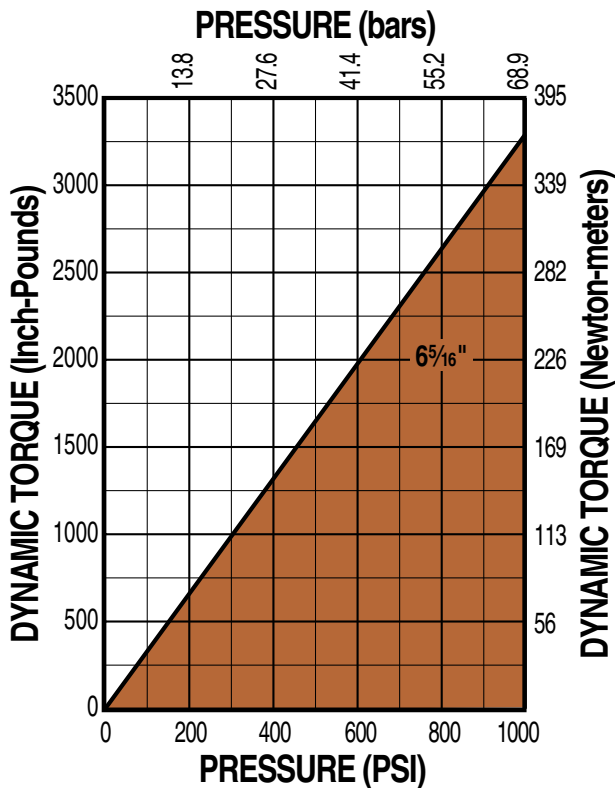

### STATIC TORQUE H-20 BRAKE with 6-5/16" DISC (FOR CC15, CC20, CC25, CC30, CC40, CC52)

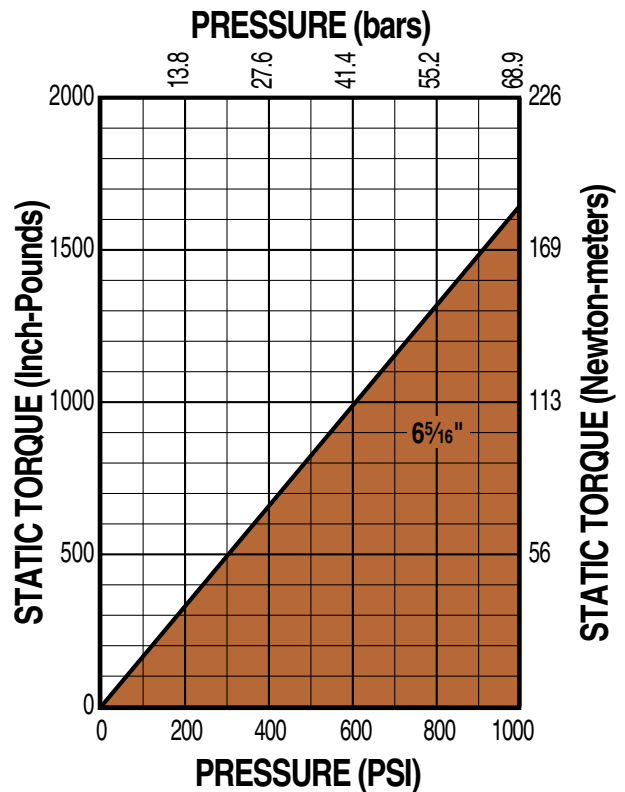



## DIMENSIONS

### CYLINDER/ BRAKE COMBINATION FOR CC15

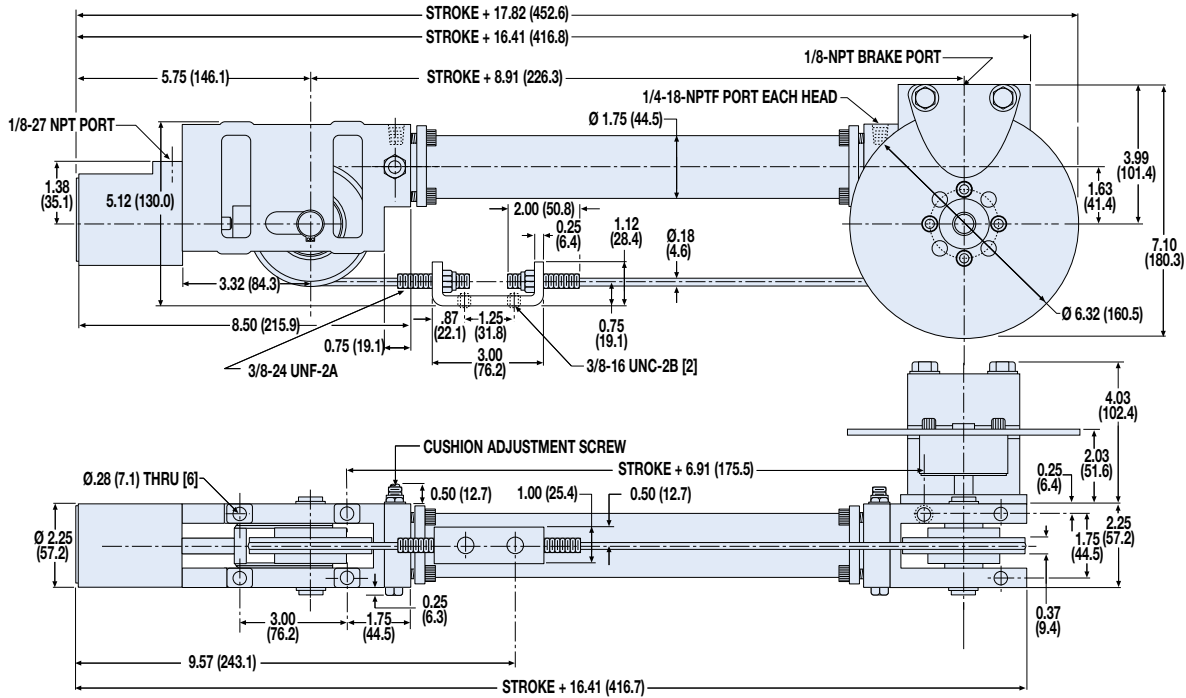

### CYLINDER/ BRAKE COMBINATION FOR CC20, CC25

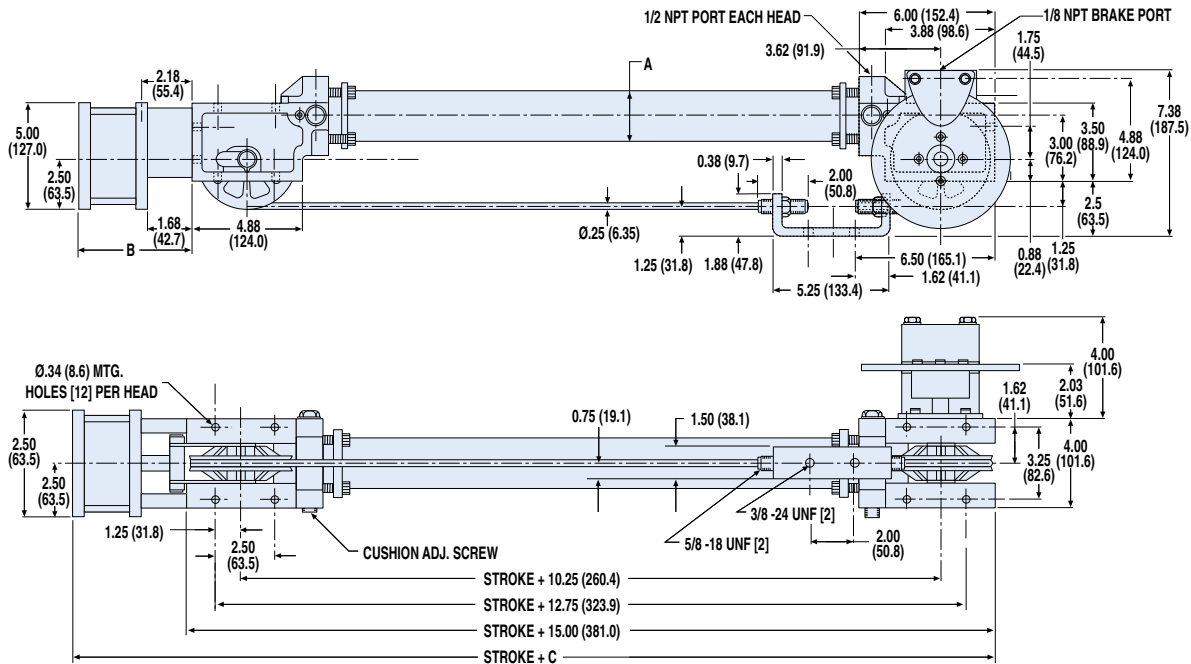

MODEL	A	B	C
CC20 w/ 1" Stroke Tensioner	Ø 2.25"	5.66"	20.86"
CC20 w/ 2" Stroke Tensioner	Ø 2.25"	6.66"	22.15"
CC25 w/ 1" Stroke Tensioner	Ø 2.75"	5.66"	20.66"
CC25 w/ 2" Stroke Tensioner	Ø 2.75"	6.66"	22.15"

MODEL	A	B	C
CC20 w/ 1" Stroke Tensioner	Ø 57.2mm	143.8mm	524.7mm
CC20 w/ 2" Stroke Tensioner	Ø 57.2mm	169.2mm	561.6mm
CC25 w/ 1" Stroke Tensioner	Ø 69.9mm	143.8mm	524.7mm
CC25 w/ 2" Stroke Tensioner	Ø 69.9mm	169.2mm	561.6mm

Dimensions in inches, in parentheses ( ) dimensions in millimeters

# CC Cylinder/Brake Combinations - CC30, CC40, CC52



## DIMENSIONS

### CYLINDER/ BRAKE COMBINATION FOR CC30, CC40, CC52

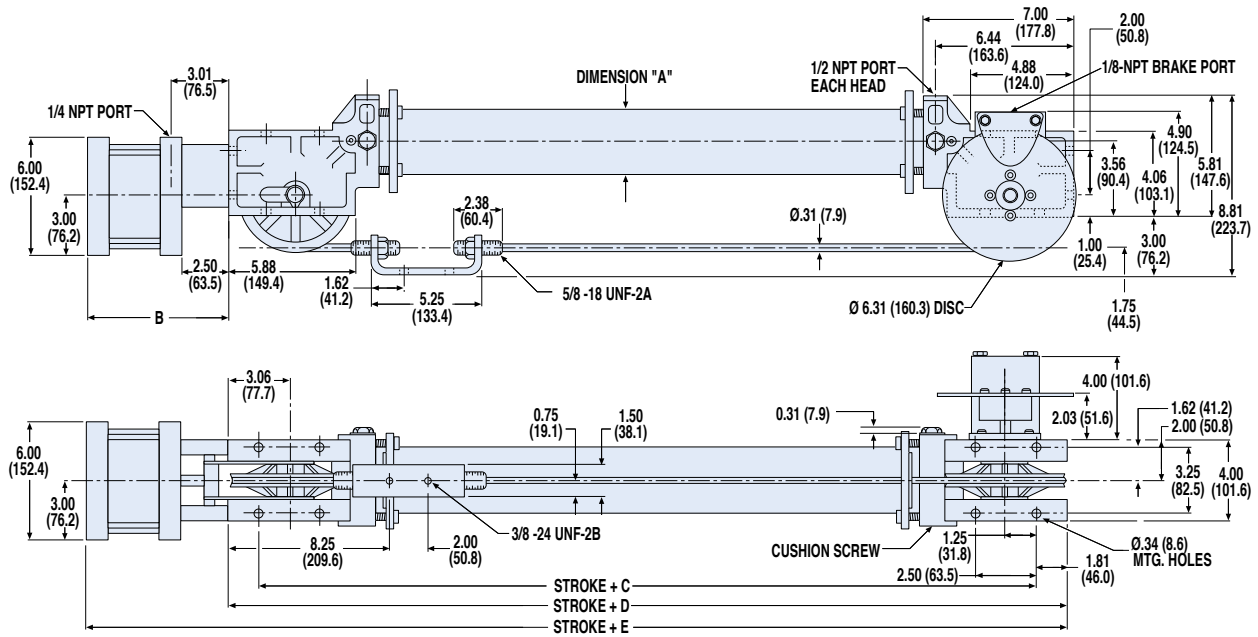

MODEL	A	B	C	D	E
CC30 w/ 1" Stroke Tensioner	Ø 3.25"	6.38"	13.87"	17.50"	23.89"
CC30 w/ 2" Stroke Tensioner	Ø 3.25"	7.38"	13.87"	17.50"	24.89"
CC40 w/ 1" Stroke Tensioner	Ø 4.25"	6.38"	14.87"	18.50"	24.89"
CC40 w/ 2" Stroke Tensioner	Ø 4.25"	7.38"	14.87"	18.50"	25.88"
CC52 w/ 1" Stroke Tensioner	Ø 2.25"	6.38"	13.87"	17.50"	23.89"
CC52 w/ 2" Stroke Tensioner	Ø 2.25"	7.38"	13.87"	17.50"	24.09"

MODEL	A	B	C	D	E
CC30 w/ 1" Stroke Tensioner	Ø 82.6mm	162.1mm	352.3mm	444.5mm	609.1mm
CC30 w/ 2" Stroke Tensioner	Ø 82.6mm	187.5mm	352.3mm	444.5mm	634.5mm
CC40 w/ 1" Stroke Tensioner	Ø 108.0mm	162.1mm	357.4mm	469.9mm	634.5mm
CC40 w/ 2" Stroke Tensioner	Ø 108.0mm	187.5mm	357.4mm	469.9mm	634.5mm
CC52 w/ 1" Stroke Tensioner	Ø 57.2mm	162.1mm	352.3mm	444.5mm	609.1mm
CC52 w/ 2" Stroke Tensioner	Ø 57.2mm	187.5mm	352.3mm	444.5mm	634.5mm

Dimensions in inches, in parentheses ( ) dimensions in millimeters

# CC, SA, DP, TC Switches - All Sizes

## SWITCHES

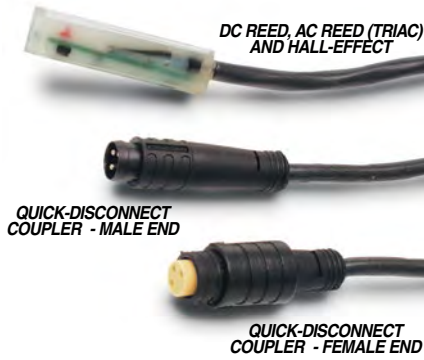

There are 10 sensing choices: DC reed, form A (open) or form C (open or closed); AC reed (Triac, open); Hall-effect, sourcing, PNP (open); Hall-effect, sinking, NPN (open); each with either flying leads or QD (quick disconnect). Commonly used to send analog signals to PLC (programmable logic controllers), TLL, CMOS circuit or other controller device. These switches are activated by the actuator's magnet.

Switches contain reverse polarity protection. QD cables are shielded; shield should be terminated at flying lead end.

If necessary to remove factory installed switches, be sure to reinstall on the same of side of actuator with scored face of switch toward internal magnet.

## SPECIFICATIONS

ORDER CODE	REED DC				REED AC	
	R T	R M	B T	B M	C T	C M
PART NUMBER	3600-9082	3600-9083	3600-9084	3600-9085	3600-9086	3600-9087
LEAD	5m	QD*	5m	QD*	5m	QD*
CABLE SHIELDING	Unshielded	Shielded†	Unshielded	Shielded†	Unshielded	Shielded†
SWITCHING LOGIC	"A" Normally Open		"C" Normally Open or Closed		Triac Normally Open	
MECHANICAL CONTACTS	Single-Pole Single-Throw		Single-Pole Double-Throw		Single-Pole Single-Throw	
COIL DIRECT	Yes		Yes		Yes	
POWER LED	None		None		None	
SIGNAL LED	Red 		None		None	
OPERATING VOLTAGE	200 Vdc max.		120 Vdc max.		120 Vac max.	
OUTPUT RATING	—		—		—	
OPERATING TIME	0.6 msec max. (including bounce)		0.7 msec max. (including bounce)		—	
OPERATING TEMPERATURE	-40°F [-40°C] to 158°F [70°C]					
RELEASE TIME	1.0 msec. max.		—		—	
ON TRIP POINT	—		—		—	
OFF TRIP POINT	—		—		—	
**POWER RATING (WATTS)	10.0 §		3.0 §§		10.0	
VOLTAGE DROP	2.6 V typical at 100 mA		NA		—	
RESISTANCE	0.1 Ω Initial (Max.)		—		—	
CURRENT CONSUMPTION	—		—		1 Amp at 86°F [30°C]	0.5 Amp at 140°F [60°C]
FREQUENCY	—		—		47 - 63 Hz	
CABLE MIN. BEND RADIUS	STATIC	0.630" [16mm]				
	DYNAMIC	Not Recommended				

**⚠ CAUTION: DO NOT OVER TIGHTEN SWITCH HARDWARE WHEN INSTALLING!**

**⚠ \*\* WARNING:** Do not exceed power rating (Watt = Voltage X Amperage). Permanent damage to sensor will occur.

\*QD = Quick Disconnect; Male coupler is located 6" [152mm] from sensor, Female coupler to flying lead (part #2503-1025) distance is 197" [5m] also see Cable Shielding specification above

**⚠ REPLACEMENT OF QD SWITCHES MANUFACTURED BEFORE JULY 1, 1997:** It will be necessary to replace or rewire the female end coupler.



**Reed Switch Life Expectancy:** Up to 200,000,000 cycles (depending on load current, duty cycle and environmental conditions)

†Shielded from the female quick disconnect coupler to the flying leads. Shield should be terminated at flying lead end.

§ Maximum current 500mA (not to exceed 10VA) Refer to Temperature vs. Current graph and Voltage Derating graph

§§ Maximum current 250mA (not to exceed 3VA) Refer to Temperature vs. Current graph and Voltage Derating graph

# CC, SA, DP, TC Switches - All Sizes

## PERFORMANCE

TEMP. vs CURRENT, DC REED

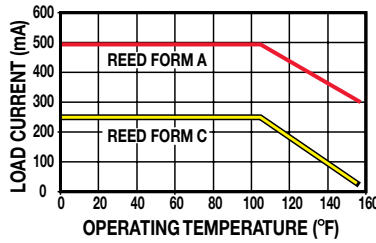

TEMP. vs CURRENT, AC REED

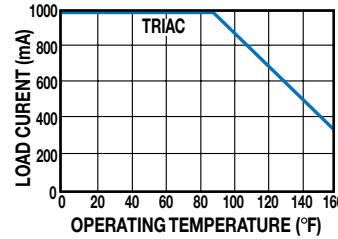

VOLTAGE DERATING, DC REED

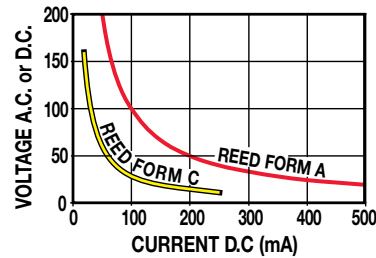

## WIRING DIAGRAMS

**R**T & **R**M DC REED, FORM A

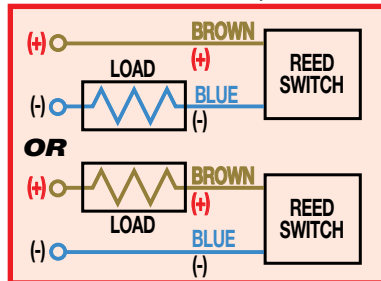

**C**T & **C**M AC REED, TRIAC

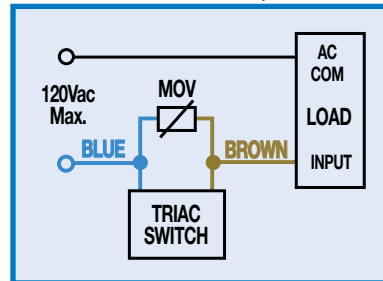

## INSTALLATION INFORMATION



**!** THE NOTCHED FACE OF THE SWITCH INDICATES THE SENSING SURFACE AND MUST FACE TOWARD THE MAGNET.

**B**T & **B**M DC REED, FORM C

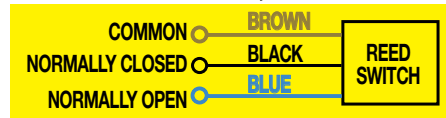

## DIMENSIONS

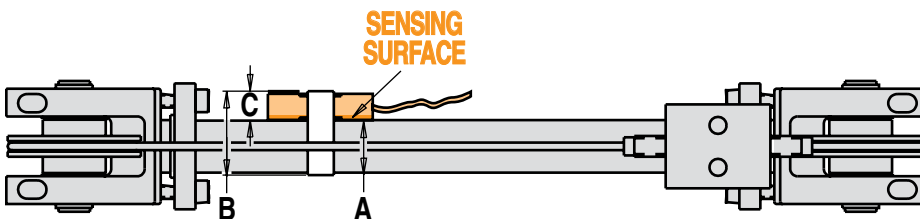
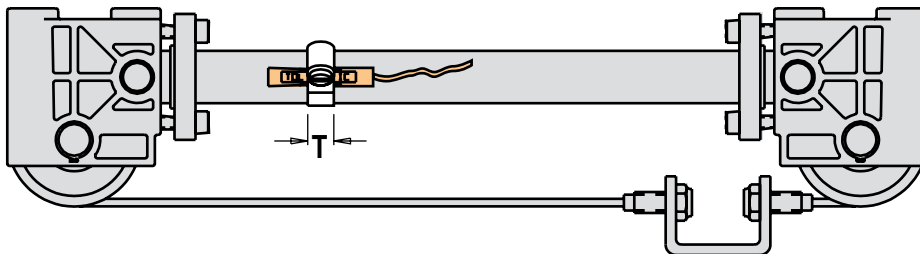

MODEL	BORE	A*	B	C	T
CCM05	0.50	0.81	1.09	0.35	0.31
CCM07	0.75	0.81	1.09	0.35	0.31
CCM10	1.00	1.12	1.65	0.35	0.31
CCM15	1.50	1.56	2.15	0.35	0.31
CCM20	2.00	2.08	2.65	0.35	0.31
CCM52	2.00	2.08	2.65	0.35	0.31
CCM25	2.50	2.75	3.15	0.35	0.31
CCM30	3.00	3.25	3.65	0.35	0.31
CCM40	4.00	4.25	4.65	0.35	0.56
CCM50	5.00	5.25	5.65	0.35	0.56

Above dimensions in inches  
\*Inside Dimension ±.06"

MODEL	BORE	A*	B	C	T
CCM05	0.50"	20.57	27.69	8.76	7.87
CCM07	0.75"	20.57	27.69	8.76	7.87
CCM10	1.00"	28.45	41.91	8.76	7.87
CCM15	1.50"	39.62	54.61	8.76	7.87
CCM20	2.00"	52.83	67.31	8.76	7.87
CCM52	2.00"	52.83	67.31	8.76	7.87
CCM25	2.50"	69.85	80.01	8.76	7.87
CCM30	3.00"	82.55	92.71	8.76	7.87
CCM40	4.00"	107.95	118.11	8.76	14.22
CCM50	5.00"	133.35	143.51	8.76	14.22

Above dimensions in millimeters  
\*Inside Dimension ±1.5mm

NOTE: HALL-EFFECT SWITCHES ARE NOT AVAILABLE FOR CABLE CYLINDERS  
SWITCHES ARE NOT AVAILABLE FOR CABLE CYLINDERS WITH STEEL TUBE  
DEAD LENGTH WILL INCREASE ON MOST MODELS, SEE BELOW

	MODEL	CCM05	CCM07 SAM07	CCM10 SAM10	CCM15 SAM15	CCM20 SAM20	CCM52 SAM52	CCM25 SAM25	CCM30 SAM30	CCM40 SAM40	CCM50
SPACE REQUIREMENTS - ADD DEAD LENGTH TO STROKE LENGTH	IN.	1.62	1.62	1.62	0.375	0.375	0.375	0.375	0.375	0.375	0
	MM	41.2	41.2	41.2	9.5	9.5	9.5	9.5	9.5	9.5	0



# CC: Cable Cylinder Selection Guidelines - All Sizes

## EXTERNAL LOAD GUIDANCE AND SUPPORT

The process of selecting a cable cylinder for a given application can be complex. It is highly recommended that you contact Tolomatic or a Tolomatic Distributor for assistance in selecting the best actuator for your application. The following overview of the selection guidelines are for educational purposes only.

### 1 COMPILE APPLICATION REQUIREMENTS

To determine the appropriate Cable Cylinder for an application, compile the following information:

- Available pressure (PSI)
- Weight of load (lbs. or kgs.)
- Orientation of load (lbs. or kgs.)
- Velocity of load (in./sec. or mm/sec.)
- Stroke length (in. or mm)

### 2 SELECT CYLINDER SIZE

- Consult the Theoretical Force vs. Pressure charts.
- Cross-reference the load force (or load weight if force is not known) and the available operating pressure. If the intersection falls below the diagonal line, and if moments do not exceed maximum values listed for that model (see Step 3), the actuator will accommodate the application. If the intersection is above the diagonal line, a larger cylinder bore size should be considered.

NOTE: Additional force may be required to obtain the necessary acceleration for vertical or horizontal loads.

### 3 DETERMINE INTERNAL CUSHION CAPACITY

- Consult the Cushion Data chart for the model selected. The velocities listed on the cushion charts are final or cushion impact velocities. On applications where the internal cushions or bumpers are to be used, be sure the actual, final or impact velocity is known. If the velocity is not known, use of limit switches with valve deceleration circuits or shock absorbers should be considered. Cross-reference the final velocity and weight of the load. If the intersection is below the diagonal lines, the internal cushions on the actuator may be used. If the point falls above the dashed diagonal line or if the velocity is not known, use deceleration circuits, external shock absorbers or select a larger cylinder with greater cushion capacity. On high-cyclic applications, use of external stops is strongly recommended.

NOTE: The 1/2-inch and 5-inch cable cylinders and all sizes of magnetically coupled cylinders do not have internal cushions.

The 1/2-inch cable cylinder can handle only very light inertial loads (5 pounds or less). Heavier loads require external stops or shock absorbers.

### 4 DETERMINE THE MAXIMUM STROKE LENGTHS FOR

### FULL MANUAL CABLE ADJUSTMENT (CC ONLY)

Once you have selected the proper bore size for your application and determined the cylinder's cushion capacity, you need to determine the physical stroke length limitation of the cylinder. Refer to the table below to find the bore size selected and its maximum stroke length.

NOTE: Maximum recommended stroke length for full manual cable adjustment is the maximum stroke length at which the cables can be properly proof-loaded, pretensioned and maintained at the required tension by manually adjusting the clevis terminal lock nuts. Maximum stroke length is based on the cylinder's maximum pressure rating.

If the stroke length for your application falls within the maximum stroke length for full manual cable adjustment, your model selection is complete. (Refer to graph on page cc\_31.)

IMPORTANT NOTE: Once a cylinder is installed in an application, but before putting it into service, the cables must be proof-loaded and pretensioned for proper operation. Refer to Application Guidelines on page cc\_36 for proof-loading and pretensioning methods.

If your stroke length is beyond the maximum stroke lengths shown, you have two options available.

1. Increase the maximum stroke length of the selected cylinder size by the percentage of the pressure differential between the cylinder's actual operating pressure and the cylinder's maximum rated operating pressure.

Example: If the cylinder selected is a CC15 (1½ - inch bore):

Actual PSI: 80

Max. PSI: 100

Differential: 20%

20% x 126 in. (maximum stroke) = 25.2 in.

25.2 + 126 = 151.2 in. (12.6 feet)

2. If your required stroke length is still more than the increased stroke length determined from option "1.", an automatic tensioner (AT) or multiple tensioners may be required.

For maximum stroke lengths when using auto tensioners, refer to the chart on page cc\_22.

NOTE: When using auto tensioners, the cylinder's cables must be proof-loaded and pretensioned before pressure is applied to the AT unit. Refer to Application Guidelines on page cc\_36 for proper proof-loading and pretensioning methods.

Auto tensioners are strongly recommended for vertical lifting applications and severe, high-cyclic applications even when the cylinder's stroke is within the maximum stroke length at full manual cable adjustment.

### 5 CONSIDER OPTIONS

Available options for cable cylinders include:

- Auto Tensioner
- Caliper Disc Brake
- Switches (DC Reed & Triac)
- Steel Tube (*Switches NOT available*)
- Seals of Viton® Material
- 3 Ported Heads

# CC: Cable Cylinder Selection Example

The procedure for selection of cable cylinder and magnetically coupled cylinder are very similar. For illustrative purposes, charts for the CC10 model are used in this example.

## 1 COMPILE APPLICATION REQUIREMENTS

- Available pressure **80 psi**
- Weight of load **30 lbs.**
- Orientation of load **horiz.**
- Final velocity\* of load **10" per sec**
- Stroke length **68"**

\*2x average velocity, see page CC\_38

## 2 SELECT CYLINDER SIZE

- Consult the Theoretical Force vs. Pressure charts.
- Cross-reference the load force and the available operating pressure. In this example a CC07 would accommodate this load at

### THEORETICAL FORCE vs PRESSURE

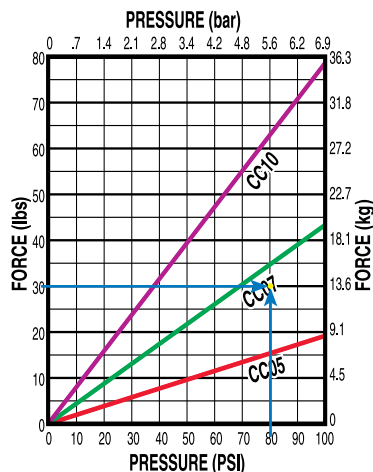

## 3 DETERMINE INTERNAL CUSHION CAPACITY

- Consult the Cushion Data Chart for the model selected.

In this example the calculated value for the final velocity and the load intersect at the line for the internal cushions capacity. Thus the CC10 will work for this application.

### CUSHION DATA

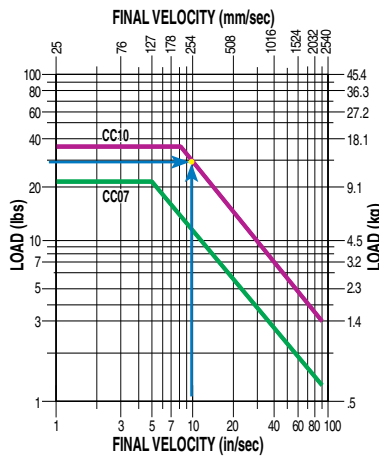

## 4 DETERMINE THE MAXIMUM STROKE LENGTHS FOR FULL MANUAL CABLE ADJUSTMENT (CC ONLY)

- Consult the chart at right.

In our example we are using 80 PSI, the chart indicates a maximum of 100 PSI, so we can calculate the maximum stroke length with manual adjustment:

$$1.20 \times 20.4" = 24.48"$$

Our stroke length is 68" so it will require the automatic tensioner option.

## 5 CONSIDER OPTIONS

This application will use Form C dc Reed switches to signal other units in this automated system.

The final configured string will appear as follows:

**CCM10SK68.000HIBM2**

### CC MAXIMUM STROKE LENGTHS

For Full Manual Cable Adjustment

	BORE		MAX PRESSURE		MAX STROKE	
	in	PSI	bar	in	mm	
CC05	0.50	100	6.89	20.40	518.2	
CC07	0.75	100	6.89	20.40	518.2	
CC10	1.00	100	6.89	20.40	518.2	
CC15	1.50	100	6.89	126.00	3200.4	
CC20	2.00	200	13.79	159.60	4053.8	
CC25	2.50	200	13.79	100.80	2560.3	
CC30	3.00	200	13.79	151.20	3840.5	
CC40	4.00	200	13.79	84.00	2133.6	
CC50	5.00	100	6.89	222.00	5638.8	
CC52	2.00	500	34.47	134.40	3413.8	

# CC: Caliper Disc Brake for Cable Cylinder Selection Guidelines

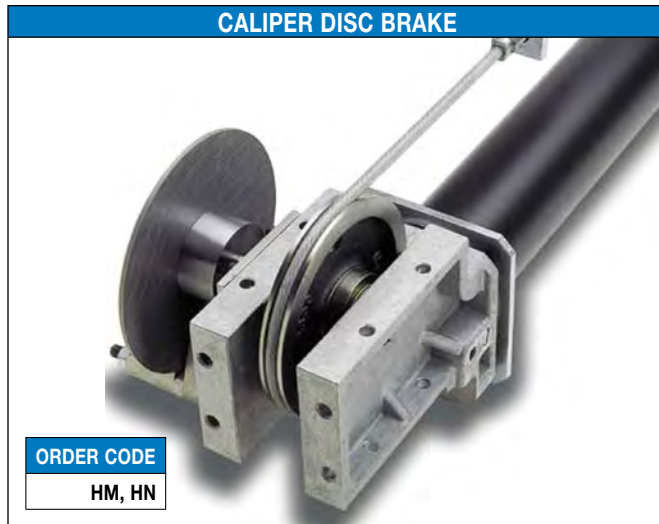

CALIPER DISC BRAKE

ORDER CODE

HM, HN

## DETERMINE THE LOAD CONFIGURATION AND THE HOLDING CAPACITY OF THE BRAKE

The following steps will help determine the adequate stopping time and distance for the cable cylinder equipped with a caliper disc brake under various conditions and loads.

1. *Select the bore size of the cable cylinder based on load to be moved.*  
Determine load pressure. Set regulator at 25% above load pressure ( $P_c$ ).

2. *Calculate the unbalanced cylinder force ( $F_c$ ) only if pressure is applied when braking.* If pressure is removed prior to braking, go on to 3.

$$F_c = P_c \times A_c$$

3. *Calculate the tangential braking force required.* This is ( $F_{tr}$ ) when pressure is removed prior to braking, or ( $F_{ta}$ ) when pressure is still applied when braking. Refer to illustrations in Figure 1.

Carefully note conditions:

$$F_{tr} = W \left[ \left( \frac{a}{g} - \sin \theta \right) - (f \cos \theta) \right], \text{ Horizontal or Load rising}$$

$$F_{tr} = W \left[ \left( \frac{a}{g} + \sin \theta \right) - (f \cos \theta) \right], \text{ Load falling}$$

$$F_{ta} = F_c + W \left( \frac{a}{g} - f \right), \text{ Horizontal loads}$$

$$= F_c + W \left[ \left( \frac{a}{g} - \sin \theta \right) - (f \cos \theta) \right], \text{ Incline load rising}$$

$$= F_c + W \left( \frac{a}{g} - 1 \right), \text{ Vertical load rising}$$

In the above expressions (a) can be calculated from:

$$a = \frac{V^2}{2S} \text{ or } \frac{V}{T}, \text{ In./Sec.}^2$$

4. *Calculate the tension required in brake side cable at the time of braking.*

$$L_{tr} = \frac{F_{tr}}{0.369}, \text{ lbs.; Pressure removed while braking}$$

$$L_{ta} = \frac{F_{ta}}{0.369}, \text{ lbs.; Pressure applied while braking}$$

### NOMENCLATURE

a = Deceleration, in/sec <sup>2</sup>	V = Velocity of load, in/sec.
g = Deceleration due to gravity = 386.4 in/sec <sup>2</sup>	W = Weight of load, lbs.
f* = Coefficient of friction of sliding load	W <sub>e</sub> = Equivalent Load, lbs.
f <sub>c</sub> = Coefficient of friction between cable and sheave	W <sub>e</sub> = W (Sin θ + f cos θ)
F <sub>c</sub> = Unbalanced cylinder force, lbs.	θ = Angle of inclination
F <sub>ta</sub> = Tangential braking force required with pressure still applied when braking, lbs.	(θ = 0° for horizontal)
F <sub>tr</sub> = Tangential braking force required with pressure removed prior to braking, lbs.	(θ = 90° for vertical)
L <sub>tr</sub> = Tension in cable of brake side half while braking with pressure removed, lbs.	R <sub>s</sub> = Root radius of sheave groove, inches
L <sub>ta</sub> = Tension in cable of brake side half while braking with pressure applied, lbs.	P <sub>c</sub> = Load Pressure, PSI
L <sub>t<sub>tm</sub></sub> = Maximum tension in cable with pressure removed while braking, lbs.	A <sub>c</sub> = Area of cable cylinder bore, in <sup>2</sup>
L <sub>t<sub>am</sub></sub> = Maximum tension in cable with pressure applied while braking, lbs.	P <sub>t</sub> = Load Pressure, PSI
S = Stopping distance, inches	A <sub>t</sub> = Area of tensioner cylinder, in <sup>2</sup>
T = Stopping time, seconds	P <sub>ba</sub> = Brake pressure setting. Pressure applied while braking, PSI
	P <sub>br</sub> = Brake pressure setting. Pressure removed while braking, PSI

\*Customer must precisely determine coefficient of friction (f), if this value is used.

# CC: Caliper Disc Brake for Cable Cylinder Selection Guidelines

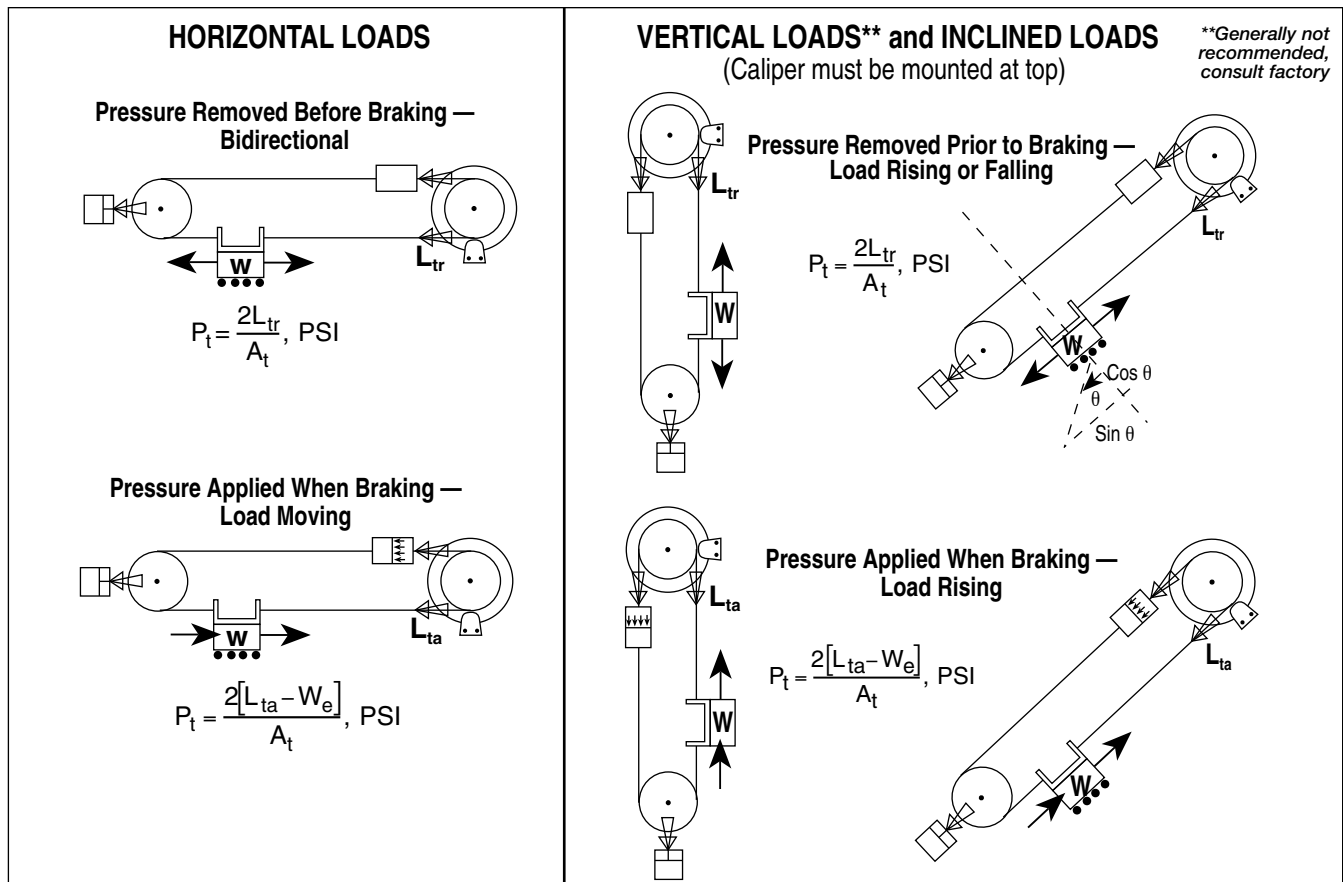

Figure 1

5. Calculate tensioner pressure setting, ( $P_t$ ) based on type of load configuration. See Figure 1 and Table 1

6. Calculate maximum tension in the cable with **pressure removed** prior to braking ( $L_{trm}$ ) or with **pressure applied** when braking ( $L_{tam}$ ).

Horizontal Loads:

$L_{trm} = L_{tr} + W_e$ , lbs.; Pressure removed prior to braking bidirectional

$L_{tam} = L_{ta}$ , lbs.; Pressure applied when braking and load moving toward caliper

$L_{tam} = L_{ta} + 2W_e$ , lbs.; Pressure applied when braking and load moving away from caliper.

Vertical or Inclined Loads:

$L_{trm} = L_{tr} + W_e$ , lbs.; Pressure removed prior to braking and load rising or falling

$L_{tam} = L_{ta}$ , lbs.; Pressure still applied when braking and load rising

7. Carefully check that ( $L_{trm}$ ) or ( $L_{tam}$ ) does not exceed 60% of the cable tensile strength\*. If they exceed the 60% figure, either stopping time or stopping distance has to be increased. Repeat steps 1 - 7.

8. Calculate the brake operating pressure. See Table 1

$P_{br} = .113 [L_{tr} R_s]$ , PSI; Pressure removed prior to braking

$P_{ba} = .113 [L_{ta} R_s]$ , PSI; Pressure still applied when braking

9. If pressure is removed prior to braking, check to see if brake can hold the load if application is either vertical or inclined.

The brake can hold the load if:

$$.369 L_{tr} \geq W_e$$

\*Refer to Cable Specifications in the double-acting cable cylinder section of this catalog for cable tensile strengths.

Table 1

	$A_t$ ; in <sup>2</sup>	$R_s$ ; in.	$A_c$ ; in <sup>2</sup>
CC07	2.30		
CC10	2.30		
CC15	2.30	1.531	1.767
CC20	11.96	2.00	3.142
CC25	11.96	2.00	4.909
CC30	16.20	2.50	7.069
CC40	16.20	2.50	12.566
CC52	16.20	2.50	3.142
CC50	27.05		



# Application Data Worksheet

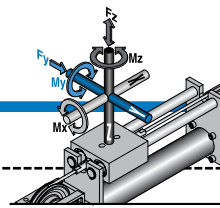

**STROKE LENGTH** \_\_\_\_\_

inch (S)  (K)  millimeters  
(U.S. Standard) (Metric)

**AVAILABLE AIR PRESSURE** \_\_\_\_\_

PSI  bar  
(U.S. Standard) (Metric)

**REQUIRED THRUST FORCE** \_\_\_\_\_

lbf  N  
(U.S. Standard) (Metric)

**LOAD** \_\_\_\_\_

lb  kg  
(U.S. Standard) (Metric)

**LOAD CENTER OF GRAVITY DISTANCE TO CARRIER CENTER**

inch  millimeters  
(U.S. Standard) (Metric)

$d_x$  \_\_\_\_\_

$d_y$  \_\_\_\_\_

$d_z$  \_\_\_\_\_

**ORIENTATION**

Horizontal

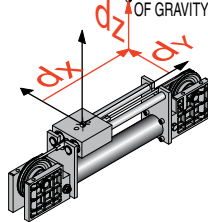

Side

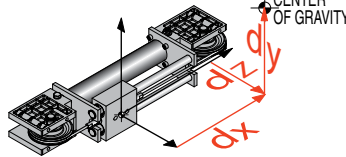

Horizontal Down

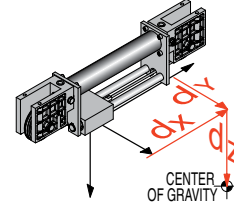

Vertical

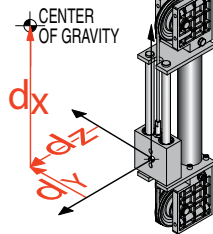

Angled  $\alpha$  \_\_\_\_\_

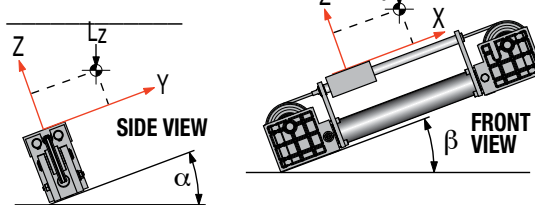

**FORCES APPLIED TO CARRIER**  $F_z$  \_\_\_\_\_  
 $F_y$  \_\_\_\_\_

lbf  N  
(U.S. Standard) (Metric)

**BENDING MOMENTS APPLIED TO CARRIER**  $M_x$  \_\_\_\_\_  
 $M_y$  \_\_\_\_\_  
 $M_z$  \_\_\_\_\_

in-lbs  N-m  
(U.S. Standard) (Metric)

**FINAL VELOCITY** \_\_\_\_\_

in/sec  mm/sec  
(U.S. Standard) (Metric)

**MOVE TIME** sec. \_\_\_\_\_

**NO. OF CYCLES** \_\_\_\_\_

per minute  per hour

**OTHER ISSUES:** (i.e. \_\_\_\_\_  
Environment, \_\_\_\_\_  
Temperature, \_\_\_\_\_  
Contamination, etc.) \_\_\_\_\_

**Contact information:** \_\_\_\_\_  
\_\_\_\_\_  
\_\_\_\_\_  
\_\_\_\_\_

Fax (1-763-478-8080) or call Tolomatic (1-800-328-2174) with the above information. We will provide any assistance needed to determine the proper actuator.

# TC: Track Cable Cylinder Selection Guidelines - All Sizes

## PROVIDING LOAD GUIDANCE AND SUPPORT

### 1 COMPILE APPLICATION REQUIREMENTS

To determine the appropriate Track Cable Cylinder for an application, compile the following information:

- Available pressure (PSI)
- Weight of load (lbs. or kgs.)
- Orientation of load (lbs. or kgs.)
- Velocity of load (in./sec. or mm/sec.)
- Stroke length (in. or mm)

### 2 SELECT CYLINDER SIZE

- Consult the Theoretical Force vs. Pressure charts.
- Cross-reference the load force (or load weight if force is not known) and the available operating pressure. If the intersection falls below the diagonal line, and if moments do not exceed maximum values listed for that model (see Step 3), the actuator will accommodate the application. If the intersection is above the

diagonal line, a larger cylinder bore size should be considered.

NOTE: Additional force may be required to obtain the necessary acceleration for vertical or horizontal loads.

### 3 KEEP UNDER MAXIMUM STROKE LENGTH

There are specific maximum stroke lengths for each model.  
 TC05: 67.00"  
 TC07: 78.00"  
 TC10: 78.00"  
 TC15: 282.59"

### 4 DETERMINE NATURE OF LOAD AND THE EFFECT OF BENDING MOMENTS

If the actuator will guide and support a load located directly over the center of carrier, bending moments will not be a factor in the actuator selection. Track Cable Cylinders perform best that way. See the Bending Moments Formulae below if your application requires the load to be away from center of the carrier.

### 5 DETERMINE THE BEARING ROD LOAD CAPACITY

Determine whether the Load Weight and Stroke Length will be within the load capacity for the bearing rods.

Cross reference the load weight and stroke on the Load Weight vs. Stroke chart for the selected bore size. (Page cc\_20, cc\_21) If the intersection falls within the curve, the cylinder will accommodate the application requirements. If the intersection falls outside the curve, consult the chart of a larger bore size that will accommodate the required load weight and stroke for your application.

The weight on the bearing rods causes them to bend or deflect slightly over their length. This deflection is increased for longer rods and/or higher weights on the bearing block. For proper operation, rod deflection must not exceed .30 of an inch.

### 6 DETERMINE INTERNAL CUSHION CAPACITY

- Consult the Cushion Data chart (Cushion Data for Track Cable Cylinders page cc\_7 to cc\_11) for the model selected. The velocities listed on the cushion charts are final or cushion impact velocities. On applications where internal cushions are to be used, be sure the actual, final or impact velocity is known. If the velocity is not known, use of limit switches with valve deceleration circuits or shock absorbers should be considered.

## BENDING MOMENTS

### Loading Equation Data

MODEL	BORE SIZE	A (in.)	D (in.)	F (lbs.)	G (lbs.)
TC05	1/2"	1.09	1.0	14.00	-
TC07	3/4"	1.09	1.0	14.00	-
TC10	1"	1.09	1.0	14.00	-
TC15	1-1/2"	1.68	2.31	90.00	-

### Loading Equation Key

- A = Distance between shaft centers.
- B = Distance from load center to center of nearest shaft (in.); determined by application.

- L = Load per shaft (lbs.).
- W = Payload weight (lbs.).
- D = Axial distance between center of bearings (in.).

- F = Max. bearing sliding load (linear bearings) (lbs.)
- G = Max. bearing sliding load (sintered bronze bearings) (lbs.)

#### "L" MOMENT

$$L = \frac{W}{2}$$

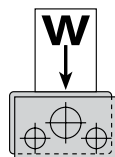

#### "Mx" MOMENT

$$L = \frac{WB}{A}$$

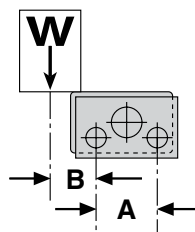

#### "My" / "Mz" MOMENT

$$F \text{ or } G = 2L = \frac{WB}{D}$$

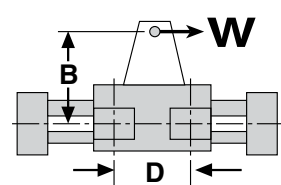

# CC Cable Cylinder Application Guidelines - All Sizes

## 1 PROOF-LOADING AND PRETENSIONING CABLES

Once installed, but before putting in service, the cables on the cylinder should be proof-loaded and pretensioned to ensure that they are rigid for the maximum service life of the cylinder.

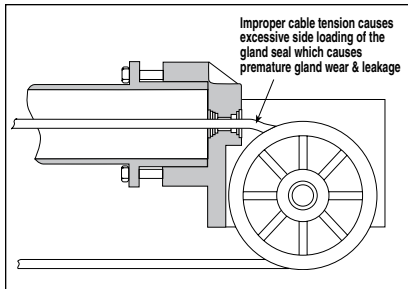

Proof-loading and pretensioning involve removing the two types of stretch in the cable by adjusting the clevis terminal lock nuts.

- *Proof-loading* – When cables are manufactured, individual wires and strands are laid in position but left slightly loose. When subjected to proof-loading the wires align themselves, tighten and constructional stretch in the cable is eliminated.
- *Pretensioning* – Elastic stretch in cable is inherent in the wire itself. It is removed when subjected to pretensioning.

There are two ways to proof-load and pretension a cylinder's cables — The Torque Method or The Field Method. These two methods are explained at right. Either method may be used.

All cables should be checked periodically from a preventative maintenance standpoint. When installing new cable assemblies proof-load and pretension using these same methods.

## THE TORQUE METHOD

1. Tighten the clevis terminal lock nuts equally with a torque wrench to the values listed under Proof-loading torque in the Proof-loading, Pretensioning table below.
2. Let tightened nuts sit for 30 seconds.
3. Loosen the lock nuts to remove tension (but tight enough to eliminate any slack).
4. Re-torque clevis terminal lock nuts equally with a torque wrench to the total pretensioning figures listed in the table below.

PROOF-LOADING AND PRETENSIONING TORQUE OF CABLES								
CC Model	Proof-loading Torque		Pretensioning Torque		Starting Torque of Nuts on Terminals		Total Pretensioning Torque	
CC05	15in.-lbs.	1.69N-m	2.5in.-lbs.	0.28 N-m	10in.-lbs.	1.13 N-m	12.5in.-lbs.	1.41 N-m
CC07	15in.-lbs.	1.69N-m	2.5in.-lbs.	0.28 N-m	10in.-lbs.	1.13 N-m	12.5in.-lbs.	1.41 N-m
CC10	15in.-lbs.	1.69N-m	2.5in.-lbs.	0.28 N-m	10in.-lbs.	1.13 N-m	12.5in.-lbs.	1.41 N-m
CC15	45in.-lbs.	5.08N-m	8.0in.-lbs.	0.90 N-m	20in.-lbs.	2.26 N-m	28.8in.-lbs.	3.25 N-m
CC20	115in.-lbs.	12.99N-m	46.0in.-lbs.	5.20 N-m	25in.-lbs.	2.82 N-m	71.0in.-lbs.	8.02 N-m
CC25	115in.-lbs.	12.99N-m	73.0in.-lbs.	8.25 N-m	25in.-lbs.	2.82 N-m	98.0in.-lbs.	11.07 N-m
CC30	210in.-lbs.	23.73N-m	105.0in.-lbs.	11.86 N-m	25in.-lbs.	2.82 N-m	130.0in.-lbs.	14.69 N-m
CC40	210in.-lbs.	23.73N-m	187.5in.-lbs.	21.19 N-m	25in.-lbs.	2.82 N-m	212.5in.-lbs.	24.01 N-m
CC50	325in.-lbs.	36.72N-m	180.0in.-lbs.	20.34 N-m	30in.-lbs.	3.39 N-m	210.0in.-lbs.	23.73 N-m
CC52	210in.-lbs.	23.73N-m	115.0in.-lbs.	12.99 N-m	25in.-lbs.	2.82 N-m	140.0in.-lbs.	15.82 N-m

## THE FIELD METHOD

The Field Method simplifies Proof-loading and Pretensioning the cable cylinder by combining the two processes.

1. Block the load some distance from the end of stroke to keep the piston from bottoming.
2. Apply a pressure that is 15% to 20% higher than the actual load pressure.

**NOTE:** Load pressure is defined as the pressure required to move the load. When the load is stopped externally, before the piston bottoms, the relief

valve or regulator setting becomes the load pressure.

3. Upon pressurizing, one cable will become tight while the other will become slack. Manually adjust out the slack with a wrench on the clevis terminal lock nut.
4. Release the pressure, block the load on the other side and repeat steps 1 through 3. When these steps are done, turn down the regulator pressure to the normal operating pressure and remove the block.

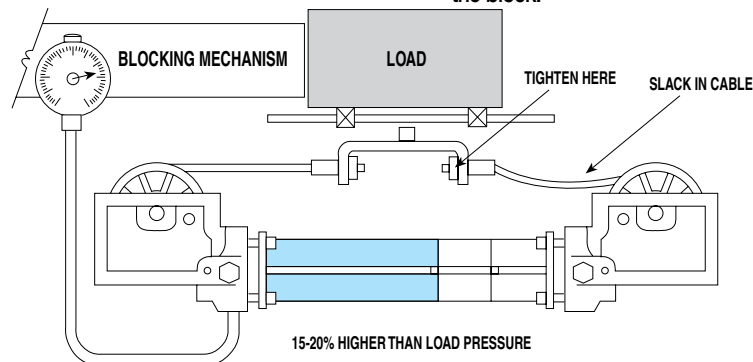

# CC Cable Cylinder Application Guidelines - All Sizes

## 2 DETERMINING SPECIAL CABLE LENGTHS

When an application requires a specialized cable length, use the dimensional table and illustrations to determine the proper cable length.

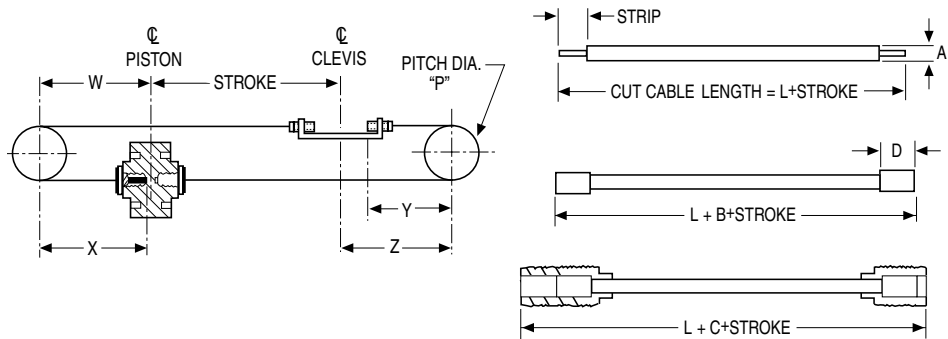

MODEL	P		W		X		Y		Z		STRIP		A		B		C		D		L(std) + Stroke	
	in.	mm.	in.	mm.	in.	mm.	in.	mm.	in.	mm.	in.	mm.	in.	mm.	in.	mm.	in.	mm.	in.	mm.	in.	mm.
CC05	1.500	38.1	1.687	42.8	1.350	34.3	1.406	35.7	1.687	42.8	0.328	8.3	0.093	2.4	0.234	5.9	0.375	9.5	0.437	11.1	4.68	118.9
CC07	1.500	38.1	1.687	42.8	1.350	34.3	1.406	35.7	1.687	42.8	0.328	8.3	0.093	2.4	0.234	5.9	0.375	9.5	0.437	11.1	4.68	118.9
CC10	1.500	38.1	1.687	42.8	1.350	34.3	1.406	35.7	1.687	42.8	0.328	8.3	0.093	2.4	0.234	5.9	0.375	9.5	0.437	11.1	4.68	118.9
CC15	3.250	82.6	4.452	113.1	4.325	109.9	3.725	94.6	4.452	113.1	0.468	11.9	0.187	4.7	0.343	8.7	0.420	10.7	0.828	21.0	12.50	317.5
CC20	4.250	108.0	5.125	130.2	4.688	119.1	3.426	87.0	5.125	130.2	0.620	15.7	0.250	6.4	0.641	16.3	0.540	13.7	1.060	26.9	14.25	362.0
CC25	4.250	108.0	5.125	130.2	4.688	119.1	3.426	87.0	5.125	130.2	0.620	15.7	0.250	6.4	0.641	16.3	0.540	13.7	1.060	26.9	14.25	362.0
CC30	5.312	134.9	5.687	144.4	5.000	127.0	3.601	91.5	5.687	144.4	0.844	21.4	0.312	7.9	0.500	12.7	0.195	5.0	1.100	27.9	17.00	431.8
CC40	5.312	134.9	6.187	157.1	5.000	127.0	4.315	109.6	6.187	157.1	0.844	21.4	0.312	7.9	0.500	12.7	0.195	5.0	1.100	27.9	17.50	444.5
CC50	6.000	152.4	9.370	238.0	8.630	219.2	7.820	198.6	9.370	238.0	1.180	30.0	0.375	9.5	1.000	25.4	0.500	12.7	1.930	49.0	24.55	623.6
CC52	5.312	134.9	5.702	144.8	5.000	127.0	3.850	97.8	5.702	144.8	0.844	21.4	0.312	7.9	0.500	12.7	0.195	5.0	1.100	27.9	17.00	431.8

## 3 LUBRICATION GUIDELINES

All Tolomatic cable cylinders require internal lubrication unless specified. To ensure maximum cylinder life, the following guidelines should be followed.

### • Filtration

We recommend the use of dry, filtered air in our products. "Filtered air" means a level of 10 Micron or less. "Dry" means air should be free of appreciable amounts of moisture. Regular maintenance of installed filters will generally keep excess moisture in check.

### • External Lubricators

External lubrication should be utilized for maximum service life of pneumatic cable cylinders.

Lubrication must be maintained in a constant supply or the results will be a dry cylinder prone to premature wear.

Oil lubricators, (mist or drop) should supply a minimum of 1 drop per 20 standard cubic feet per minute to the cylinder. As a rule of thumb, double that rate if water in the system is suspected. Demanding conditions may require more lubricant.

We recommend a **non-detergent, 20cP @ 140°F** 10-weight lubricant. Optimum conditions for standard cylinder operation are **+32° to +125°F (+0° to 51.6°C)**.

### • Sanitary environments

Oil mist lubricators must dispense "Food Grade" lubricants to the air supply. Use fluids with ORAL **LD50 toxicity ratings of 35 or higher** such as **Multitherm® PG-1 or equivalent**. Demanding conditions can require a review of the application.

# Application Guidelines

The following conditional statements are intended as general guidelines for use of Tolomatic actuators. Since all applications have their own specific operating requirements, consult Tolomatic, Inc. or your local Tolomatic distributor if an application is unconventional or if questions arise regarding the selection process.

## CUSHION NEEDLE ADJUSTMENT (BC2, BC3, BC4, CC, SA, DP, TC ONLY)



Adjust the cushion needles in the cylinder heads carefully to obtain a smooth, hesitation free deceleration for your particular application. If there are questions on proper adjustment, please consult Tolomatic, Inc.

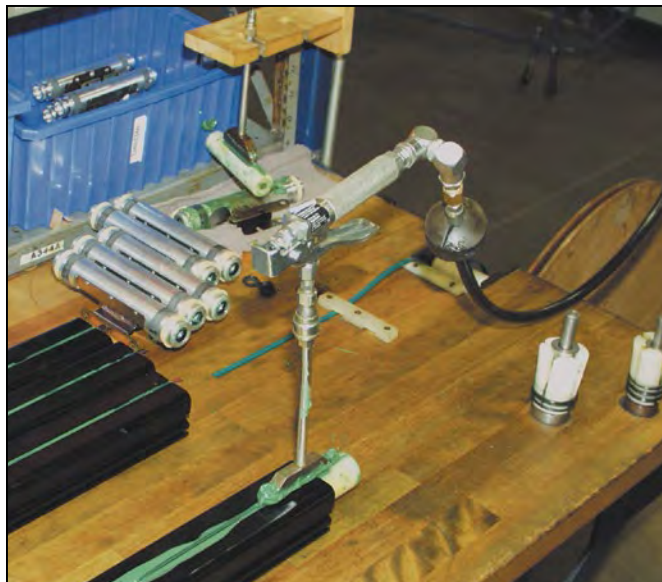

## LUBRICATION GUIDELINES

All Tolomatic actuators (except Cable Cylinders) are prelubricated at the factory. To ensure maximum actuator life, the following guidelines should be followed.

### • Filtration

We recommend the use of dry, filtered air in our products. "Filtered air" means a level of 10 Micron or less. "Dry" means air should be free of appreciable amounts of moisture. Regular maintenance of installed

filters will generally keep excess moisture in check.

### • External Lubricators (optional)

The factory prelubrication of Tolomatic actuators will provide optimal performance without the use of external lubrication. However, external lubricators can further extend service life of pneumatic actuators if the supply is kept constant.

Oil lubricators, (mist or drop) should supply a minimum of 1 drop per 20 standard cubic feet per minute to the

cylinder. As a rule of thumb, double that rate if water in the system is suspected. Demanding conditions may require more lubricant.

If lubricators are used, we recommend a non-detergent, 20cP @ 140°F 10-weight lubricant. Optimum conditions for standard cylinder operation are +32° to +150°F (+0° to 65.5°C).

NOTE: Use of external lubricators may wash away the factory installed lubrication. External lubricants must be maintained in a constant supply or the results will be a dry actuator prone to premature wear.

### • Sanitary Environments

Oil mist lubricators must dispense "Food Grade" lubricants to the air supply. Use fluids with ORAL LD50 toxicity ratings of 35 or higher such as Multitherm® PG-1 or equivalent. Demanding conditions can require a review of the application.

## FINAL VELOCITY CALCULATION

Velocity calculations for all rodless cylinders need to differentiate between final velocity and average velocity. For example: Stroking a 100-inch BC3 model in one second yields an average velocity of 100 inches per second. To properly determine the inertial forces for cushioning, it is important to know the

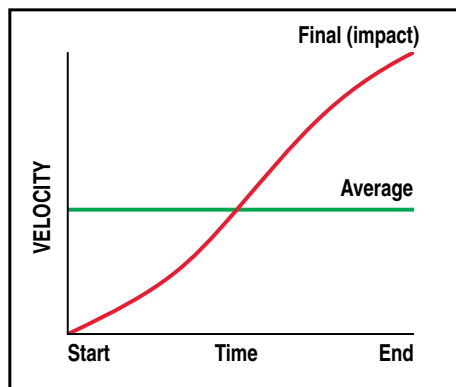

final (or impact) velocity. Rodless cylinders accelerate and decelerate at each end of the stroke. Therefore this acceleration must be considered (see diagram).

If final (or impact) velocity cannot be calculated directly, a reasonable guideline is to use 2 x average velocity.



# CC, SA, DP, TC Service Parts Ordering - ALL Sizes

## CABLE ASSEMBLIES<sup>1</sup> AND REPAIR KITS<sup>2</sup> PART NUMBERS

Find the appropriate part number for the specific model and specify that part number with your stroke length when ordering.

MODEL	CABLE ASSY.	REPAIR KITS
CC05	CACC05	RKCC05
TC05	CATC05	RKTC05
CCM05	CACCM05	RKCCM05
TCM05	CATCM05	RKTCM05
CC07	CACC07	RKCC07
SA07	CASA07	RKSA07
TC07	CATC07	RKTC07
CCM07	CACCM07	RKCCM07
SAM07	CASAM07	RKSAM07
TCM07	CATCM07	RKTCM07
CC10	CACC10	RKCC10
SA10	CASA10	RKSA10
TC10	CATC10	RKTC10
CCM10	CACCM10	RKCCM10
SAM10	CASAM10	RKSAM10
TCM10	CATCM15	RKTCM10
CC15	CACC15	RKCC15
DP15	CADP15	RKDP15
SA15	CASA15	RKSA15
TC15	CATC15	RKTC15
CCM15	CACCM15	RKCCM15
DPM15	CADPM15	RKDPM15
SAM15	CASAM15	RKSAM15
TCM15	CATCM15	RKTCM15
CC20	CACC20	RKCC20
DP20	CADP20	RKDP20
SA20	CASA20	RKSA20
CCM20	CACCM20	RKCCM20
DPM20	CADPM20	RKDPM20
SAM20	CASAM20	RKSAM20
CC25	CACC25	RKCC25
DP25	CADP25	RKDP25
SA25	CASA25	RKSA25
CCM25	CACCM25	RKCCM25
DPM25	CADPM25	RKDPM25
SAM25	CASAM52	RKSAM25
CC52	CACC52	RKCC52
DP52	CADP52	RKDP52
SA52	CASA52	RKSA52
CCM52	CACCM52	RKCCM52
DPM52	CADPM52	RKDPM52
SAM52	CASAM52	RKSAM52
CC30	CACC30	RKCC30
DP30	CADP30	RKDP30
SA30	CASA30	RKSA30
CCM30	CACCM30	RKCCM30
DPM30	CADPM30	RKDPM30
SAM30	CASAM30	RKSAM30
CC40	CACC40	RKCC40
DP40	CADP40	RKDP40
SA40	CASA40	RKSA40
CCM40	CACCM40	RKCCM40
DPM40	CADPM40	RKDPM40
SAM40	CASAM40	RKSAM40
CC50(ALL)	CACC50	RKCC50
SA50(ALL)	CASA50	RKSA50

## CONFIGURATED REPAIR KIT<sup>2</sup> ORDERING EXAMPLE:

OPTION	MODEL, BORE	STROKE
RK	CCVM 07	SK42.5

Where **RK** is the Repair Kit code, **CCVM** is the Cable Cylinder Code with seals of Viton<sup>®</sup> material, 07 is the .75" bore and **SK 42.5** indicates a stroke length of 42.5 inches.



### Service Parts Ordering NOTES:

- 1 Cable Assemblies contain: one Cable Assembly (specify stroke).
- 2 Repair Kits contain: two Cable Assemblies (specify stroke) and all wearable seals required to rebuild the cylinder.

## SWITCH ORDERING

PART NUMBER ORDERING		CONFIG. CODE ORDERING
No Mounting Hardware or FE conn. included		Mounting Hardware & FE conn. included
PART NO.	DESCRIPTION	CODE
3600-9084	Switch Only, Reed, Form C, 5m	BT
3600-9085	Switch Only, Reed, Form C, Male Conn.	BM
3600-9082	Switch Only, Reed, Form A, 5m	RT
3600-9083	Switch Only, Reed, Form A, Male Conn.	RM
3600-9086	Switch Only, Triac, 5m	CT
3600-9087	Switch Only, Triac, Male Conn.	CM
2503-1025	Connector (Female) 5 meter lead	

NOTE: When ordered by Config. Code Female connector & all mounting hardware is included



### Switch Ordering NOTES:

To order field retrofit switch and hardware kits for all Tolomatic actuators: SW (Then the model and bore size, and type of switch required)

#### Example: SWCCM15RT

(Hardware and Form A Reed switch with 5 meter lead for 1.5" bore cable cylinder)

# Cable Cylinder Ordering - CC, SA, DP, TC - All Sizes

MODEL, BORE, STROKE										OPTIONS																
<b>CC</b>	<b>V</b>	<b>M</b>	<b>15</b>	<b>S</b>	<b>K</b>	<b>1</b>	<b>2</b>	<b>5</b>	<b>0</b>	<b>END #1</b>	<b>H</b>	<b>J</b>	<b>END #2</b>	<b>H</b>	<b>G</b>	<b>R</b>	<b>T</b>	<b>2</b>	<b>X</b>	<b>A</b>	<b>0</b>	<b>0</b>	<b>X</b>	<b>B</b>	<b>0</b>	<b>0</b>

### MODEL

**CC** Double Acting Cable Cylinder  
**SA** Single Acting Cable Cylinder  
**DP** Double Purchase Cable Cylinder  
**TC** Track Cable Cylinder

### SEALS

**V** Seals of Viton® material

### TUBING

**S** Steel Tube  
✗ Not available for 05, 07 or 50 size  
✗ Switches cannot be used with steel tubing

### SWITCH MAGNET

**M** Internally Mounted Magnet  
 Required for use with switches  
 Magnet will increase dead length of CC, SA & DP actuator (see page CC\_29)

### BORE SIZE

<b>05</b> 0.50" (16mm)	<b>25</b> 2.50" (63mm)
<b>07</b> 0.75" (19mm)	<b>30</b> 3.00" (76mm)
<b>10</b> 1.00" (25mm)	<b>40</b> 4.00" (100mm)
<b>12</b> 1.25" (32mm)	<b>50</b> 5.00" (127mm)
<b>15</b> 1.50" (40mm)	<b>52</b> 2.00" [500 PSI]
<b>20</b> 2.00" (50mm)	(50mm)

### STROKE LENGTH

**SK** \_\_\_ Enter desired stroke length in decimal inches

NOTE: Strokes over 281" (7137mm) require Tube Couplers. Consult Tolomatic for lead time. Max. stroke length varies by model and bore size, see dimensions page for specification.

### HEAD OPTIONS (CC\_22 & CC\_25)

Single-ported heads are standard on all cylinders.  
 Enter head options for [END #1, right end] and/or [END #2, left end] of the cylinder

- 1,3HG** 3-ported head
  - HI** 1" auto tensioner assembly
  - 3HJ** 1" auto tensioner assembly with 3-ported head
  - HK** 2" auto tensioner assembly
  - 3HL** 2" auto tensioner assembly with 3-ported head
  - 2HM** caliper disc brake assembly
  - 2,3HN** caliper disc brake assembly with 3-ported head

<sup>1</sup>Only head option available for single-acting cylinders  
<sup>2</sup>Autotensioner assembly required on one end of the cylinder  
<sup>3</sup>Cushions are removed on all 3-ported heads

### SWITCHES (CC\_28)

	TYPE	QUICK-DISCONNECT	CODE	QUANTITY	LEAD LENGTH
REED	Form A	QD	<b>RM</b>	After code enter quantity desired	5 meters
		no	<b>RT</b>		
	Form C	QD	<b>BM</b>		
		no	<b>BT</b>		
TRIAC	QD	<b>CM</b>			
	no	<b>CT</b>			

### EXTRA CABLE

**XA** for extra beyond standard in inches  
**XB** for extra beyond standard in inches

**Not all codes listed are compatible with all options. Contact Tolomatic with any questions.**