

# Technical data

A broad selection of new Value Line suction cups in flat, bellows and long bellows designs.



## Value Line cups

- ▶ Suction cup program suitable for standard applications, such as carton and cardboard erecting (low to medium speed), metal/wood sheet loading and unloading, parts removal from injection molding machines and clamping/holding.
- ▶ Durable material with good wear resistance.
- ▶ Thin sealing lip gives good grip even on slightly textured and corrugated surfaces.
- ▶ Available with metal fitting or push-on directly to a pipe.
- ▶ Every cup size has a few fitting options.

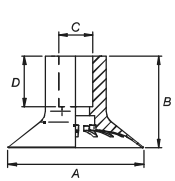
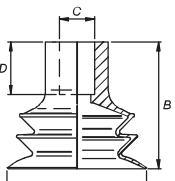
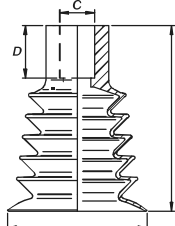
Type	Name	Lifting forces vertical to the surface, N, at vacuum level 50 -kPa	Dim. A mm	Dim. B mm	Dim. C mm	Dim. D mm	Art. no.
Flat Concave 	VL20FC	10	Ø20	15	Ø6	9	0202096
	VL25FC	17	Ø25	15.8	Ø6	9	0202097
	VL30FC	23	Ø30	17.5	Ø6	9	0202099
	VL40FC	38	Ø40	27	Ø10	15	0202100
	VL50FC	58	Ø50	29	Ø10	15	0202101
	VL60FC	79	Ø60	35.5	Ø12	18	0202102
	VL75FC	113	Ø75	38.3	Ø12	18	0202103
Bellows 	VL20BX	7	Ø20	19.5	Ø6	9	0202109
	VL25BX	12	Ø25	22.3	Ø6	9	0202110
	VL30BX	16	Ø30	25.6	Ø6	9	0202111
	VL40BX	29	Ø40	36.3	Ø10	15	0202113
	VL50BX	44	Ø50	43.6	Ø10	15	0202114
	VL60BX	60	Ø58	52.2	Ø12	18	0202115
	VL75BX	89	Ø71.7	61.2	Ø12	18	0202116
Long Bellows 	VL20BL	6	Ø20	27.9	Ø6	9	0202117
	VL25BL	11	Ø25	33.5	Ø6	9	0202118
	VL30BL	15	Ø30	37.1	Ø6	9	0202119
	VL40BL	23	Ø40	53.1	Ø10	15	0202120
	VL50BL	35	Ø50	62.5	Ø10	15	0202121
	VL60BL	48	Ø60	76.3	Ø12	18	0202122
	VL75BL	76	Ø75	92.7	Ø12	18	0202123

Fittings (brass)							Fitting for cup				
							VL20FC VL25FC VL30FC VL20BX VL25BX VL30BX VL20BL VL25BL VL30BL			VL40FC VL50FC VL40BX VL50BX VL40BL VL50BL	VL60FC VL75FC VL60BX VL75BX VL60BL VL75BL
Size and threads	Size mm	Dim. E mm	Dim. F mm	Dim. G mm	SW	Art. no.					
G1/8" - M5 Diameter 6	Ø6	11	23	3	3	0202156	●				
G1/4" - G1/8" Diameter 6	Ø6	14	26	3	3	0202157	●				
G1/4" - G1/8" Diameter 10	Ø10	15	35	4	6	0202158		●			
G1/4" - G1/8" Diameter 12	Ø12	15	40	4	6	0202159			●		
G3/8" - G1/4" Diameter 10	Ø10	15	35	4	6	0202164		●			
G3/8" - G1/4" Diameter 12	Ø12	15	40	4	6	0202165			●		
NPT 1/8" - M5	Ø6	10	22	n/a	3	0202160	●				
NPT 1/4" - NPSF 1/8"	Ø6	15	27	n/a	3	0202161	●				
NPT 1/4" - NPSF 1/8"	Ø10	15	35	n/a	6	0202162		●			
NPT 1/4" - NPSF 1/8"	Ø12	15	39	n/a	6	0202163			●		
NPT 3/8" - NPSF 1/4"	Ø10	15	35	n/a	6	0202166		●			
NPT 3/8" - NPSF 1/4"	Ø12	15	39	n/a	6	0202167			●		

## Build height, B+E

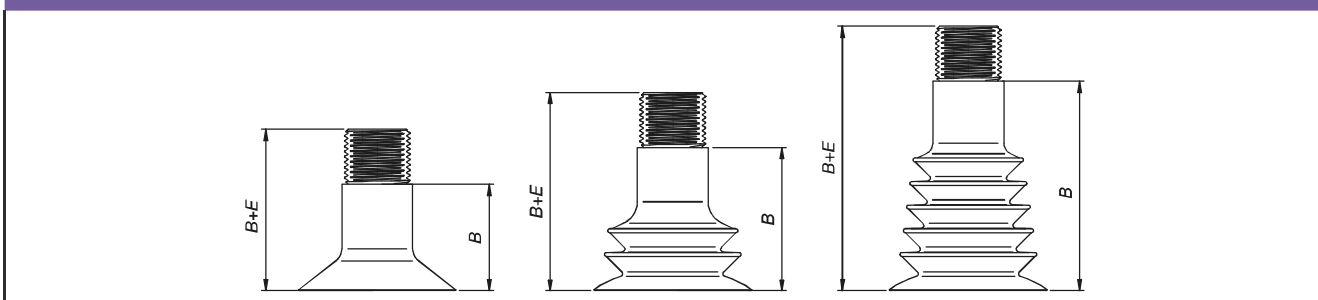

## Material specification

Material	TPE-U
Color	Purple
Temperature	0 - 60/80* °C

\* Max Temperature short term contact, <10 sec and 50% intermittence, ambient temperature 15 - 30 °C, mechanical properties will start to degrade.

**Value Line**

Good performance at a value price