

B3S & B3W ELECTRIC RODLESS ACTUATORS

 **ENDURANCE TECHNOLOGY**™

**B3S SCREW-DRIVE
B3W BELT-DRIVE**



LINEAR SOLUTIONS MADE EASY



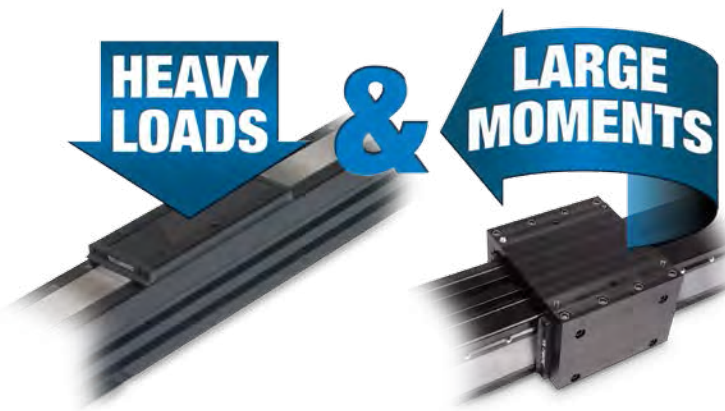

Tolomatic B3S & B3W Electric Rodless Actuators



The Power to Move Heavy Loads





The B3S and B3W electric rodless actuators have very large moment and load carrying capacities. The sealed recirculating ball bearing design makes it an excellent choice for challenging environments. For even higher capacity (loads up to 8,000 lbs.) choose the Dual 180° Carrier and add an auxiliary carrier. Both actuators utilize a patented internal re-circulating ball bearing guidance system that provides extremely long life. These actuators are capable of carrying loads up to 8,000 lbs.

A COMPARISON OF SCREW DRIVE ACTUATORS

	B3S	MXE-S	MXE-P	TKS
Features:				
	High load and bending moment capacities	Basic guidance and support	High load and bending moment capacities	Superior rigidity, high moment load capacities
Load up to: (with options)	8,000 lbf [35,586 N]	1,040 lbf [4,626 N]	2,584 lbf [11,494 N]	1,500 lbf [6,672 N]
Thrust up to:	2,700 lbf [12,010 N]	4,300 lbf [19,127 N]	4,300 lbf [19,127 N]	3,260 lbf [14,501 N]
Speed up to:	60 in/sec [1,524 mm/sec]	60 in/sec [1,524 mm/sec]	60 in/sec [1,524 mm/sec]	60 in/sec [1,524 mm/sec]
Stroke Length up to:	179 in [4,547mm]	178 in [4,521 mm]	178 in [4,521 mm]	96 in [2,438 mm]
Screw/Nut Type	Solid & Ball	Solid & Ball	Solid & Ball	Solid & Ball
<i>www.tolomatic.com for complete information, search by literature number:</i>				
Literature Number:	3600-4176	8300-4000	8300-4000	3600-4609

(Not all models deliver ALL maximum values listed, i.e.: Maximum thrust may not be available with maximum speed)

A COMPARISON OF BELT DRIVE ACTUATORS

	B3W	MXB-U	MXB-P	TKB
Features:				
	High load and bending moment capacities	Basic thrust, requires external guidance and support	High load and bending moment capacities	Superior rigidity, high moment load capacities
Load up to: (with options)	8,000 lbf [35,586 N]	NA	2,584 lbf [11,494 N]	1,500 lbf [6,672 N]
Thrust up to:	325 lbf [1,446 N]	418 lbf [1,859 N]	418 lbf [1,859 N]	245 lbf [1,090 N]
Speed up to:	200 in/sec [5,080 mm/sec]	200 in/sec [5,080 mm/sec]	150 in/sec [3,810mm/sec]	100 in/sec [2,540 mm/sec]
Stroke Length up to:	207 in [5,258 mm]	230 in [5,842 mm]	230 in [5,842 mm]	96 in [2,438 mm]
<i>www.tolomatic.com for complete information, search by literature number:</i>				
Literature Number:	3600-4176	8500-4000	8500-4000	3600-4609

(Not all models deliver ALL maximum values listed, i.e.: Maximum thrust may not be available with maximum speed)

B3S & B3W Applications

Applying, Dispensing

- Spraying
- Cutting
- Slitting
- Test Fixtures
- Inspection

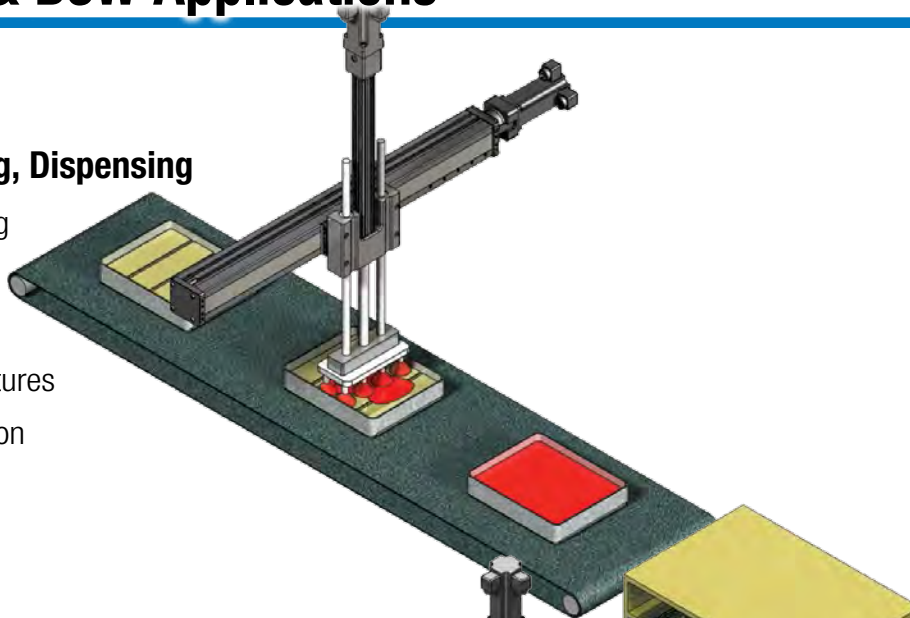

Storage & Retrieval

- Parts Transfer
- Pick & Place
- Stacking
- Sorting

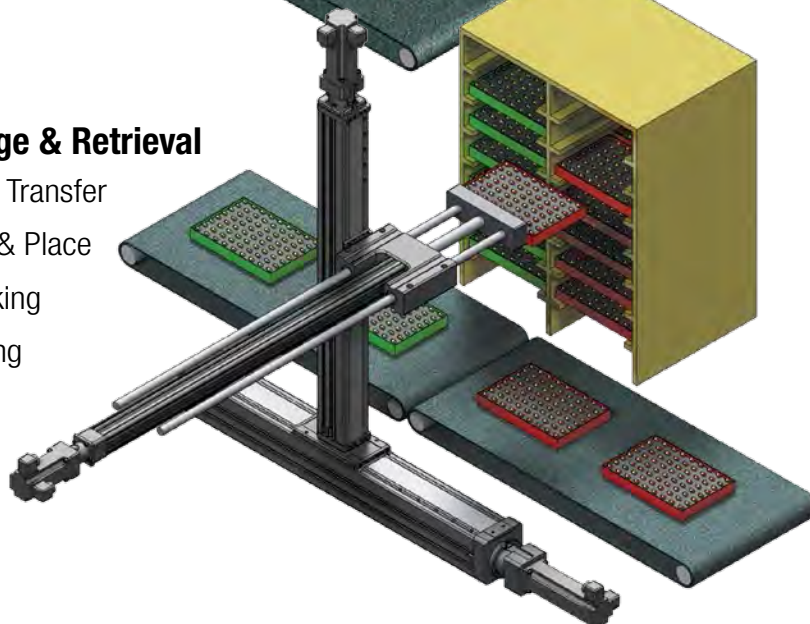

X-Y Gantry/Multi Axis

- Laser marking
- Material cutting
- Adhesive dispensing

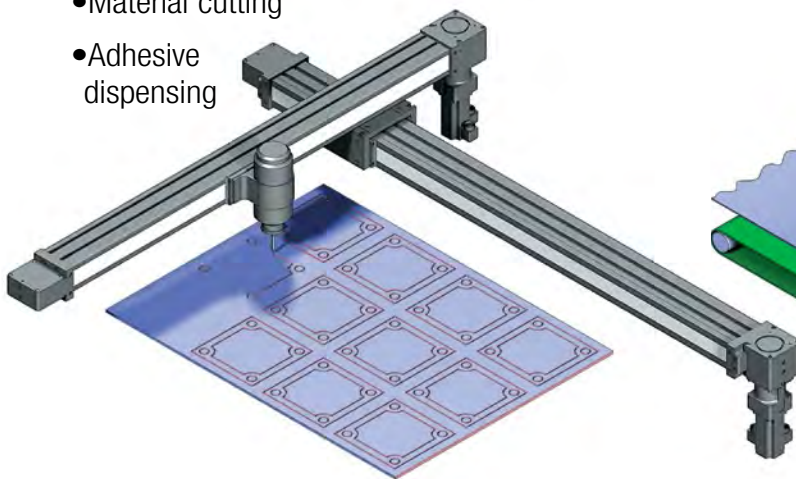

High Speed Flying Cut Off

- Test stations
- Product handling
- Camera positioning

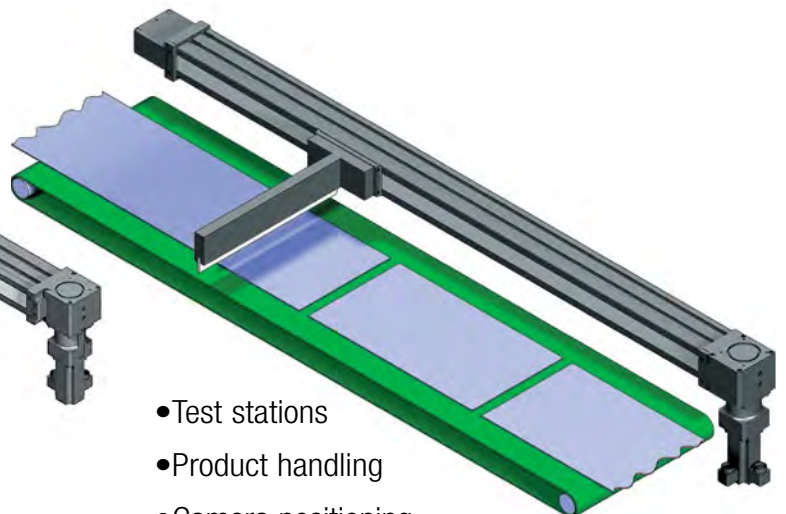

CONTENTS

Rodless Comparisons.....	B3_2
B3S & B3W Applications.....	B3_3
B3S Features.....	B3_4
B3W Features.....	B3_6
B3S & B3W Performance....	B3_8
B3S Specifications.....	B3_9
Critical Speed (Acme).....	B3_13
PV Limits (Acme).....	B3_14
Critical Speed (Ball).....	B3_15
Ball Screw Life.....	B3_16
B3S Dimensions.....	B3_17-24
B3W Performance.....	B3_25
B3W Specifications.....	B3_26
B3W Dimensions.....	B3_28-34
Switches.....	B3_34
Application Data Worksheet.....	B3_36
Selection Guidelines.....	B3_37
B3s Ordering.....	B3_39
B3W Ordering.....	B3_39
Other Tolomatic Products.....	B3_40

B3S RODLESS SCREW DRIVE ACTUATOR

ENDURANCE TECHNOLOGYSM

Endurance Technology features are designed for maximum durability to provide extended service life.

The B3S rodless screw-drive electric actuator is designed for carrying moderate to heavy loads with large bending moment capacity. The B3S utilizes a patented integral recirculating ball bearing guidance system that provides durable performance and extremely long life. Choose from multiple screw technologies for thrust up to 2,700 lbf. Built-to-order in stroke lengths up to 179 inches.

LOAD-BEARING CARRIER DESIGN

- Recirculating ball bearing system provides guidance, high efficiency and durability
- Load and moments are transmitted directly to the actuator body

FORMED END CAP WIPERS

- Prevent contaminants from entering the sealing band area to protect internal components

B3S

B3W

INTERNAL BUMPERS

- Bumpers protect the screw and nut assembly from damage at end of stroke

STAINLESS STEEL SEALING BAND

- Prevents contaminants from entering the screw and nut area for extended performance
- Fatigue resistant stainless steel bands are specifically made to offer long life and will not elongate
- Provides IP44 protection for bearings and screw nut

MULTIPLE SCREW TECHNOLOGIES

YOU CAN CHOOSE:

- Solid nuts of bronze or engineered resins offer quiet performance at the lowest cost; anti-backlash available
- Ball nuts offer positioning accuracy and repeatability with longer life; low-backlash available



SCREW SUPPORT BEARINGS

- Unique high thrust bearing assembly design eliminates runout and isolates the linear forces from the drive shaft

LIGHTWEIGHT ALUMINUM DESIGN

- Black anodized extrusion design is optimized for rigidity and strength
- External switch channels on both sides allow easy placement and adjustment of position indicating switches

PATENTED WEDGE BEARING SYSTEM



- Unique design incorporates hardened steel raceways integral to the aluminum extrusion
- Bearing surfaces are adjusted at the factory for optimum preload and smooth performance

MOTOR ORIENTATION
YOU CAN CHOOSE:

- Inline option directly couples the driving shaft and is typically a one-piece housing construction for optimum alignment and support of the motor
- Reverse-parallel option minimizes the overall length and offers a belt reduction drive with a 1:1 or 2:1 ratio

YOUR MOTOR HERE
YOU CAN CHOOSE:

- Specify the device to be installed and actuator ships with proper mounting hardware
- Specify and ship your device to Tolomatic for factory installation
- Motor or gearbox supplied and installed by Tolomatic

OPTIONS

CARRIER OPTIONS

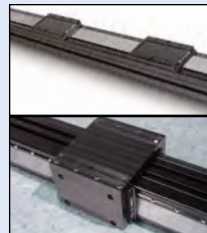

- **AUXILIARY CARRIER** doubles the load capacity and increases pitch and yaw bending moment capacities
- **DUAL 180° CARRIER** doubles the load capacity, increases roll and yaw bending moment capacities and offers a wide mounting platform

MOUNTING OPTIONS



- **SURFACE MOUNT** two t-slots are integral on the entire underside of the actuator body for direct mounting
- **TUBE SUPPORTS** provide intermediate support of the actuator body throughout long stroke lengths
- **MOUNTING PLATES** provide intermediate support of the actuator body throughout long stroke lengths

METRIC OPTION

Provides metric tapped holes for mounting of load to carrier and of actuator to mating surfaces

SWITCHES



Styles include: reed, hall-effect or triac. Select either 15ft potted cable with flying leads or 6in to quick-disconnect coupler with mating 15ft cable

B3S

B3W

B3W RODLESS BELT-DRIVE ACTUATOR

ENDURANCE TECHNOLOGYSM

Endurance Technology features are designed for maximum durability to provide extended service life.

The B3W rodless belt-drive electric actuator is designed for carrying moderate to heavy loads at moderate to high speeds with large bending moment capacity. The B3W utilizes a patented integral recirculating ball bearing guidance system that provides durable performance and extremely long life. The B3W belt-driven actuator features speeds up to 200 in/sec. Built-to-order in stroke lengths up to 207 inches.

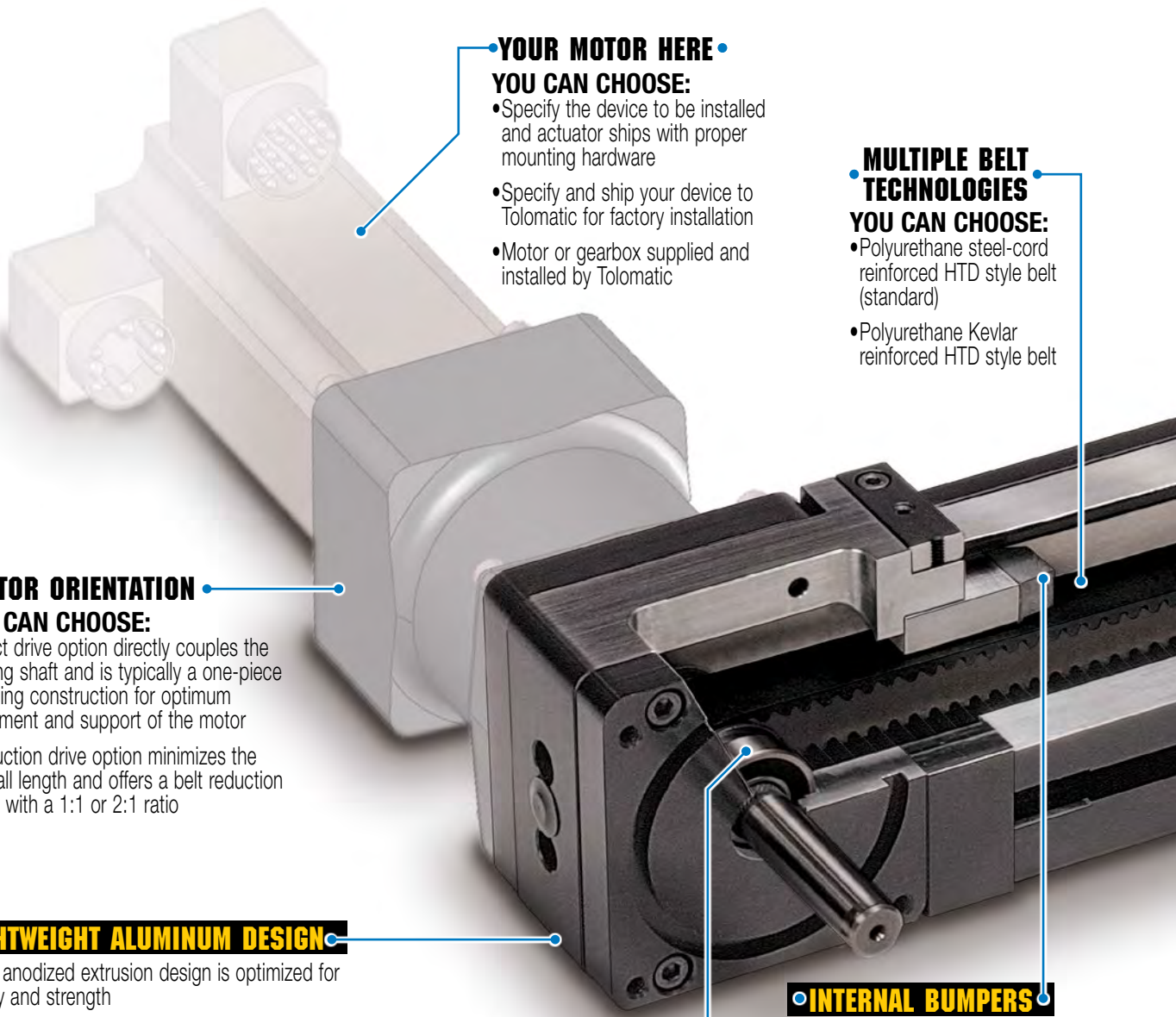

YOUR MOTOR HERE

YOU CAN CHOOSE:

- Specify the device to be installed and actuator ships with proper mounting hardware
- Specify and ship your device to Tolomatic for factory installation
- Motor or gearbox supplied and installed by Tolomatic

MULTIPLE BELT TECHNOLOGIES

YOU CAN CHOOSE:

- Polyurethane steel-cord reinforced HTD style belt (standard)
- Polyurethane Kevlar reinforced HTD style belt

MOTOR ORIENTATION

YOU CAN CHOOSE:

- Direct drive option directly couples the driving shaft and is typically a one-piece housing construction for optimum alignment and support of the motor
- Reduction drive option minimizes the overall length and offers a belt reduction drive with a 1:1 or 2:1 ratio

LIGHTWEIGHT ALUMINUM DESIGN

- Black anodized extrusion design is optimized for rigidity and strength
- External switch channels on both sides allow easy placement and adjustment of position indicating switches

OVERSIZED PULLEY BEARINGS

- Drive shaft assembly incorporates sealed ball bearings for complete support of the increased belt tension at high speeds

INTERNAL BUMPERS

- Bumpers protect the belt and clamp assembly from damage at end of stroke

B3S

B3W

PATENTED WEDGE BEARING SYSTEM



- Unique design incorporates hardened steel raceways integral to the aluminum extrusion
- Bearing surfaces are adjusted at the factory for optimum preload and smooth performance

FORMED END CAP WIPERS

- Prevent contaminants from entering the sealing band area to protect internal components

BELT TENSIONING SYSTEM

- Full access to the idle pulley allows ease of adjustment for alignment and tensioning
- Dual adjustment screws and field tensioning kit provide simple maintenance



LOAD-BEARING CARRIER DESIGN

- Recirculating ball bearing system provides guidance, high efficiency and long life
- Load and moments are transmitted directly to the actuator body

STAINLESS STEEL SEALING BAND

- Prevents contaminants from entering the belt and pulley area for extended performance
- Fatigue resistant stainless steel bands are specifically made to offer long life and will not elongate
- Provides IP44 protection for bearings and interior components

OPTIONS



CARRIER OPTIONS

- **AUXILIARY CARRIER** doubles the load capacity and increases pitch and yaw bending moment capacities
- **DUAL 180° CARRIER** doubles the load capacity, increases roll and yaw bending moment capacities and offers a wide mounting platform



MOUNTING OPTIONS

- **SURFACE MOUNT** two t-slots are integral on the entire underside of the actuator body for direct mounting
- **TUBE SUPPORTS** provide intermediate support of the actuator body throughout long stroke lengths
- **MOUNTING PLATES** provide intermediate support of the actuator body throughout long stroke lengths
- **METRIC OPTION**
Provides metric tapped holes for mounting of load to carrier and of actuator to mating surfaces



SWITCHES

- Styles include: reed, hall-effect or triac. Select either 15ft potted cable with flying leads or 6in to quick-disconnect coupler with mating 15ft cable



B3S

B3W

B3S & B3W Electric Rodless Actuators

SPECIFICATIONS both Screw & Belt Drive

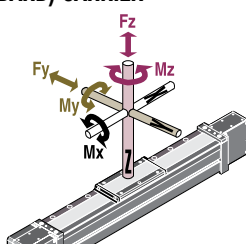
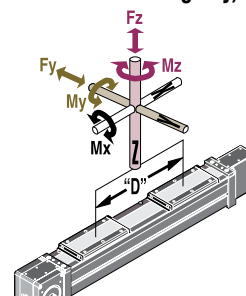
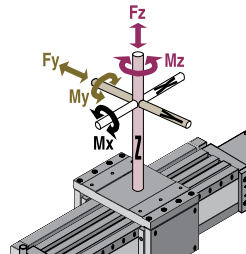
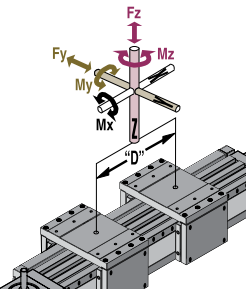

DYNAMIC BENDING MOMENTS AND LOADS

	Size	U.S. CONVENTIONAL			METRIC		
		10	15	20	10	15	20
SINGLE (STANDARD) CARRIER							
	Mx Moment (Roll) (lb-in : N-m)	250	859	1,662	28.2	97	188
	My Moment (Pitch) (lb-in : N-m)	269	1,033	1,472	30.4	117	166
	Mz Moment (Yaw) (lb-in : N-m)	156	596	850	17.6	67	96
	Fy Load (Radial) (lb : N)	341	840	1,159	1,517	3,737	5,155
	Fz Load (Lateral) (lb : N)	591	1,454	2,008	2,629	6,468	8,932
AUXILIARY CARRIER: Increases rigidity, load-carrying capacity and moments							
	Mx Moment (Roll) *(lb-in : N-m)	500	1,718	3,324	57	194	376
	My Moment (Pitch) *(lb-in : N-m)	2,825	11,734	16,265	319	1,326	1,838
	Mz Moment (Yaw) *(lb-in : N-m)	1,630	6,779	9,388	184	766	1,061
	Fy Load (Radial) (lb : N)	682	1,680	2,318	3,034	7,473	10,311
	Fz Load (Lateral) (lb : N)	1,182	2,908	4,016	5,258	12,935	17,864
	Minimum Dimension 'D' (in : mm)	4.88	8.07	8.10	124	205	206
DUAL 180° CARRIER: Allows 90° rotation of load, adds load bearing surface							
	Mx Moment (Roll) (lb-in : N-m)	657	2,468	4,527	74	279	512
	My Moment (Pitch) (lb-in : N-m)	312	1,192	1,700	35.3	135	192
	Mz Moment (Yaw) (lb-in : N-m)	538	2,066	2,944	61	233	333
	Fy Load (Radial) (lb : N)	1,182	2,908	4,016	5,258	12,935	17,864
	Fz Load (Lateral) (lb : N)	682	1,680	2,318	3,034	7,473	10,311
AUXILIARY DUAL 180° CARRIER: Substantially increases moment and loads							
	Mx Moment (Roll) *(lb-in : N-m)	1,314	4,936	9,054	149	558	1,023
	My Moment (Pitch) *(lb-in : N-m)	3,328	13,558	18,776	376	1,532	2,121
	Mz Moment (Yaw) *(lb-in : N-m)	5,768	23,468	32,530	652	2,652	3,675
	Fy Load (Radial) (lb : N)	2,364	5,816	8,032	10,516	25,871	35,728
	Fz Load (Lateral) (lb : N)	1,364	3,360	4,636	6,067	14,946	20,622
	Minimum Dimension 'D' (in : mm)	4.88	8.07	8.10	124	205	206

⚠ The Dual 180° carrier requires its own proprietary tube supports and foot mounts. See dimensional information. Breakaway torque will also increase when using the Auxiliary carrier or the Dual 180° carrier options. When ordering, determine working stroke and enter this value into the configuration string. Overall actuator length will automatically be calculated.

Deflection Considerations: In applications where substantial Mx or My moments come into play, deflection of the cylinder tube, carrier and supports must be considered. The deflection factors shown in the Load Deflection charts on the following page are based on cylinder mounted with tube supports at minimum recommended spacing. If more rigidity is desired, refer to the Auxiliary or Dual Carrier options.

*Loads shown in table are at minimum "D" dimension, for ratings with longer "D" dimension see graphs on page B3_10.

Life of the actuator will vary for each application depending on the combined loads, motion parameters and operating conditions. The load factor (L_F) ratios for each application must not exceed a value of 1.5 (see formula at right). Exceeding a load factor of 1.5 will diminish the actuator's rated life.

$$L_F = \frac{M_x}{M_{x_{max}}} + \frac{M_y}{M_{y_{max}}} + \frac{M_z}{M_{z_{max}}} + \frac{F_y}{F_{y_{max}}} + \frac{F_z}{F_{z_{max}}} \leq 1.5$$

With combined loads, L_F must not exceed the value 1.5

B3S & B3W Electric Rodless Actuators

SPECIFICATIONS both Screw & Belt Drive



LOAD DEFLECTION

DEFLECTION ABOUT X AXIS

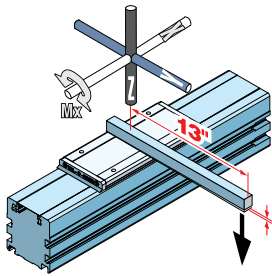

DEFLECTION TESTING WAS DONE UNDER THESE CRITERIA:

- 1.) Actuator was properly mounted with distance between supports within recommendations (see Support Recommendations below)
- 2.) Deflection was measured from center of carrier as shown ($M_x = 13"$, $M_y = 8"$)

DEFLECTION ABOUT Y AXIS

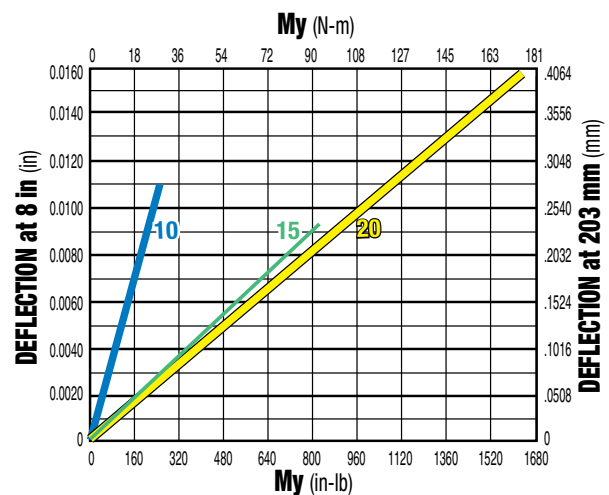
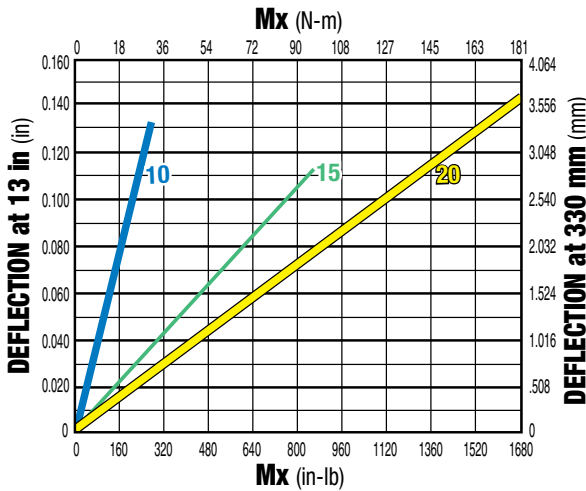
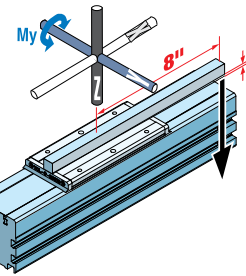

SUPPORT RECOMMENDATIONS

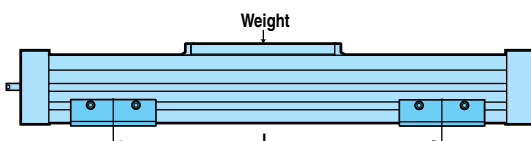
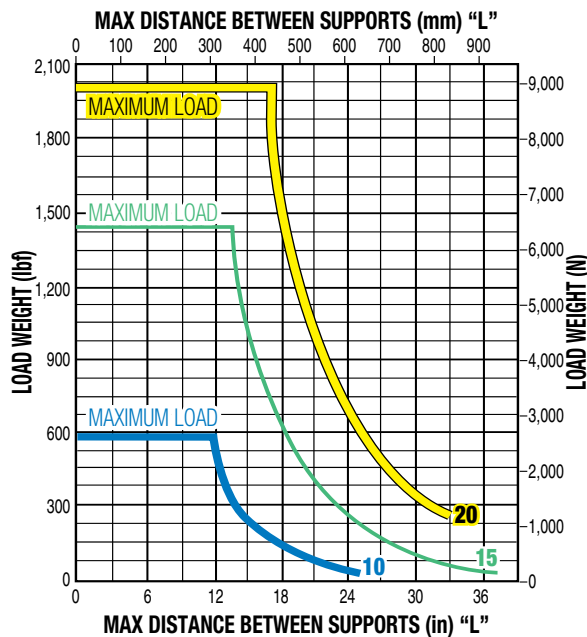

FRICITION FORCE

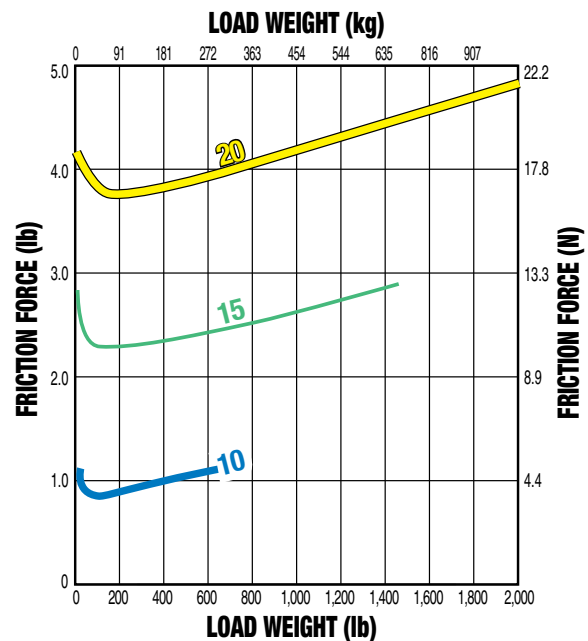

B3S

B3W

B3S & B3W Electric Rodless Actuators

SPECIFICATIONS both Screw & Belt Drive



AUXILIARY CARRIER: BENDING MOMENT AT 'D' DISTANCE

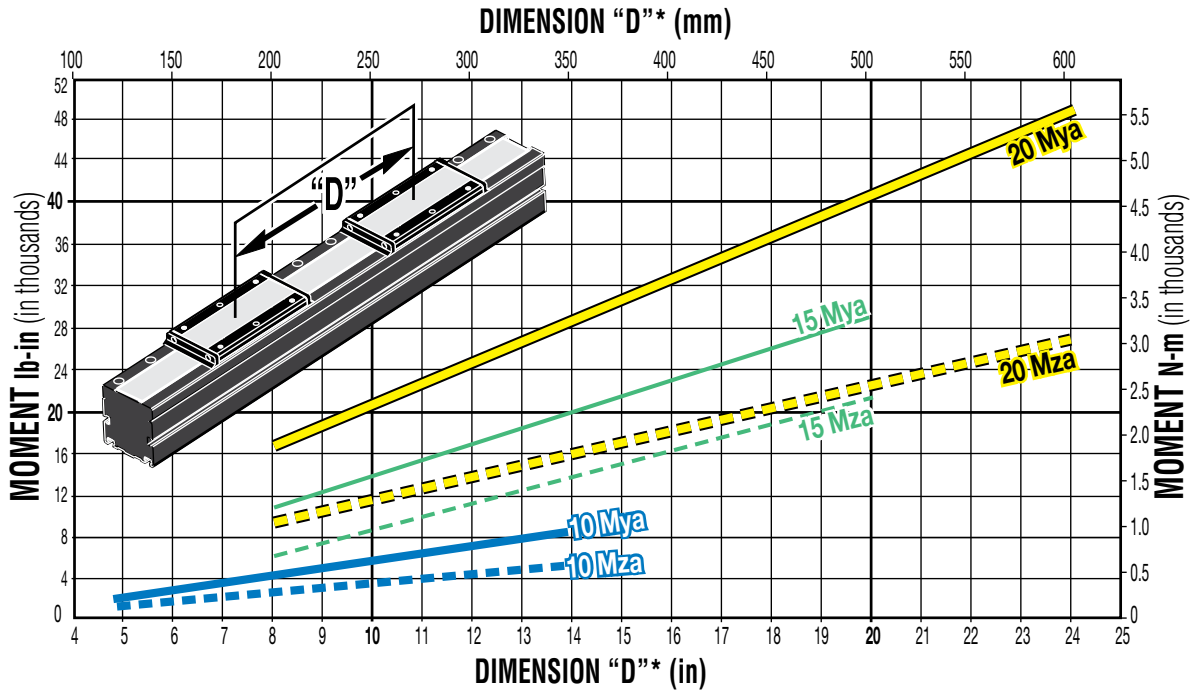

AUXILIARY DUAL 180° CARRIER: BENDING MOMENT AT 'D' DISTANCE

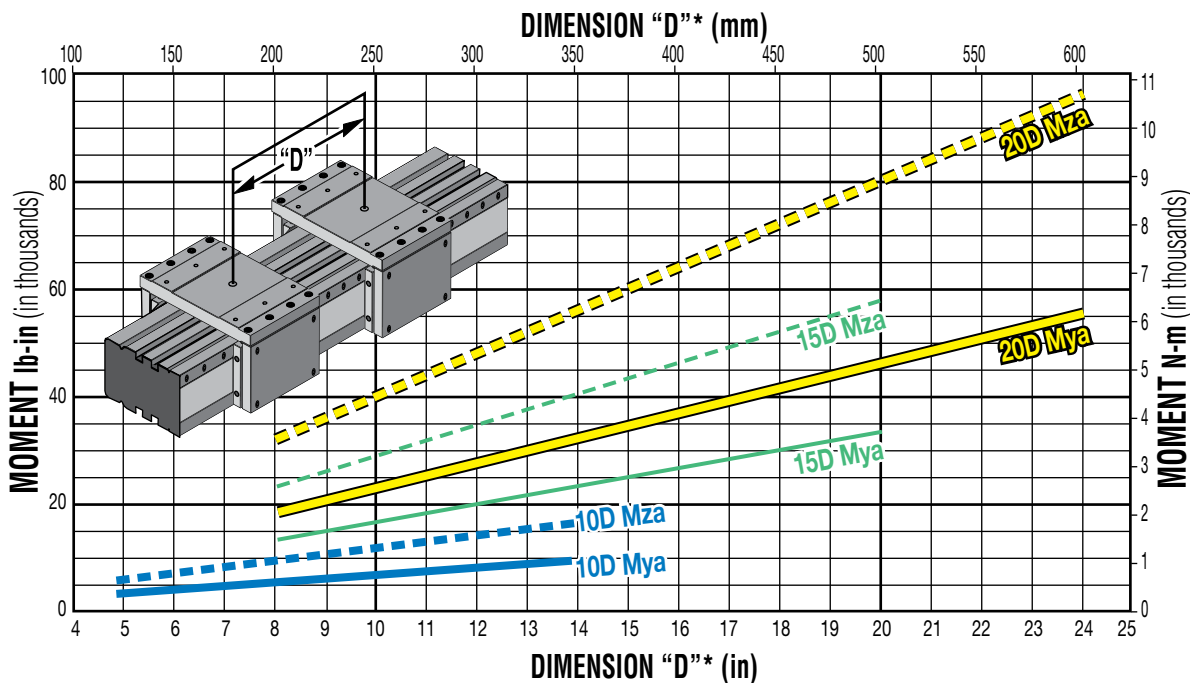

Rates shown on both graphs were calculated with these assumptions:

- 1.) Coupling between carriers is rigid.
- 2.) Load is equally distributed between carriers.
- 3.) Coupling device applies no misalignment loads to carriers.

* Customer must specify Dimension "D" (Distance between carrier center lines) when ordering.

Life of the actuator will vary for each application depending on the combined loads, motion parameters and operating conditions. The load factor (L_f) ratios for each application must not exceed a value of 1.5 (see formula at right). Exceeding a load factor of 1.5 will diminish the actuator's rated life.

$$L_f = \frac{M_x}{M_{x_{max}}} + \frac{M_y}{M_{y_{max}}} + \frac{M_z}{M_{z_{max}}} + \frac{F_y}{F_{y_{max}}} + \frac{F_z}{F_{z_{max}}} \leq 1.5$$

With combined loads, L_f must not exceed the value 1.5

B3S Electric Screw Drive Rodless Actuators



SPECIFICATIONS Related to Actuator Size and Screw Selection

INCH (US Conventional) LEAD SCREWS

	SCREW DIA. (in)	SCREW TYPE	TPI (turns/in)	LEAD ACCURACY (in/ft)	BACKLASH (in)	MAX THRUST* (lbf)	MAX STROKE (in)	INERTIA (lb-in ²)			BREAKAWAY TORQUE (lb-in)
								BASE ACTUATOR		PER/in OF STROKE	
								In Line	Rev. Parallel		
B3S10	0.375	BN	08	0.004	0.015	130	64.2	0.0034	0.0042	0.0005	1.125
	0.375	BNL	08	0.004	0.002	130	64.2	0.0034	0.0042	0.0005	1.125
	0.500	SN	05	0.006	0.007	170	136.2	0.0114	0.0142	0.0017	1.250
	0.500	SN	02	0.005	0.007	170	134.2	0.0159	0.0187	0.0017	1.750
	0.500	SNA	02	0.005	0.003	170	134.2	0.0193	0.0221	0.0017	1.750
	0.500	SN	01	0.006	0.007	170	100.2	0.0320	0.0348	0.0017	2.500
B3S15	0.500	BN	02	0.003	0.015	800	61.4	0.0253	0.0282	0.0017	1.563
	0.500	BNL	02	0.003	0.002	800	61.4	0.0253	0.0282	0.0017	1.563
	0.625	SN	02	0.005	0.007	200	133.4	0.0480	0.0550	0.0042	1.875
	0.625	SNA	02	0.005	0.003	200	133.4	0.0480	0.0550	0.0042	1.875
	0.625	BN	05	0.003	0.015	800	61.4	0.0397	0.0467	0.0042	1.250
	0.625	BNL	05	0.003	0.002	800	61.4	0.0397	0.0467	0.0042	1.250
	0.750	SN	01	0.005	0.007	300	133.4	0.1185	0.1329	0.0087	2.813
B3S20	0.750	SN	02	0.005	0.007	300	131.4	0.1159	0.1224	0.0087	3.438
	0.750	SN	01	0.005	0.007	300	131.4	0.1565	0.1630	0.0087	5.000
	0.750	BN	02	0.004	0.015	2700	179.4	0.1159	0.1224	0.0087	3.125
	0.750	BNL	02	0.004	0.002	2700	179.4	0.1159	0.1224	0.0087	3.125
	0.750	BN	05	0.003	0.015	950	131.4	0.1045	0.1110	0.0087	2.188
	0.750	BNL	05	0.003	0.002	950	131.4	0.1045	0.1110	0.0087	2.188

METRIC LEAD SCREWS

	SCREW DIA. (mm)	SCREW TYPE	LEAD (mm/turn)	LEAD ACCURACY (mm/300)	BACKLASH (mm)	MAX THRUST* (N)	MAX STROKE (mm)	INERTIA (kg-m ² x 10 ⁻⁹)			BREAKAWAY TORQUE (lb-in)
								BASE ACTUATOR		PER/in OF STROKE	
								In Line	Rev. Parallel		
M3S10	10	BN	2.5	0.13	0.38	800	1630	1.14	1.43	0.176	0.13
	10	BNL	2.5	0.13	0.05	800	1630	1.14	1.43	0.176	0.13
	12	SN	12.0	0.13	0.18	800	3459	3.03	4.50	0.410	0.20
	12	SN	25.0	0.13	0.18	800	1630	8.54	9.21	0.410	0.28
M3S15	15	SN	12.0	0.13	0.18	900	3388	11.35	12.96	0.966	0.27
	16	BN	5.0	0.13	0.38	7300	3388	11.93	14.04	1.258	0.16
	16	BNL	5.0	0.13	0.05	7300	3388	11.93	14.04	1.258	0.16
	19	SN	25.0	0.13	0.18	1400	3388	34.05	38.26	2.517	0.32
M3S20	19	SN	12.0	0.13	0.18	1400	3337	44.96	35.04	2.517	0.39
	19	SN	25.0	0.13	0.18	1400	3337	33.14	46.86	2.517	0.57
	20	BN	5.0	0.13	0.38	11700	3337	36.97	39.28	3.102	0.25
	20	BNL	5.0	0.13	0.05	11700	3337	36.97	39.28	3.102	0.25

SCREW CODE	DESCRIPTION
SN	Solid Nut
SNA	Anti-backlash Solid Nut
BN	Ball Nut
BNL	Low-Backlash Ball Nut

Contact Tolomatic for higher accuracy and lower backlash options.
 * For Acme screws, maximum thrust is the maximum continuous dynamic thrust subject to Thrust x Velocity limitation.
 For ball screws, maximum thrust reflects 90% reliability for 1 million linear inches of travel.

B3S Electric Screw Drive Rodless Actuators

SPECIFICATIONS



INCH (US Conventional)

	WEIGHT		WEIGHT PER UNIT OF STROKE	¹ STRAIGHTNESS & FLATNESS (supported)	² TEMPERATURE RANGE	³ IP RATING
	CARRIER (lbs)	BASE (lbs)				
B3S10	0.85	2.15	0.30	0.00067 x L*	40 - 130	44
B3S15	1.56	8.75	0.57			
B3S20	2.15	14.38	0.88			

METRIC

	(kg)	(kg)	(g/mm)	(mm)	(°C)	³ IP RATING
M3S10	0.40	1.00	5.40	0.00067 x L*	4 - 54	44
M3S15	0.70	3.96	10.18			
M3S20	0.97	6.52	15.73			



¹ The listed values relating to straightness/flatness are intended for reference purposes only, and not as an engineering standard of absolute tolerance for a given actuator. Appropriate installation is the single most important factor in reducing such deviation, so good engineering practices such as measurement, mapping, etc. must be employed in applications with stringent straightness/flatness requirements.

² Heat generated by the motor and drive should be taken into consideration as well as linear velocity and work cycle time. For applications that require operation outside of the recommended temperature range, contact the factory.

³ Protected against ingress of solid particles greater than .039 in (1mm) and splashing water.

* "L" is maximum distance between supports— See the support recommendation graph on page B3_9.

LARGE FRAME MOTORS AND SMALLER SIZE ACTUATORS: Cantilevered motors need to be supported, if subjected to continuous rapid reversing duty and/or under dynamic conditions.

LEAD SCREW EFFICIENCY

SCREW/NUT STYLE	SIZE		
	10	15	20
Composite (ACME)	0.60		
Ball	0.90		
Ball Low Backlash	0.85		

B3S

B3W

B3S Electric Screw Drive Rodless Actuators

ACME SCREW/NUT COMBINATIONS



ACME SCREW CRITICAL SPEED CAPACITIES

INCH (US Conventional) ACME SCREW

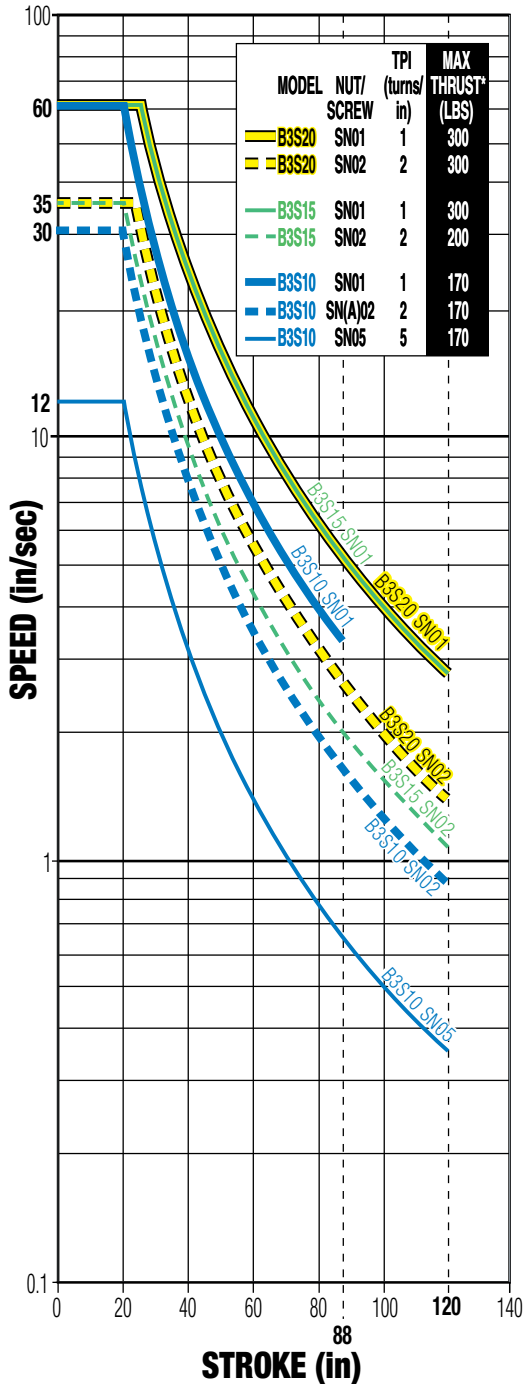

METRIC ACME SCREW

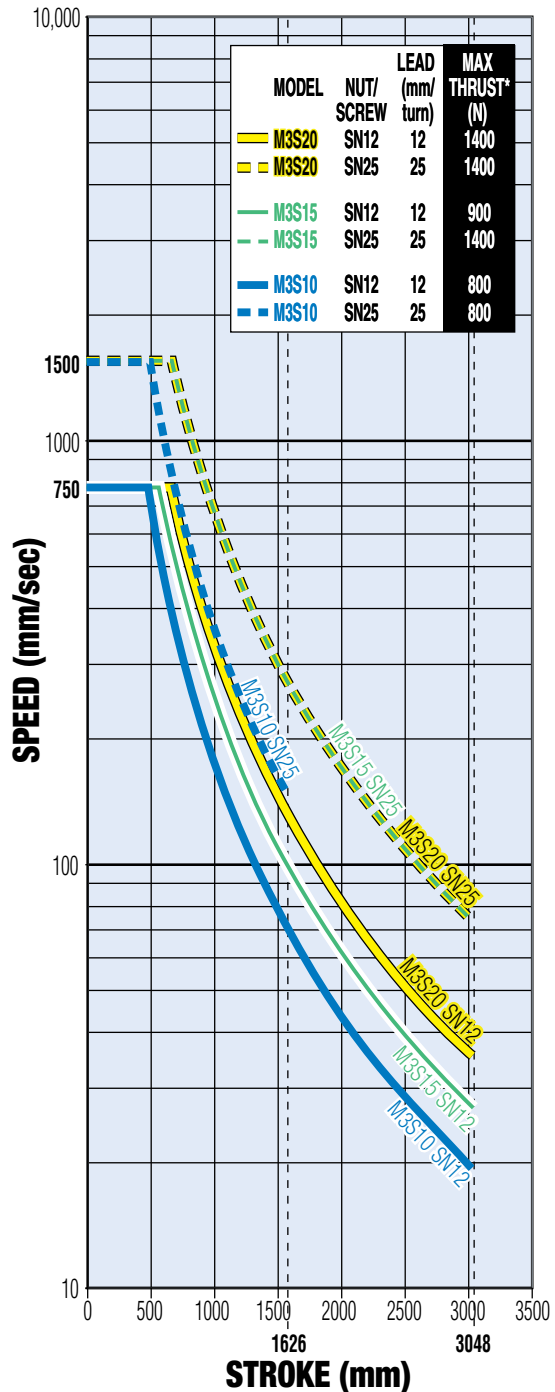

* Maximum thrust is the maximum continuous dynamic thrust subject to Thrust x Velocity limitation.

Dotted lines represent maximum stroke for screw selections.

For Screw PV limits, refer to the individual charts located in the technical section for each actuator body size.

SCREW CODE DESCRIPTION

SN Solid Nut

SNA Anti-backlash Solid Nut

B3S

B3W

B3S Electric Screw Drive Rodless Actuators

ACME SCREW/NUT COMBINATIONS



ACME SCREW PV LIMITS

INCH (US Conventional) ACME SCREW

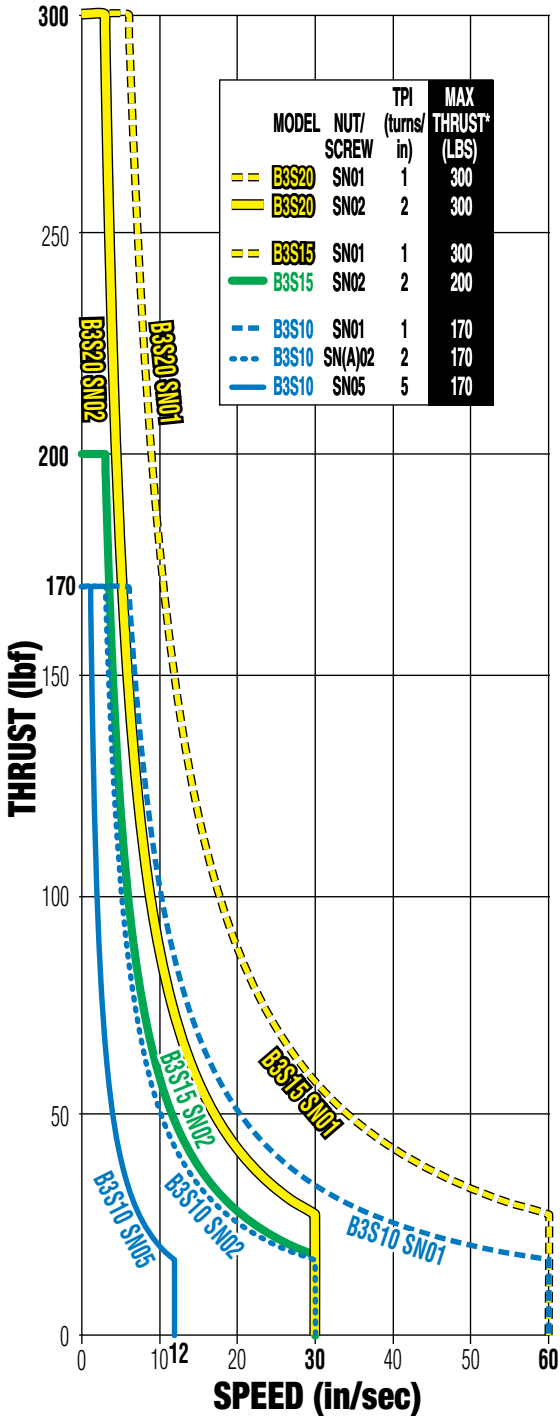

METRIC ACME SCREW

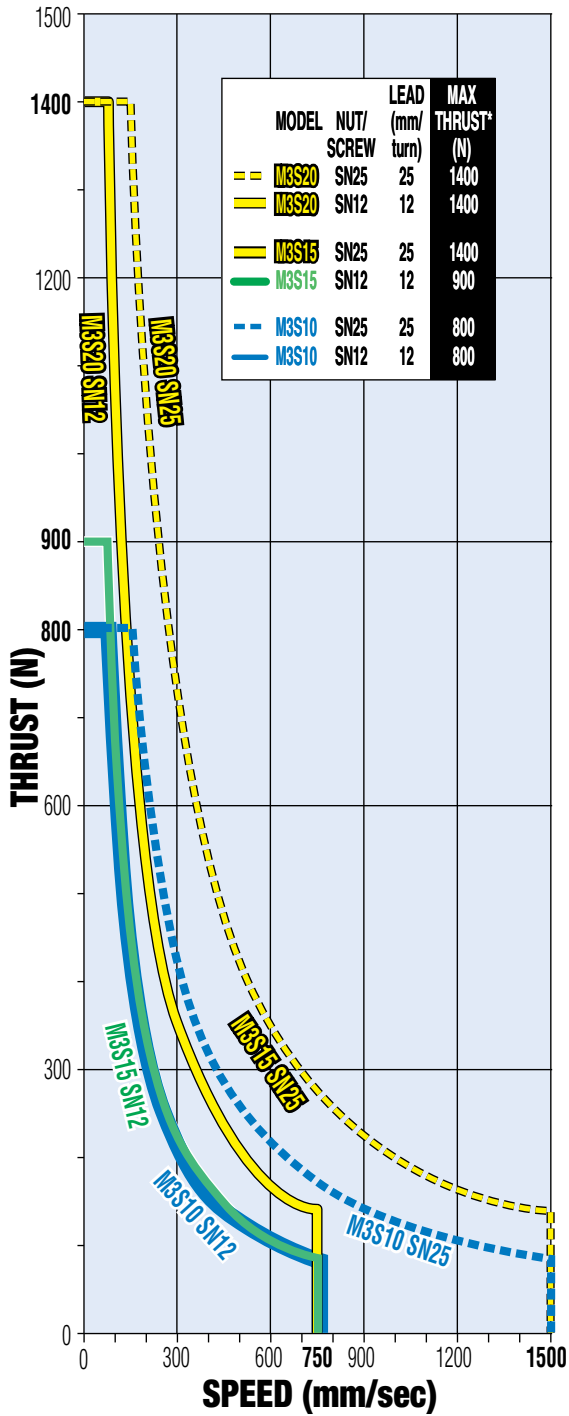

▲ * Maximum thrust is the maximum continuous dynamic thrust subject to Thrust x Velocity Limitation.

PV LIMITS: Any material which carries a sliding load is limited by heat buildup. The factors that affect heat generation rate in an application are the pressure on the nut in pounds per square inch and the surface velocity in feet per minute. The product of these factors provides a measure of the severity of an application.

$$\frac{P}{(\text{Max. Thrust Rating})} \times \frac{V}{(\text{Max. Speed Rating})} \leq 0.1$$

B3S Electric Screw Drive Rodless Actuators

BALL SCREW/NUT COMBINATIONS



BALL SCREW CRITICAL SPEED CAPACITIES

INCH (US Conventional) BALL SCREW

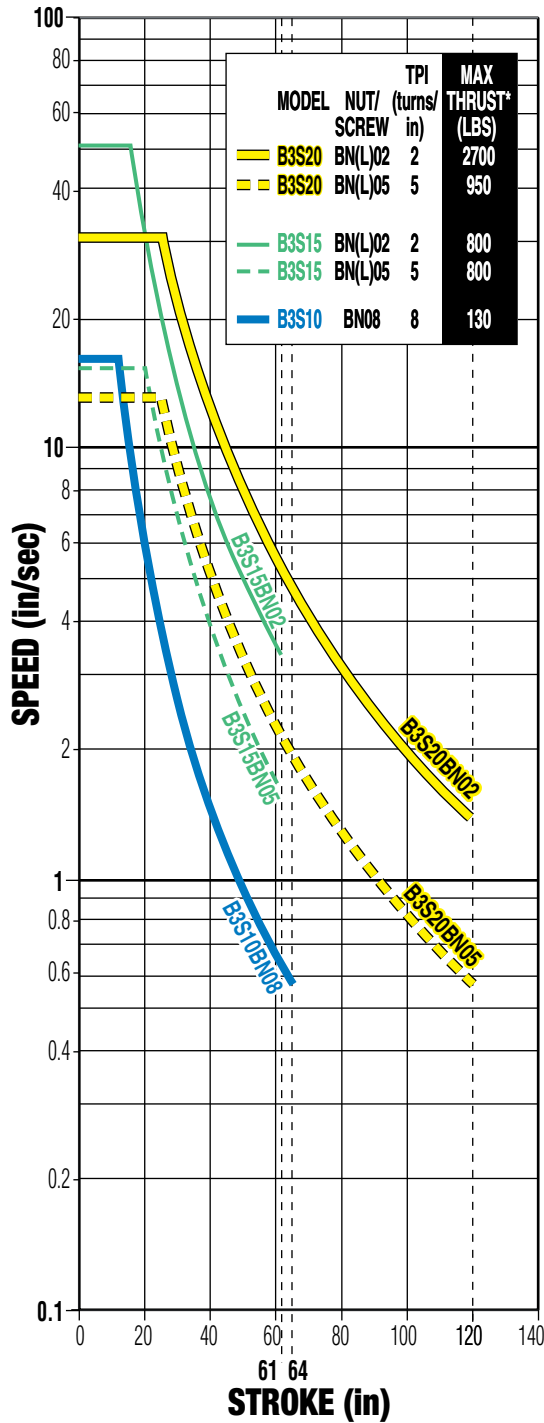

METRIC BALL SCREW

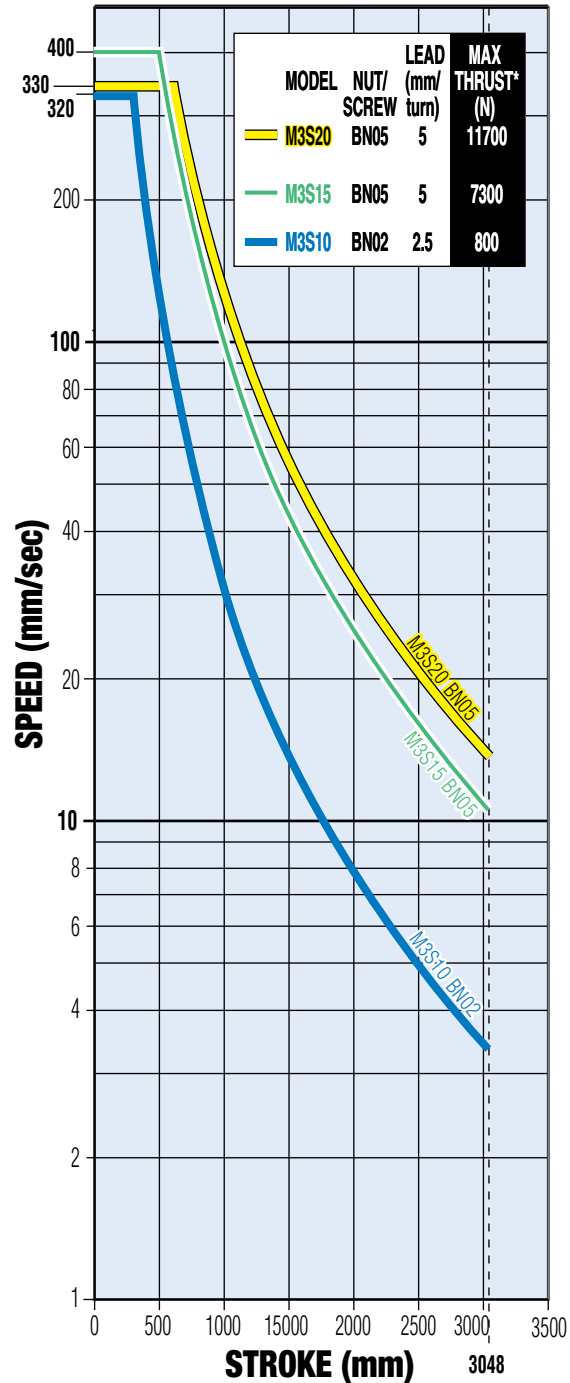

! * Maximum thrust reflects 90% reliability for 1 million linear inches of travel.
Dotted lines represent maximum stroke for screw selections.

SCREW CODE	DESCRIPTION
BN	Ball Nut
BNL	Low-Backlash Ball Nut

B3S

B3W

B3S Electric Screw Drive Rodless Actuators

BALL SCREW/NUT COMBINATIONS



BALL SCREW LIFE CAPACITIES

INCH (US Conventional) BALL SCREW

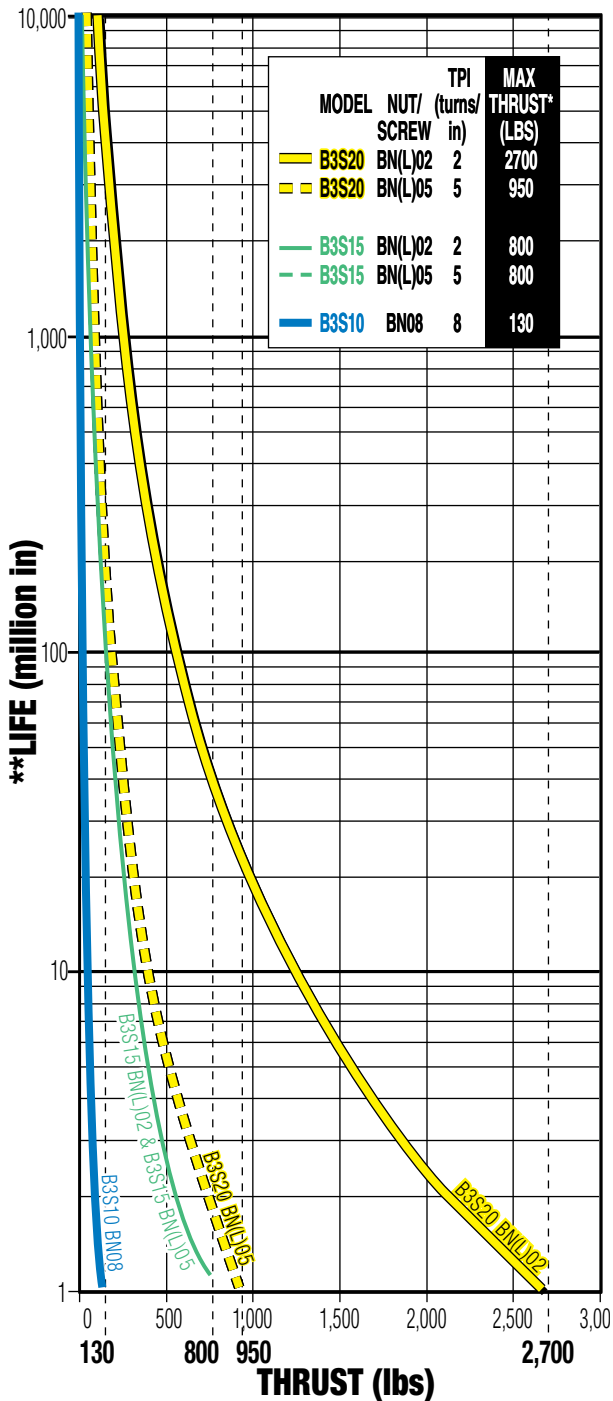

METRIC BALL SCREW

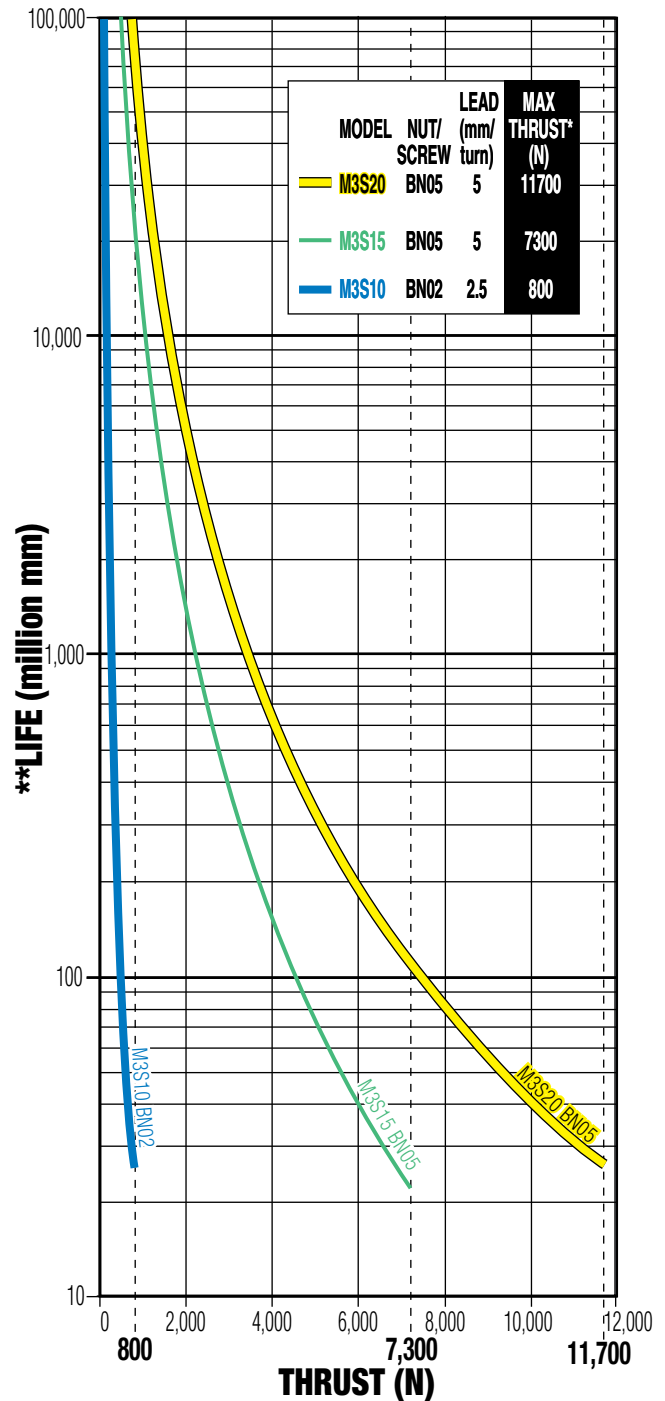

! * Maximum thrust reflects 90% reliability for 1 million lineal meters of travel.

Dotted lines represent maximum thrust for screw selections.

**Life indicates theoretical maximum life of screw only, under ideal conditions and does not indicate expected life of actuator.

B3S10 Electric Screw Drive Rodless Actuators

DIMENSIONS Actuator & Options

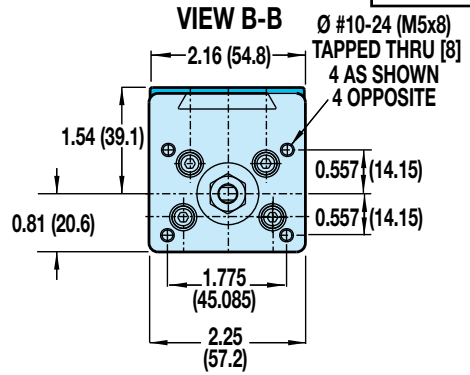
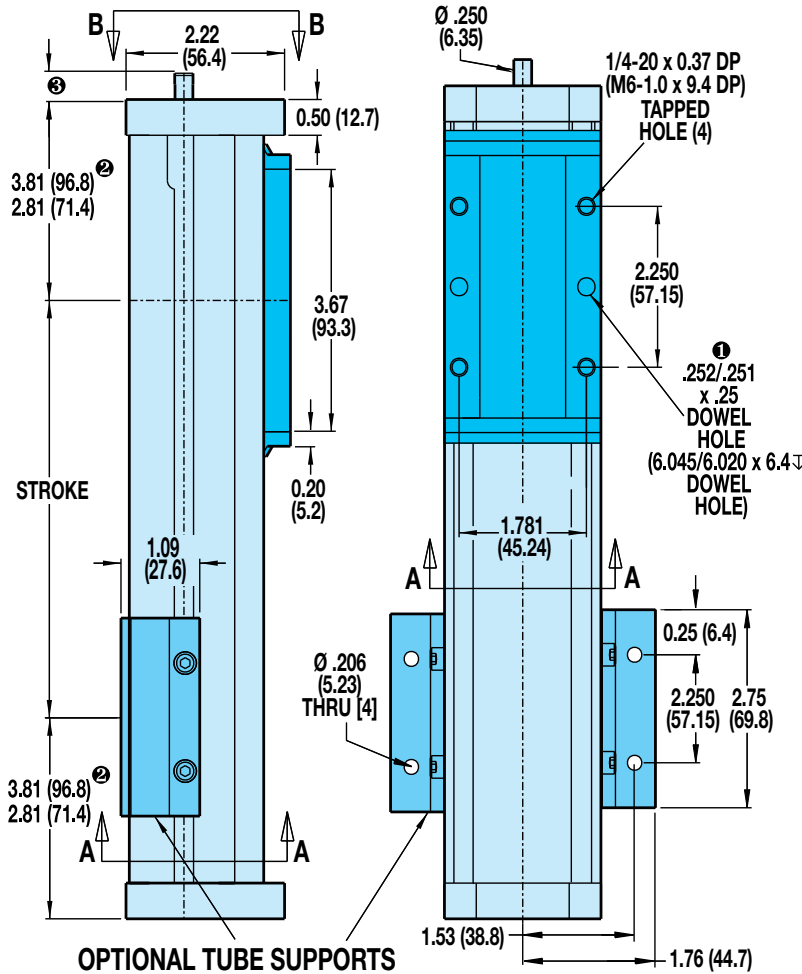

MOTOR MOUNTING

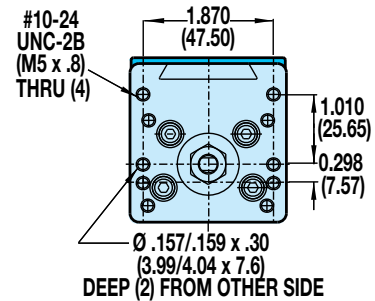

OPTIONAL TUBE SUPPORTS

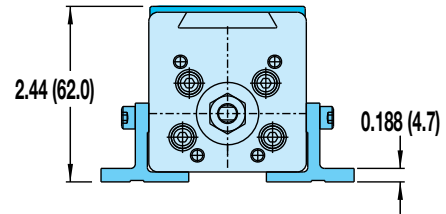

SILVER NUTS FOR SLOTS 90° FROM CARRIER

#3410-1013 [4410-1013]

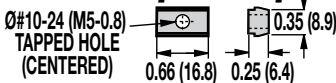

YELLOW NUTS FOR SLOTS OPPOSITE CARRIER

#3410-1775 [4410-1708]

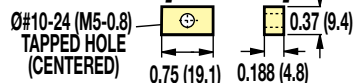

OPTIONAL SWITCH MOUNTING

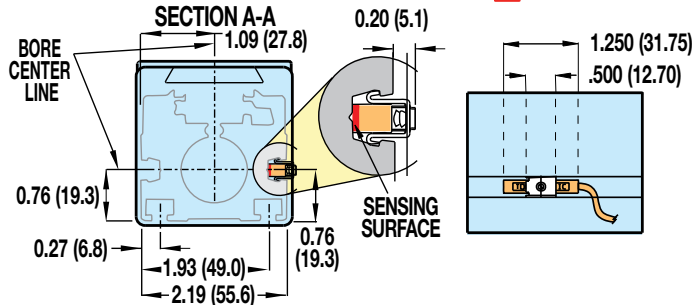

OPTIONAL MOUNTING PLATES

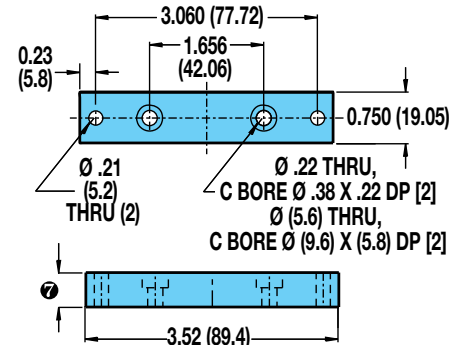

① DOWEL PINS $\varnothing .003$ (08mm) \textcircled{M}

② FOR SNAO2 STYLE ONLY

③ SHAFT LENGTH

In-line mounting	0.55 (13.8)
Extended shaft for RP & 23-frame motor	1.99 (50.5)
Extended shaft for RP & 34-frame motor	2.20 (55.9)
Extended shaft for purchases prior to 6/24/02	1.63 (41.4)

⚠ CAUTION: DO NOT OVERTIGHTEN SWITCH HARDWARE WHEN INSTALLING

⑤ NOTE: The scored face of the switch indicates the sensing surface and must face toward the magnet

⑥ NOTE: Some actuators require switch mounting on a specific side of the actuator. Call Tolomatic 1-800-328-2174 for details

⑦ LMI with MRS is 1" (25.4mm) thick
 LMI with all others is 1/2" (12.7mm) thick
 RP, (YMH) all motors is 1/2" (12.7mm) thick

Unless otherwise noted, all dimensions shown are in inches (Dimensions in parenthesis are in millimeters)

B3S10 Electric Screw Drive Rodless Actuators

DIMENSIONS Dual 180° Option

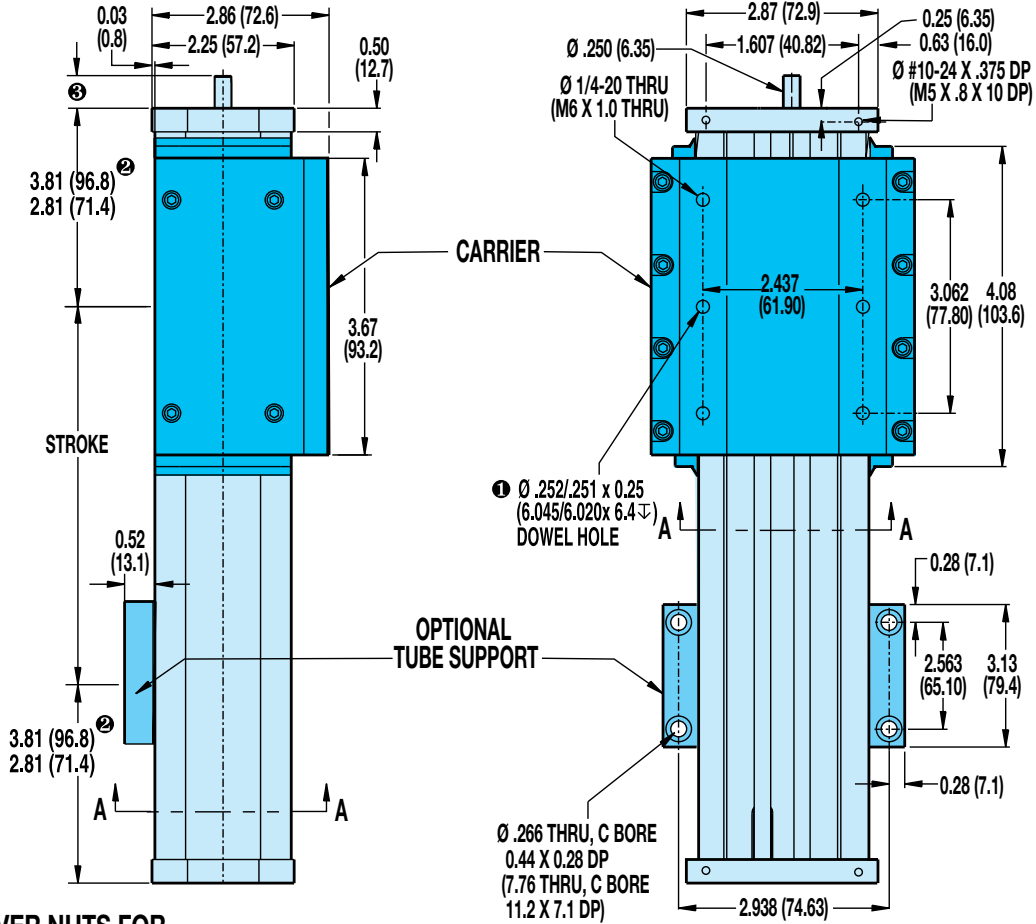

SILVER NUTS FOR SLOTS 90° FROM CARRIER #3410-1013 [4410-1013]

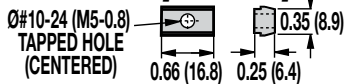

OPTIONAL SWITCH MOUNTING ⚠️ ⚡️ ⚙️

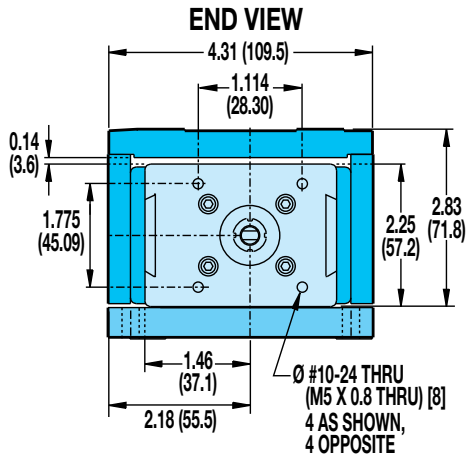
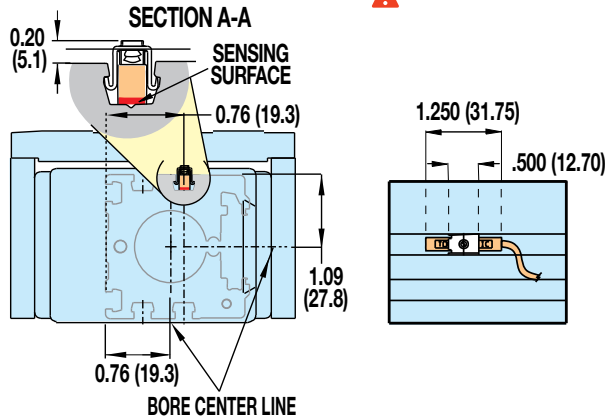

① DOWEL PINS \oplus .003 (08mm) M

② FOR SNA02 STYLE ONLY

③ SHAFT LENGTH

In-line mounting	0.55 (13.8)
Extended shaft for RP & 23-frame motor	1.99 (50.5)
Extended shaft for RP & 34-frame motor	2.20 (55.9)
Extended shaft for purchases prior to 6/24/02	1.63 (41.4)

⚠️ **CAUTION: DO NOT OVERTIGHTEN SWITCH HARDWARE WHEN INSTALLING**

⚡️ **NOTE: The scored face of the switch indicates the sensing surface and must face toward the magnet**

⚙️ **NOTE: Some actuators require switch mounting on a specific side of the actuator. Call Tolomatic 1-800-328-2174 for details**

B3S15 Electric Screw Drive Rodless Actuators

DIMENSIONS Actuator & Options

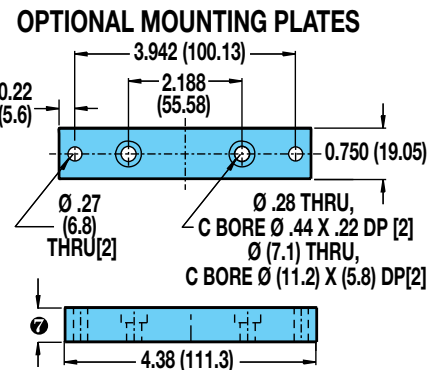
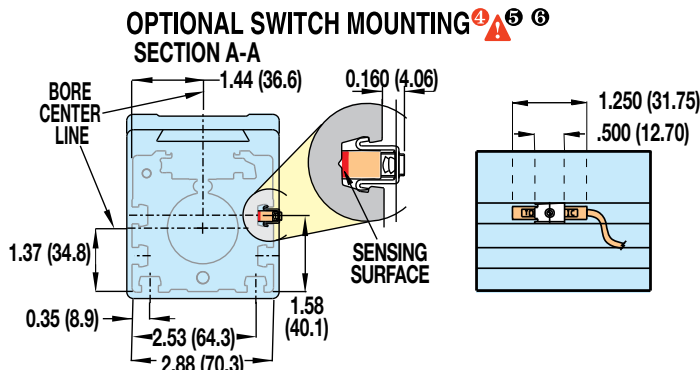
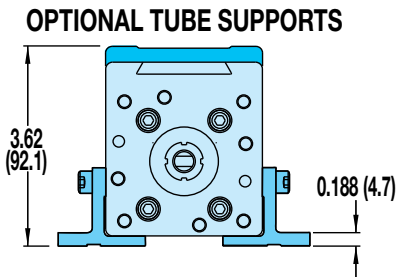
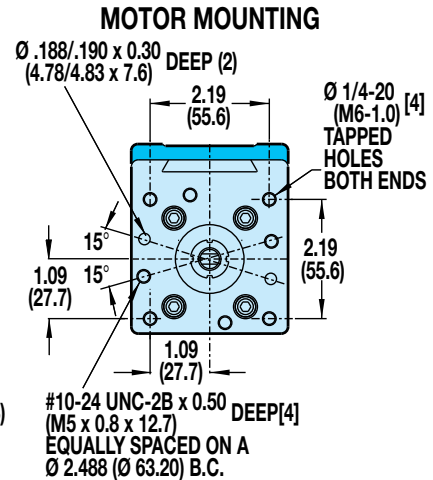
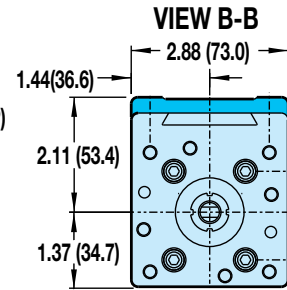
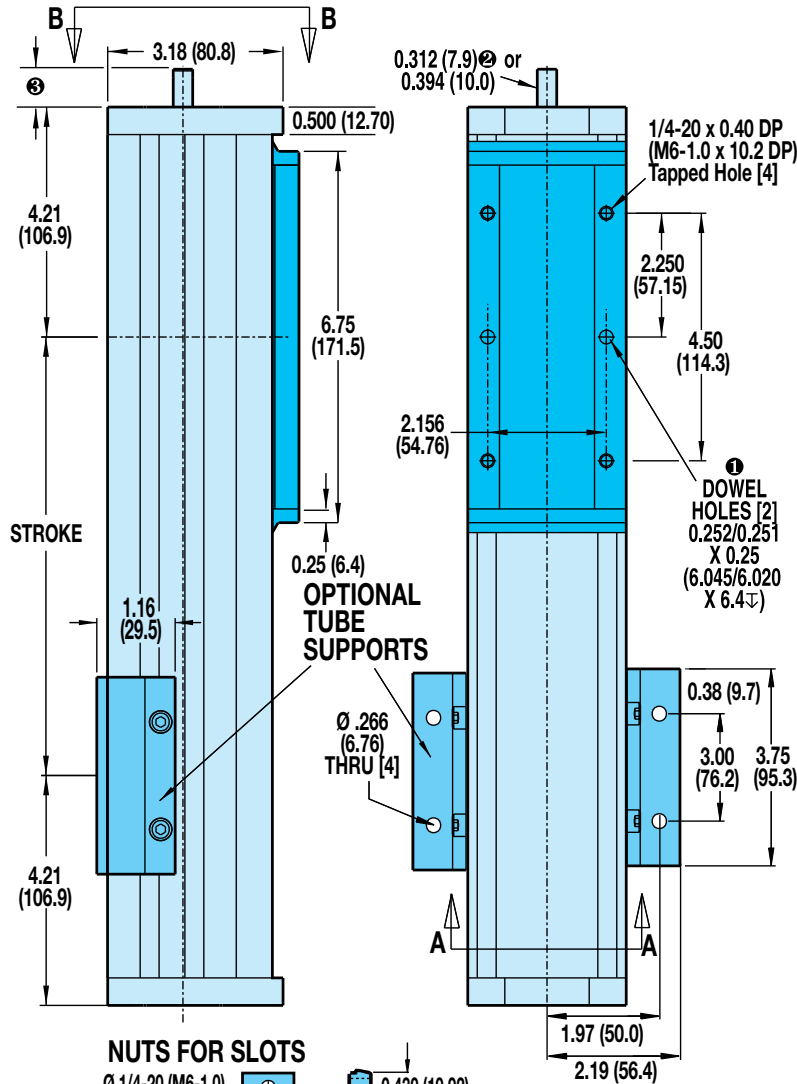

① DOWEL PINS $\pm .003$ (0.08mm) (M)

② FOR B3S15BN02 & B3S15BNL02

③ SHAFT LENGTH

In-line mounting	0.69 (17.5)
Extended shaft for RP & 23-frame motor	1.99 (50.5)
Extended shaft for RP & 34-frame motor	2.20 (55.9)
Extended shaft for purchases prior to 6/24/02	1.95 (49.5)

⚠️ **CAUTION: DO NOT OVERTIGHTEN SWITCH HARDWARE WHEN INSTALLING**

⚡️ **NOTE:** The scored face of the switch indicates the sensing surface and must face toward the magnet

⑥ **NOTE:** Some actuators require switch mounting on a specific side of the actuator. Call Tolomatic 1-800-328-2174 for details

⑦ **LMI with MRS3 is 1" (25.4mm) thick**
LMI with all others is 1/2" (12.7mm) thick
RP, (YMH) all motors is 1/2" (12.7mm) thick

Unless otherwise noted, all dimensions shown are in inches (Dimensions in parenthesis are in millimeters)

B3S15 Electric Screw Drive Rodless Actuators

DIMENSIONS Dual 180° Option

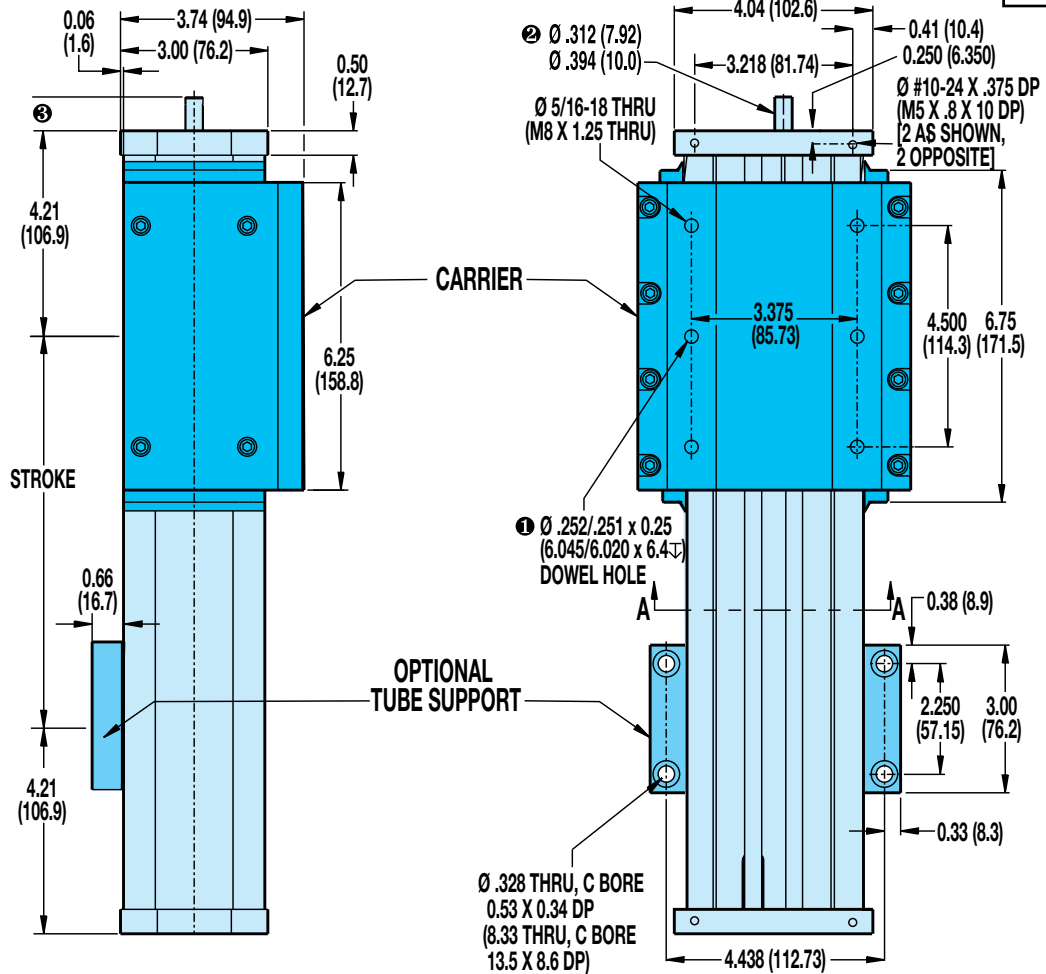

NUTS FOR SLOTS

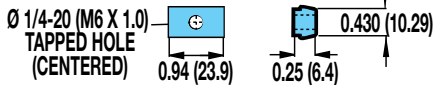

OPTIONAL SWITCH MOUNTING

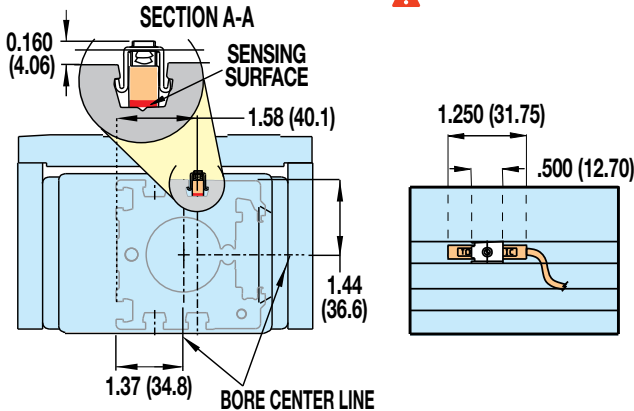

END VIEW

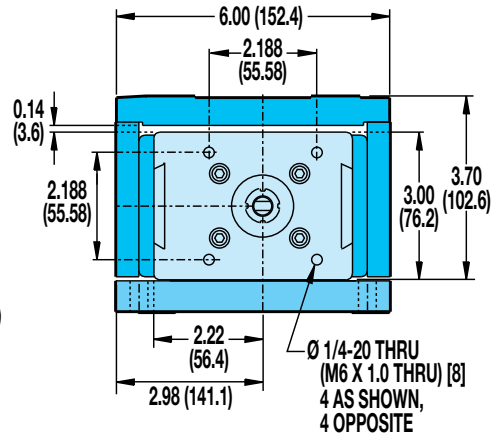

1 DOWEL PINS

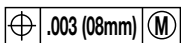

2 FOR B3S15BN02 & B3S15BNL02

3 SHAFT LENGTH

In-line mounting	0.69 (17.5)
Extended shaft for RP & 23-frame motor	1.99 (50.5)
Extended shaft for RP & 34-frame motor	2.20 (55.9)
Extended shaft for purchases prior to 6/24/02	1.95 (49.5)

4 CAUTION: DO NOT OVERTIGHTEN SWITCH HARDWARE WHEN INSTALLING

5 NOTE: The scored face of the switch indicates the sensing surface and must face toward the magnet

6 NOTE: Some actuators require switch mounting on a specific side of the actuator. Call Tolomatic 1-800-328-2174 for details

B3S20 Electric Screw Drive Rodless Actuators

DIMENSIONS Actuator & Options

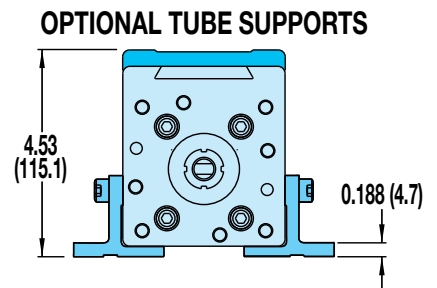
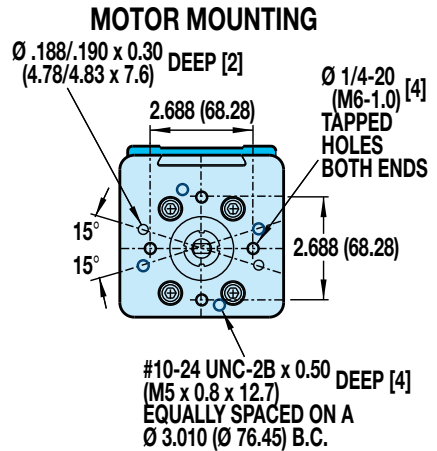
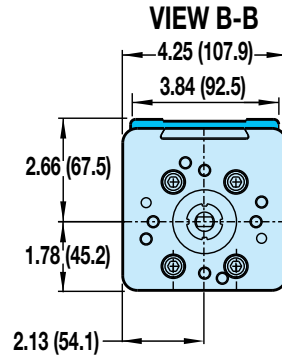
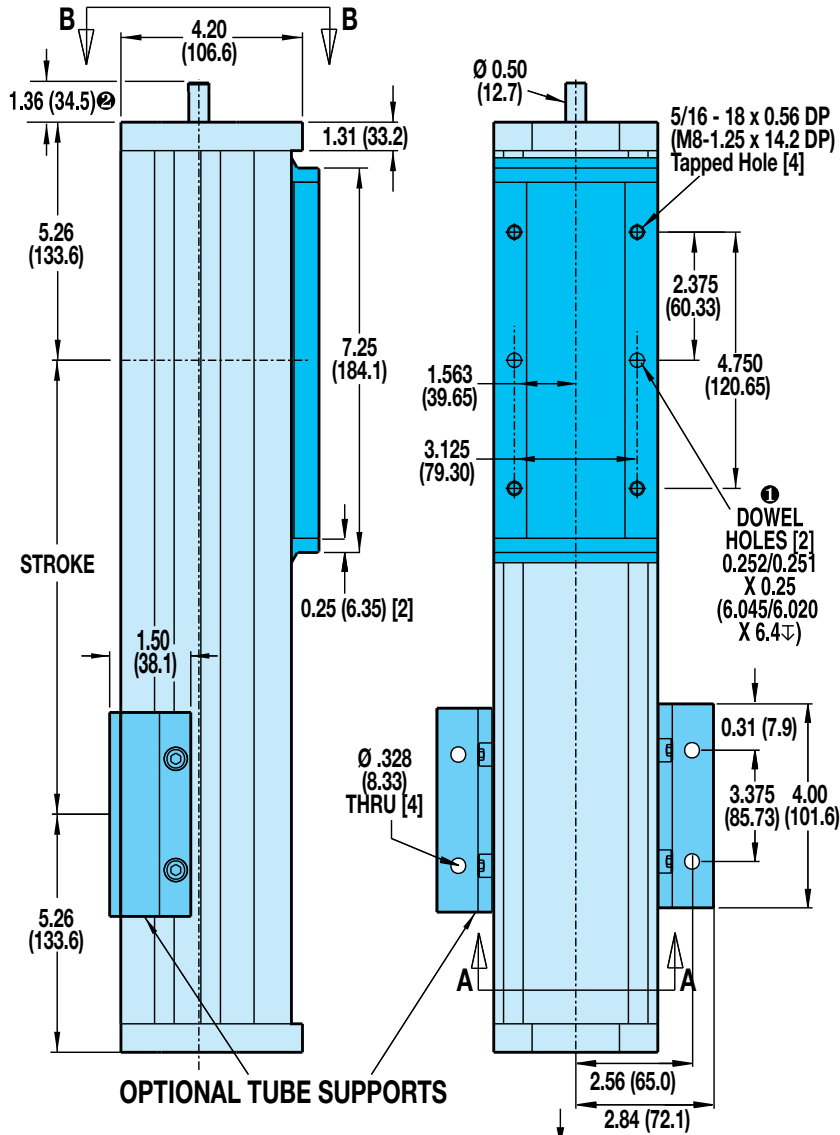

OPTIONAL TUBE SUPPORTS



OPTIONAL SWITCH MOUNTING

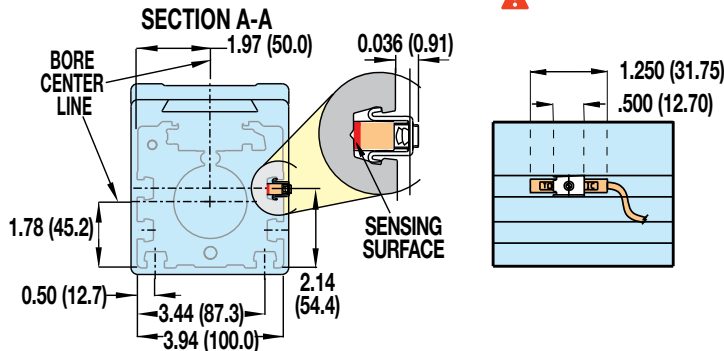

OPTIONAL MOUNTING PLATES

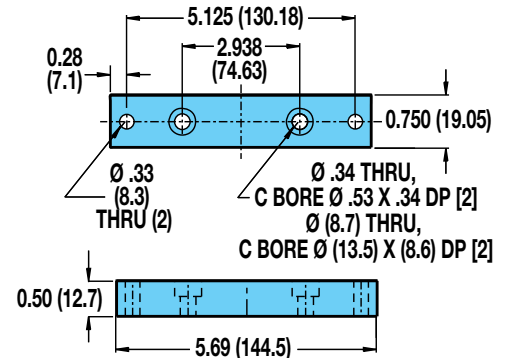

- 1 DOWEL PINS $Ø .003$ (08mm) (M)
- 2 FOR EXTENDED SHAFT 2.11 (53.6)

3 **CAUTION: DO NOT OVERTIGHTEN SWITCH HARDWARE WHEN INSTALLING**

4 NOTE: The scored face of the switch indicates the sensing surface and must face toward the magnet

5 NOTE: Some actuators require switch mounting on a specific side of the actuator. Call Tolomatic 1-800-328-2174 for details

B3S20 Electric Screw Drive Rodless Actuators

DIMENSIONS Dual 180° Option

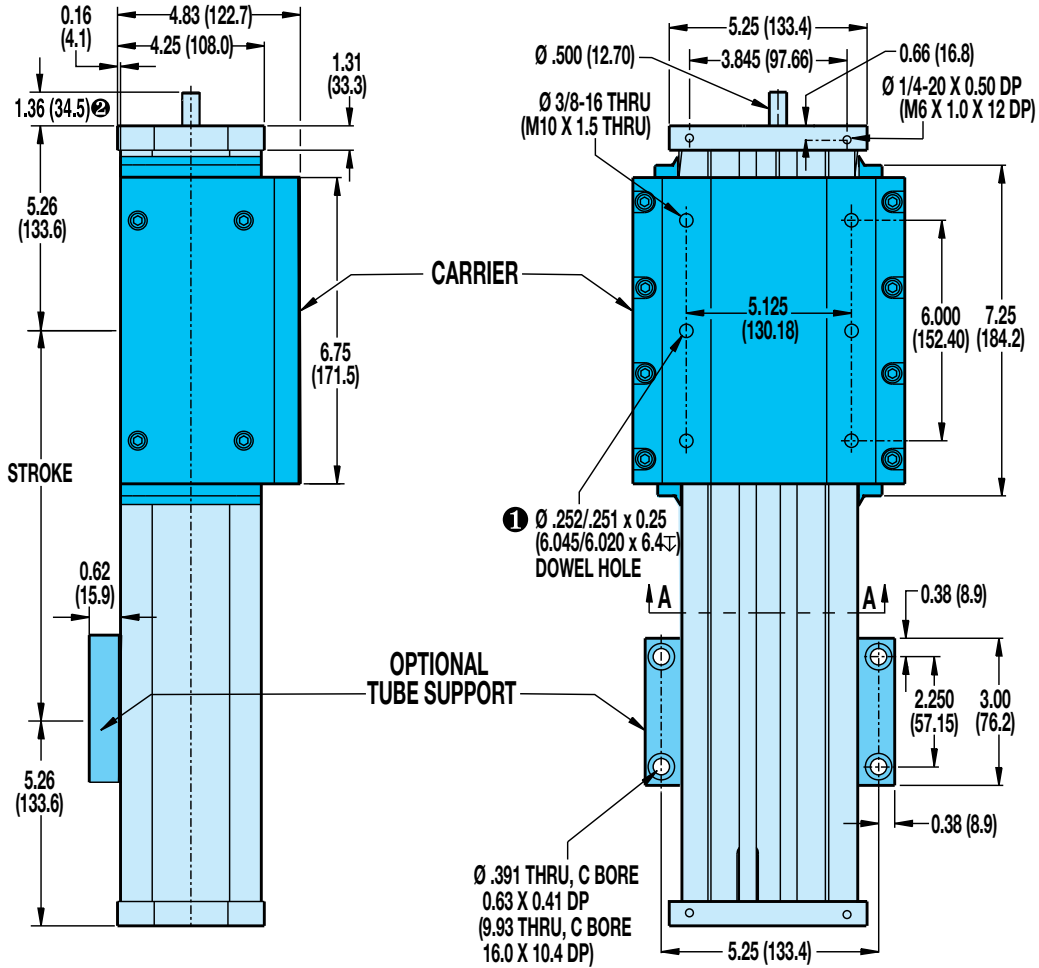

NUTS FOR SLOTS



OPTIONAL SWITCH MOUNTING

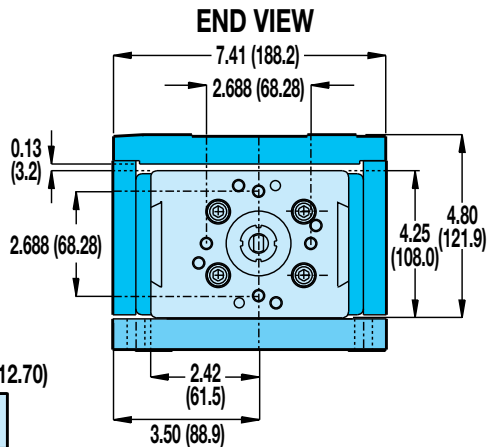
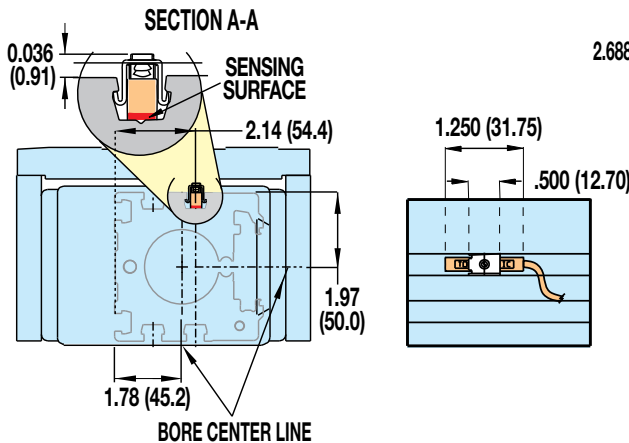

- ① DOWEL PINS $\pm .003$ (08mm) (M)
- ② FOR EXTENDED SHAFT 2.11 (53.6)

- ⚠ CAUTION: DO NOT OVERTIGHTEN SWITCH HARDWARE WHEN INSTALLING
- ④ NOTE: The scored face of the switch indicates the sensing surface and must face toward the magnet

- ⑤ NOTE: Some actuators require switch mounting on a specific side of the actuator. Call Tolomatic 1-800-328-2174 for details

B3S Electric Screw Drive Rodless Actuators

DIMENSIONS Actuator & Options



B3S10/M3S10: IN-LINE MOUNT FOR MOTORS OR GEARBOXES

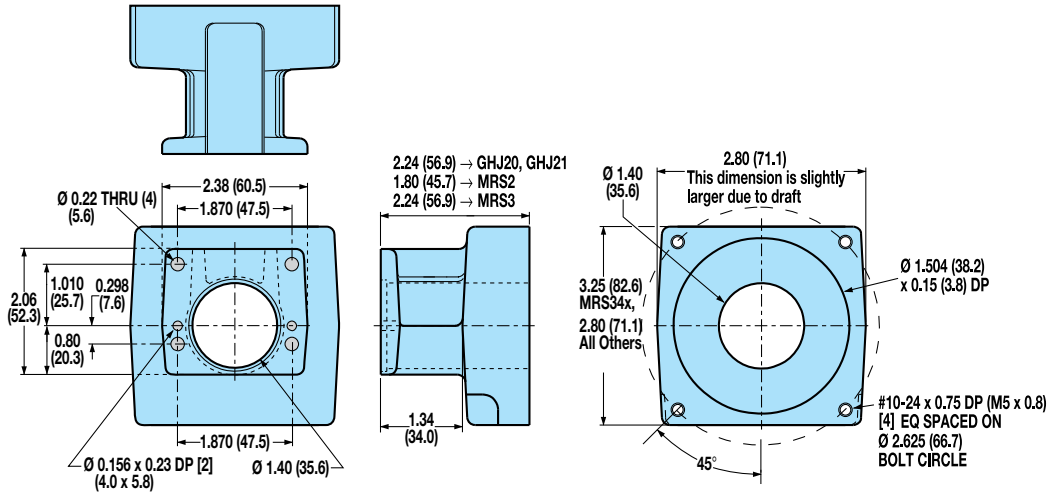

B3S15/M3S15: IN-LINE MOUNT FOR MOTORS OR GEARBOXES

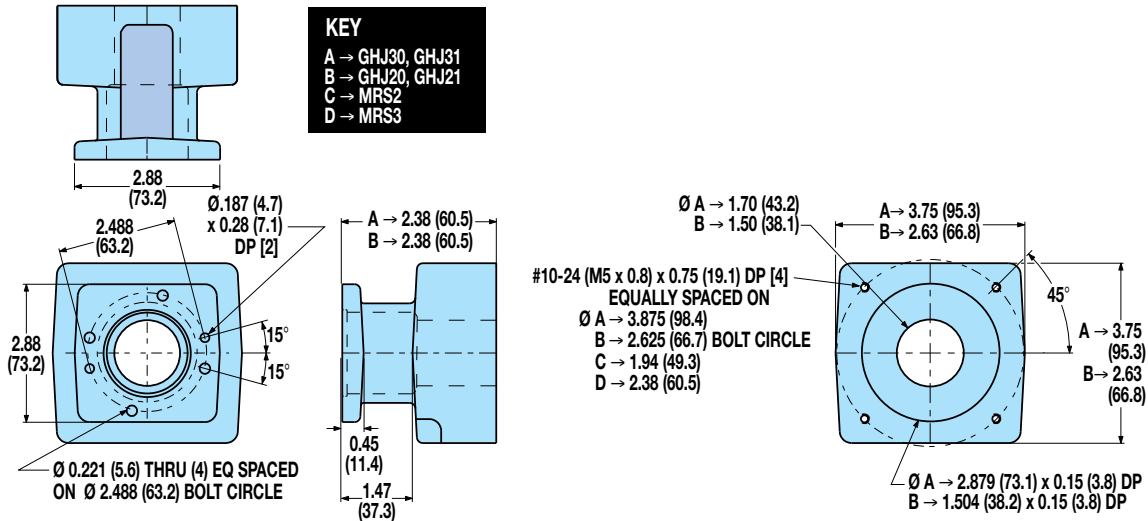

B3S20/M3S20: IN-LINE MOUNT FOR MOTORS OR GEARBOXES

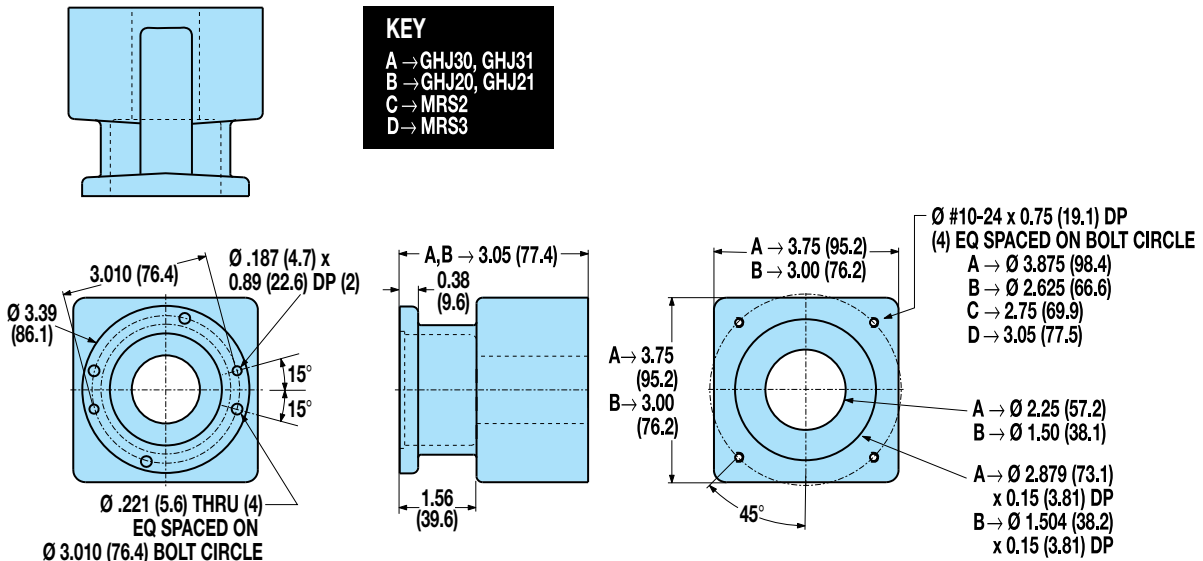

B3S Electric Screw Drive Rodless Actuators

DIMENSIONS Reverse Parallel Mounting



STANDARD CARRIER

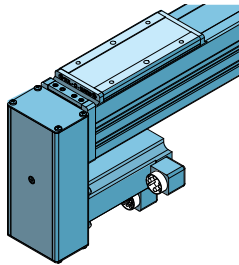

REVERSE-PARALLEL BOTTOM (RPB)
mounting surface shown up

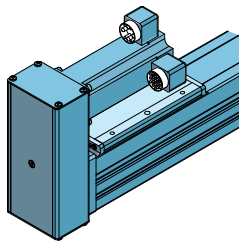

REVERSE-PARALLEL TOP (RPT)*
mounting surface shown up

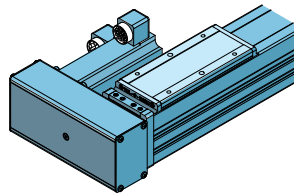

REVERSE-PARALLEL LEFT (RPL)
mounting surface shown up

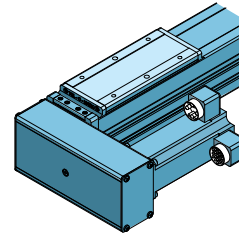

REVERSE-PARALLEL RIGHT (RPR)
mounting surface shown up

BOTTOM MOUNT

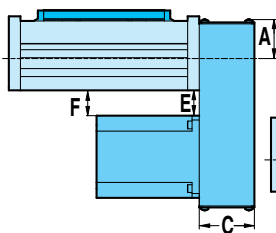

TOP MOUNT

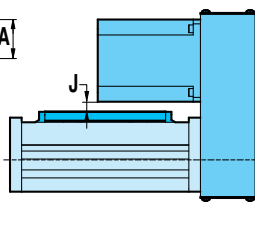

SIDE MOUNT (Right Shown)

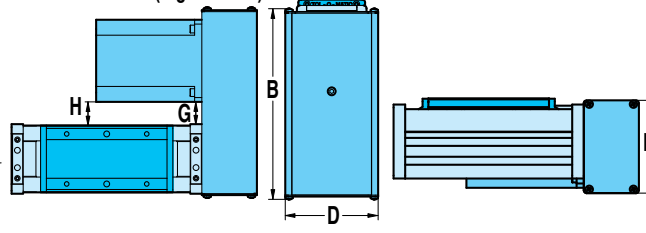

DUAL 180° CARRIER

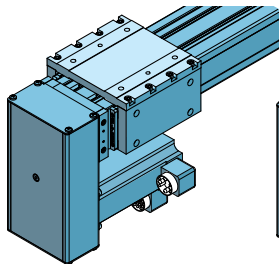

REVERSE-PARALLEL BOTTOM (RPB)
mounting surface shown up

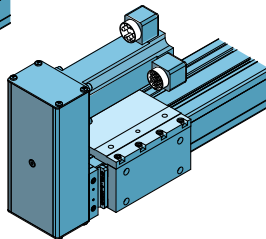

REVERSE-PARALLEL TOP (RPT)*
mounting surface shown up

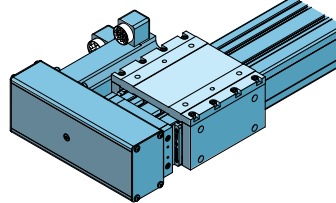

REVERSE-PARALLEL LEFT (RPL)
mounting surface shown up

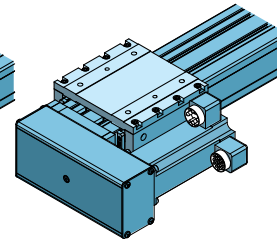

REVERSE-PARALLEL RIGHT (RPR)
mounting surface shown up

Reduction Drive Weight

		lb	kg
10	1:1 & 2:1 Ratio	2.06	0.93
	1:1 Ratio	2.17	0.98
15	2:1 Ratio	2.40	1.09
	1:1 Ratio	3.07	1.39
20	2:1 Ratio	3.23	1.47
	1:1 Ratio	3.13	1.42
	1:1 Ratio	3.29	1.49
	2:1 Ratio	3.29	1.49

Reduction Inertia at Motor Shaft

		lb-in ²	kg-cm ²
10	1:1 Ratio	0.0875	0.2559
	2:1 Ratio	0.1125	0.3291
15	1:1 Ratio	0.0700	0.2043
	2:1 Ratio	0.0950	0.2767
20	1:1 Ratio	0.1180	0.3447
	2:1 Ratio	0.1000	0.2928

*NOTE: RPT is generally not recommended because the load may interfere with the motor. Stops or spacers may be required.

Reduction Efficiency: 0.95

DIMENSIONS

Frame Size	A	B		C		D		E		F		G		H		J			
		in.	mm	in.	mm	in.	mm	in.	mm	in.	mm	in.	mm	in.	mm	in.	mm		
10	23	1.68	42.6	7.03	178.6	2.13	54.0	3.25	82.6	1.80	45.6	1.84	46.8	1.48	37.6	1.51	38.4	1.06	26.9
	34	2.12	53.8	8.21	208.6	2.38	60.3	4.00	101.6	1.09	27.7	1.09	27.7	0.96	24.4	1.02	25.9	0.35	8.9
15	23	1.44	36.6	7.53	191.3	2.13	54.0	3.25	82.6	1.74	44.1	1.74	44.1	1.61	40.8	1.67	42.3	1.00	25.3
	34	2.12	53.8	8.21	208.6	2.38	60.3	4.00	101.6	1.09	27.7	1.09	27.7	0.96	24.4	1.02	25.9	0.35	8.9
20	23	2.51	63.8	9.38	238.4	2.38	60.3	4.00	101.6	2.34	59.5	2.35	59.6	2.00	50.8	2.16	54.7	1.47	37.2
	34	2.51	63.8	9.90	251.5	2.38	60.3	4.00	101.6	1.70	43.2	1.70	43.2	1.36	34.4	1.51	38.4	0.82	20.9

B3W Electric Belt Drive Rodless Actuators



PERFORMANCE

CARRIER SPEED CAPABILITIES

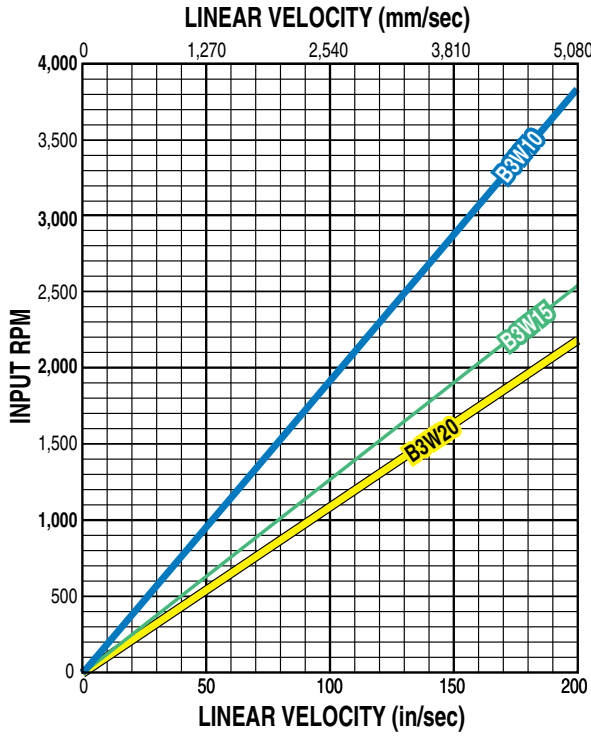

MAXIMUM BELT THRUST

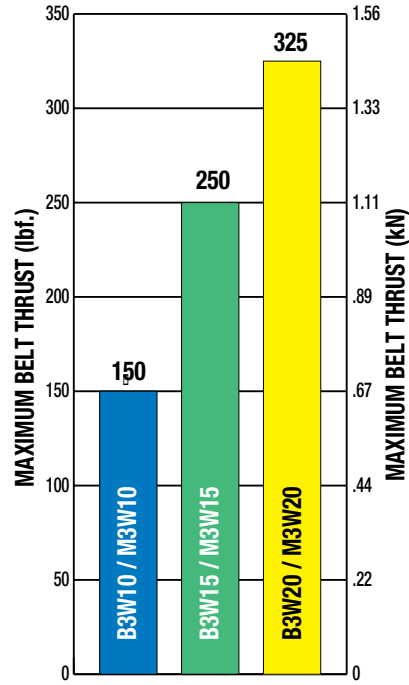

MAXIMUM ACCELERATION AS A FUNCTION OF LOAD WEIGHT

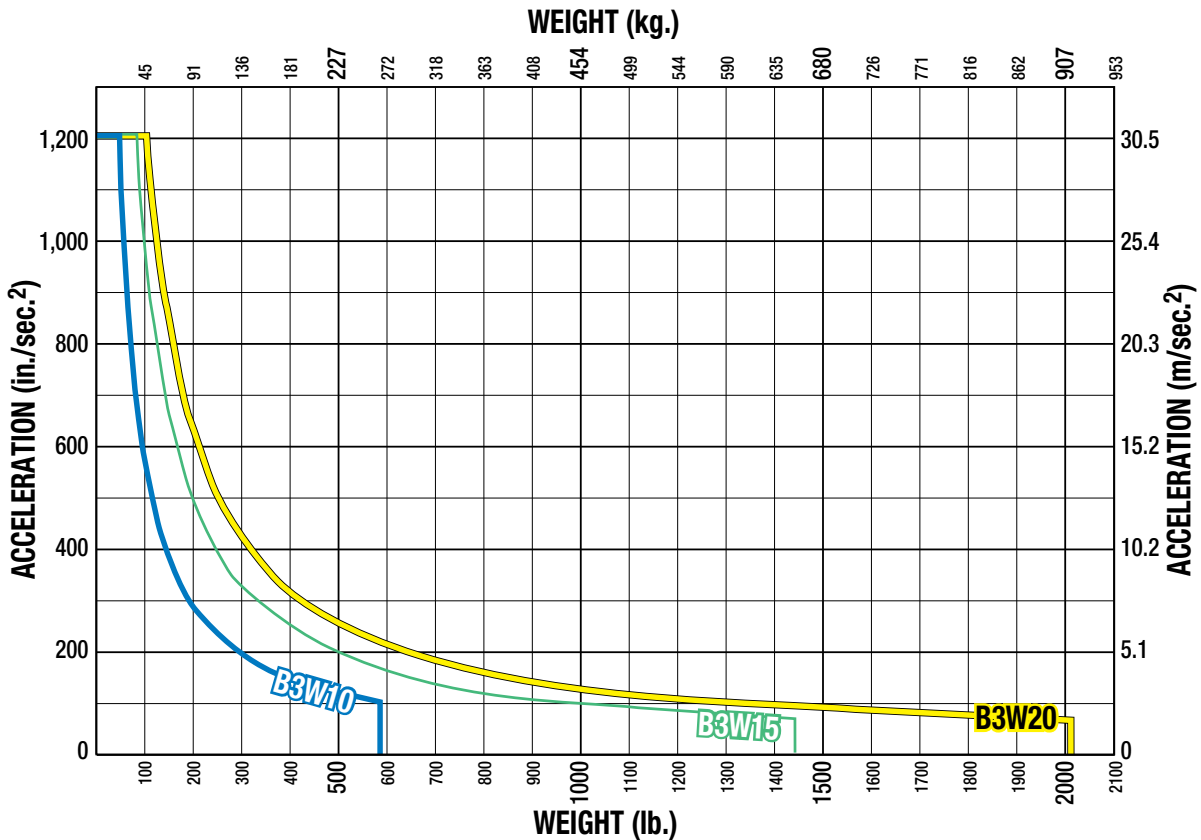

B3W Electric Belt Drive Rodless Actuators

SPECIFICATIONS



		INCH (U.S. Conventional)				METRIC			
		B3W10	B3W15	B3W20		M3W10	M3W15	M3W20	
Max. Stroke	in	207	204	156	mm	5,258	5,182	3,962	
Max. Velocity	in/sec	200	200	200	m/sec	5.08	5.08	5.08	
Max. Acceleration	in/sec ²	1,200	1,200	1,200	m/sec ²	30.48	30.48	30.48	
Max. Input Torque	lb-in	75.2	188.0	285.0	N-m	8.5	21.2	32.2	
Breakaway Torque	Standard (single) Carrier	lb-in	9.38	12.5	28.13	N-m	1.06	1.41	3.18
	Dual 180° or Aux. Carrier	lb-in	11.88	15	31.25	N-m	1.34	1.69	3.53
	Dual 180 & Aux Carrier	lb-in	16.88	25	47.5	N-m	1.91	2.82	5.37
Pulley Pitch Dia.	in	1.003	1.504	1.754	mm	25.48	38.2	44.55	
Stoke per Rev.	in/rev	3.151	4.725	5.51	mm/rev	80.04	120.02	139.95	
Repeatability	in	+/- 0.002	+/- 0.002	+/- 0.002	mm	+/- 0.05	+/- 0.05	+/- 0.05	
Straightness & Flatness ¹	in	0.00067 x L*	0.00067 x L*	0.00067 x L*	mm	0.017 x L*	0.017 x L*	0.017 x L*	
Temp. Range ²	°F	40 - 130	40 - 130	40 - 130	°C	4 - 54	4 - 54	4 - 54	
IP Rating ³	IP	44	44	44	IP	44	44	44	
Weight (zero stroke)	lb	7.54	25.12	35.4	kg	3.42	11.39	16.06	
Weight (per unit of stroke)	lb/in	0.389	0.395	0.716	kg/mm	0.0069	0.0071	0.0128	
Weight of pulley	lb	0.015	0.054	0.1036	kg	0.0068	0.0244	0.047	
Weight of carrier	lb	0.85	1.56	2.14	kg	0.39	0.71	0.97	
Inertia (zero stroke)	lb-in ²	0.2846	1.3917	2.6607	kg-cm ²	0.833	4.073	7.786	
Inertia (per unit of stroke)	lb-in ² /in	0.0016	0.0017	0.0114	kg-cm ² /mm	0.00018	0.0002	0.00131	
Inertia of pulley	lb-in ²	0.0093	0.0748	0.1441	kg-cm ²	0.027	0.219	0.422	
Inertia of carrier	lb-in ²	0.1041	0.5089	0.9728	kg-cm ²	0.305	1.489	2.847	



¹ The listed values relating to straightness/flatness are intended for reference purposes only, and not as an engineering standard of absolute tolerance for a given actuator. Appropriate installation is the single most important factor in reducing such deviation, so good engineering practices such as measurement, mapping, etc. must be employed in applications with stringent straightness/flatness requirements.

² Heat generated by the motor and drive should be taken into consideration as well as linear velocity and work cycle time. For applications that require operation outside of the recommended temperature range, contact the factory.

³ Protected against ingress of solid particles greater than .039 in (1mm) and splashing water.

*"L" is maximum distance between supports - See Support Recommendations graph pg B3_9.

LARGE FRAME MOTORS AND SMALLER SIZE ACTUATORS: Cantilevered motors need to be supported if subjected to continuous rapid reversing duty and/or under dynamic conditions.

NOTE: Zero stroke inertia and weight are for an assembled actuator (including carrier, pulley and belt material) that has zero stroke length. To calculate system inertia use the formula below:

$$\text{System Inertia} = \text{Inertia}_{(\text{zero stroke})} + [\text{Inertia}_{(\text{per unit of stroke})} \times \text{number of units}]$$

(For weight calculation substitute inertia with weight in the above formula)

B3W10 Electric Belt Drive Rodless Actuators

DIMENSIONS Actuator & Options

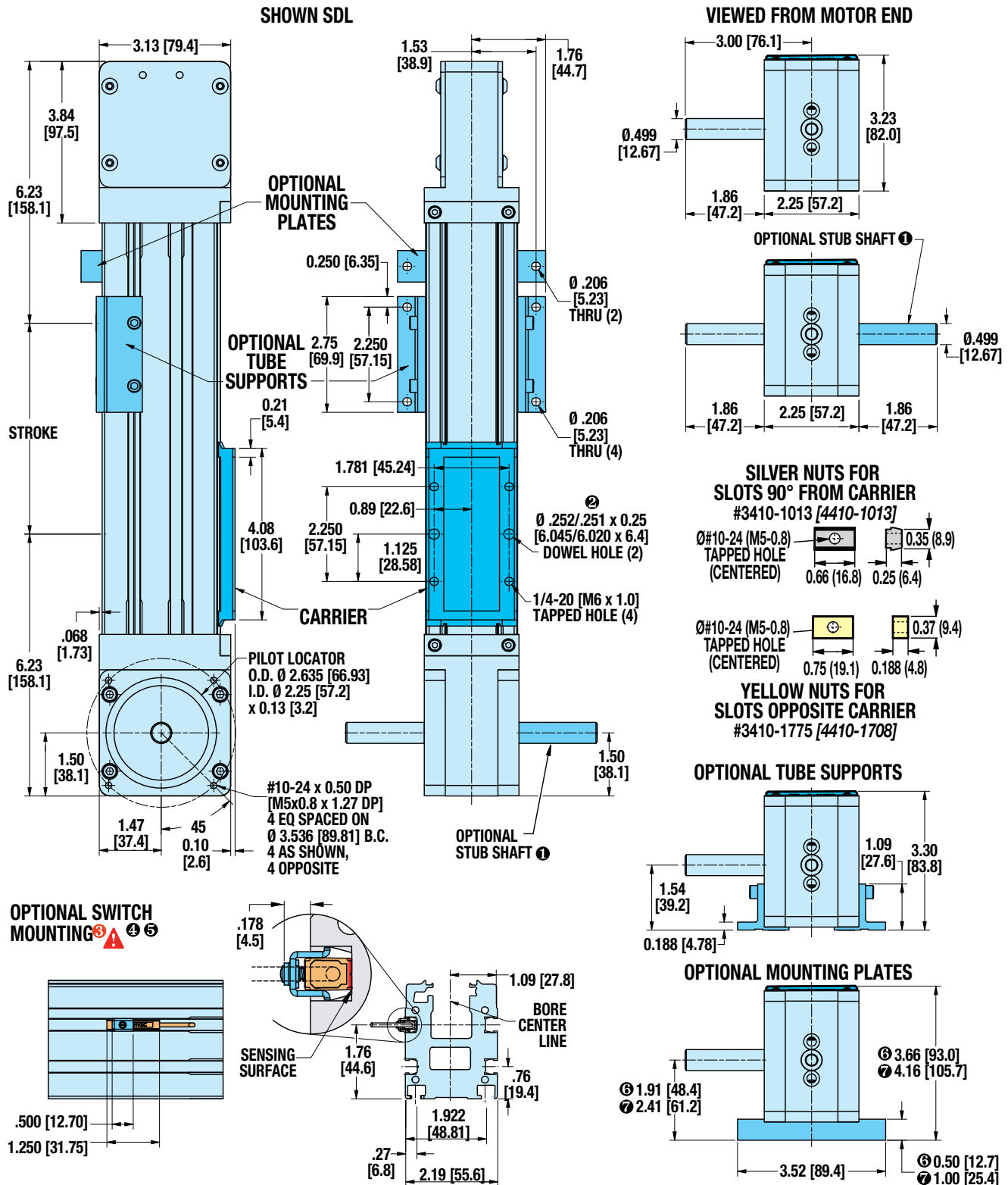

- ① ONE STUB SHAFT IS STANDARD ON ALL B3W ACTUATORS
- ② DOWEL PINS \oplus .003 [.08mm] M
- ⚠ **CAUTION: DO NOT OVERTIGHTEN SWITCH HARDWARE WHEN INSTALLING**
- ④ **NOTE:** The scored face of the switch indicates the sensing surface and must face toward the magnet
- ⑤ **NOTE:** Some actuators require switch mounting on a specific side of the actuator. Call Tolomatic 1-800-328-2174 for details
- ⑥ **WHEN USED WITH 23-FRAME MOTORS**
- ⑦ **WHEN USED WITH 34-FRAME MOTORS**

Unless otherwise noted, all dimensions shown are in inches [Dimensions in brackets are in millimeters]

B3W

B3W10 Electric Belt Drive Rodless Actuators

DIMENSIONS Dual 180° Option

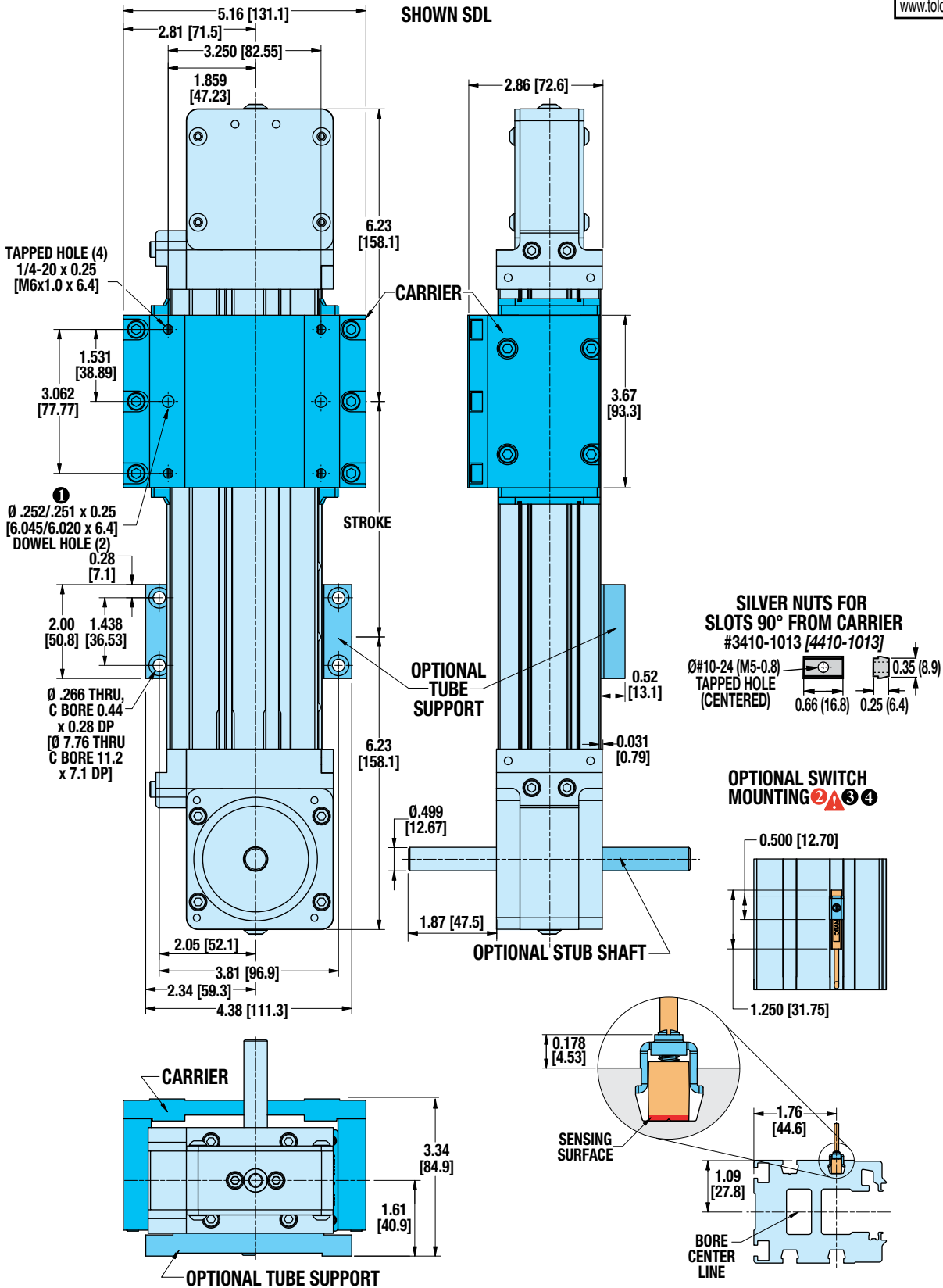

SILVER NUTS FOR SLOTS 90° FROM CARRIER
 #3410-1013 [4410-1013]
 Ø#10-24 (M5-0.8) TAPPED HOLE (CENTERED)
 0.66 [16.8] 0.25 [6.4] 0.35 [8.9]

OPTIONAL SWITCH MOUNTING ② ③ ④

- ① DOWEL PINS ⊕ .003 (.08mm) Ⓜ
- ② **CAUTION: DO NOT OVERTIGHTEN SWITCH HARDWARE WHEN INSTALLING**
- ③ **NOTE:** The scored face of the switch indicates the sensing surface and must face toward the magnet
- ④ **NOTE:** Some actuators require switch mounting on a specific side of the actuator. Call Tolomatic 1-800-328-2174 for details

B3S

B3W

B3W15 Electric Belt Drive Rodless Actuators

DIMENSIONS Dual 180° Option

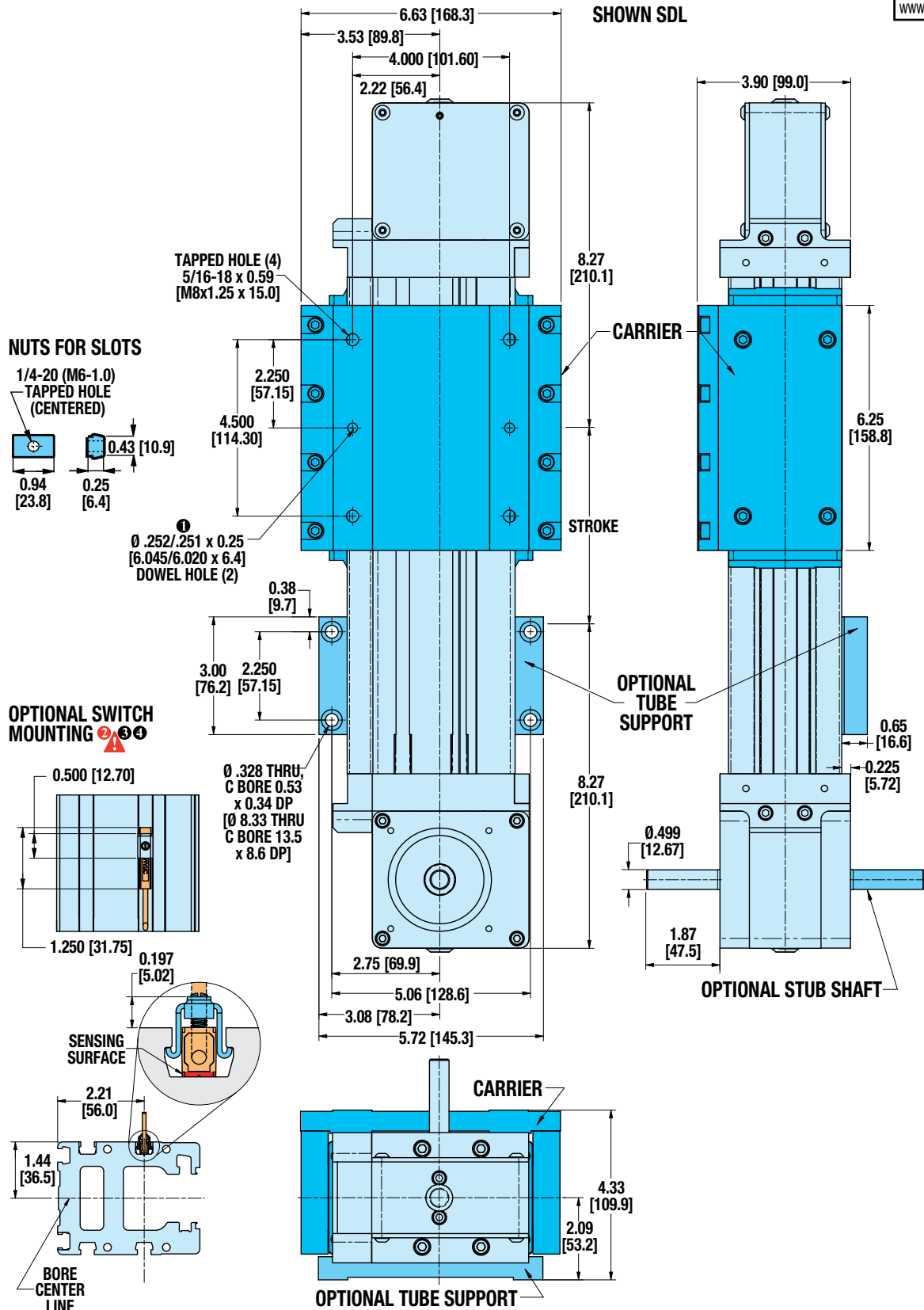

① DOWEL PINS $\pm .003$ (.08mm) (M)

② **CAUTION: DO NOT OVERTIGHTEN SWITCH HARDWARE WHEN INSTALLING**

③ NOTE: The scored face of the switch indicates the sensing surface and must face toward the magnet

④ NOTE: Some actuators require switch mounting on a specific side of the actuator. Call Tolomatic 1-800-328-2174 for details

B3S

B3W

B3W20 Electric Belt Drive Rodless Actuators

DIMENSIONS Actuator & Options

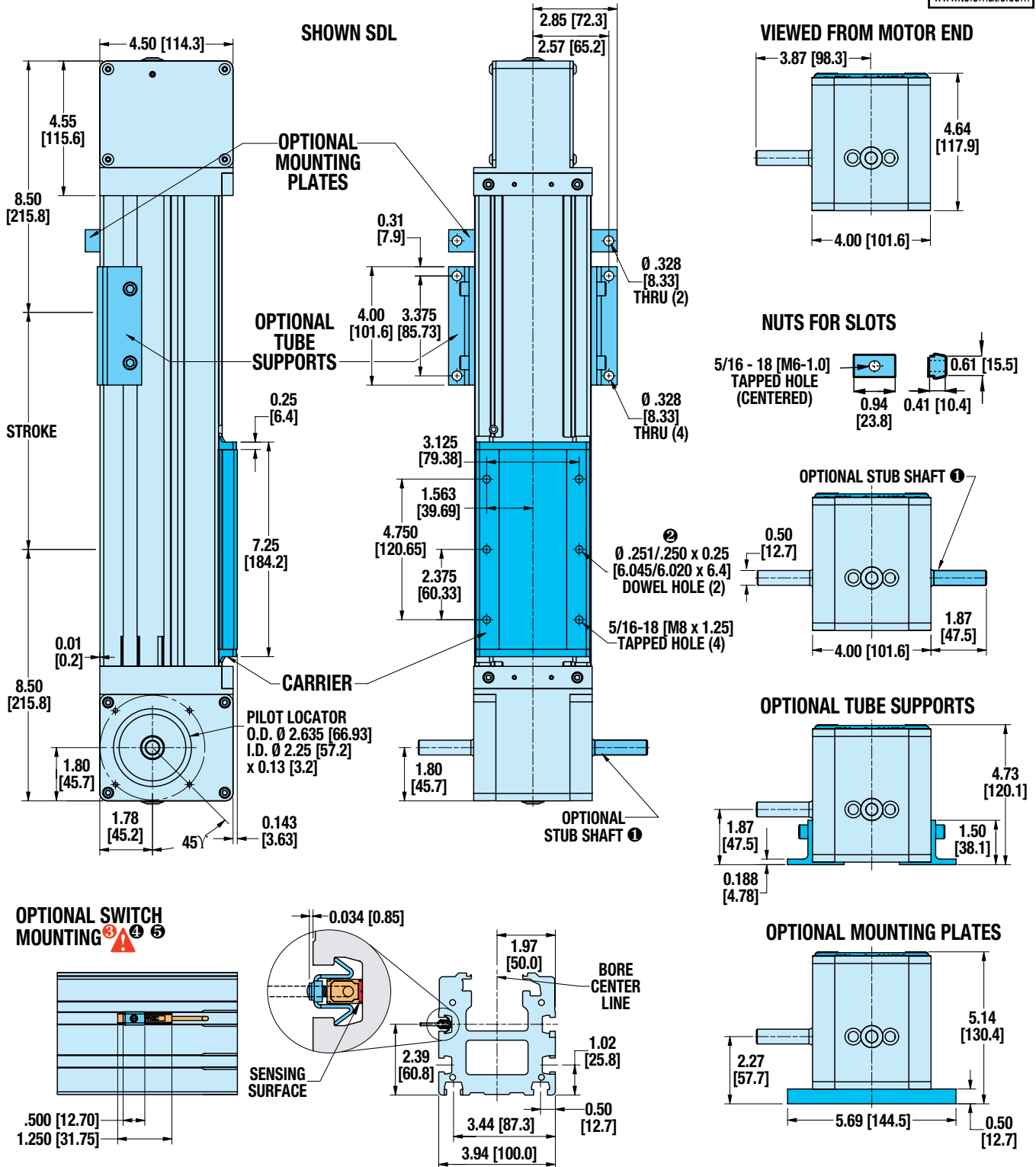

① ONE STUB SHAFT IS STANDARD ON ALL B3W ACTUATORS

② DOWEL PINS $\oplus .003 (.08\text{mm}) \text{M}$

⚠ **CAUTION: DO NOT OVERTIGHTEN SWITCH HARDWARE WHEN INSTALLING**

④ NOTE: The scored face of the switch indicates the sensing surface and must face toward the magnet

⑤ NOTE: Some actuators require switch mounting on a specific side of the actuator. Call Tolomatic 1-800-328-2174 for details

Unless otherwise noted, all dimensions shown are in inches [Dimensions in brackets are in millimeters]

B3W20 Electric Belt Drive Rodless Actuators

DIMENSIONS Dual 180° Option

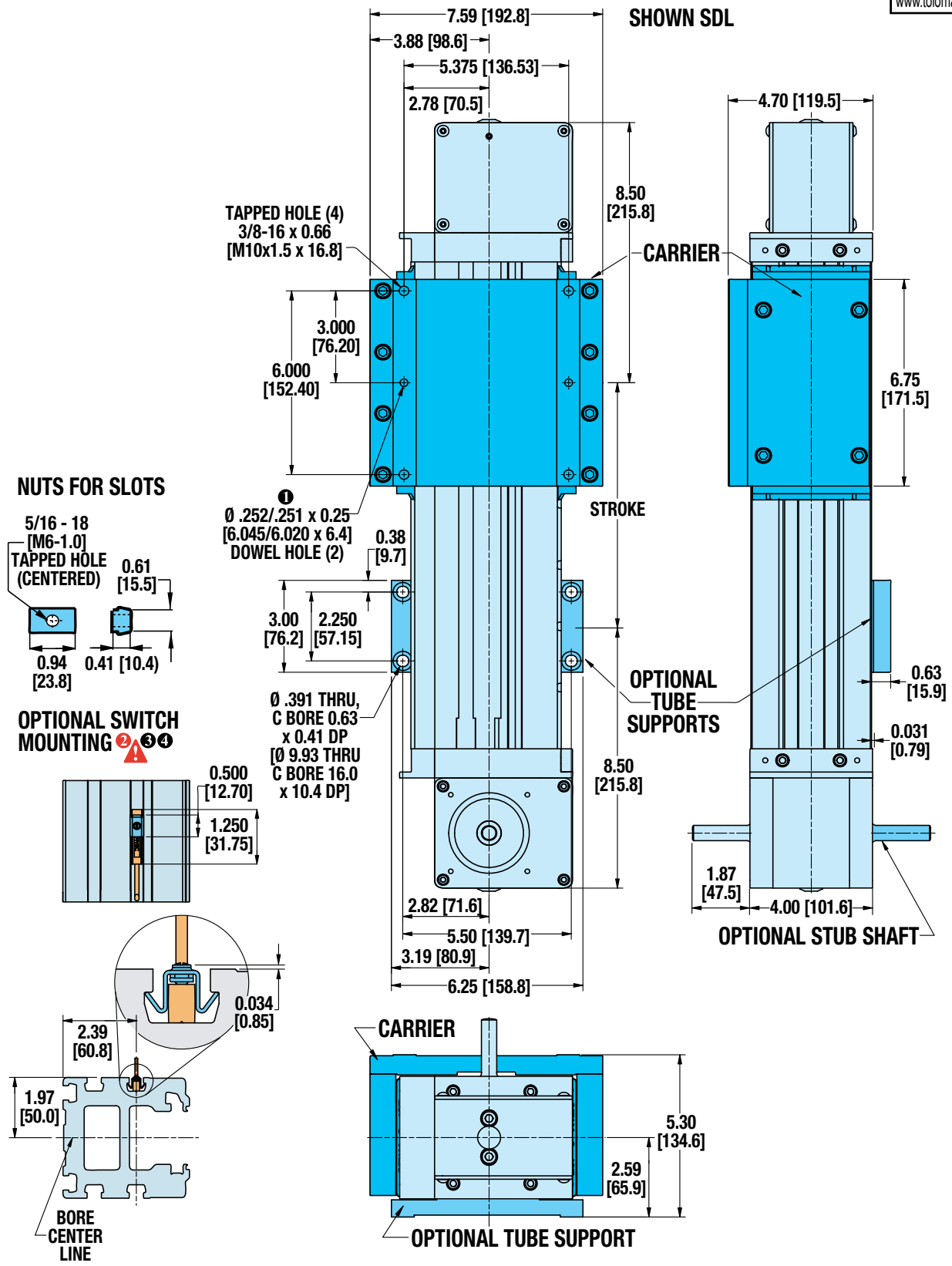

① DOWEL PINS $\pm .003 (.08\text{mm})$ M

② **CAUTION: DO NOT OVERTIGHTEN SWITCH HARDWARE WHEN INSTALLING**

③ **NOTE:** The scored face of the switch indicates the sensing surface and must face toward the magnet

④ **NOTE:** Some actuators require switch mounting on a specific side of the actuator. Call Tolomatic 1-800-328-2174 for details

B3S

B3W

B3W Electric Belt Drive Rodless Actuators

MOTOR MOUNTING

B3W DIRECT DRIVE MOTOR MOUNTING

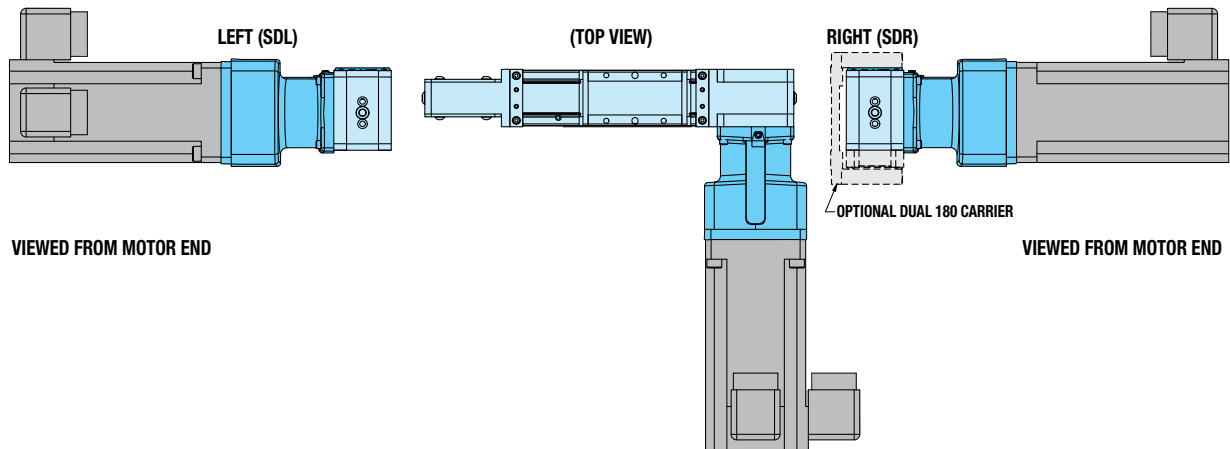

B3W(D) REDUCTION DRIVE MOTOR MOUNTING

STANDARD CARRIER

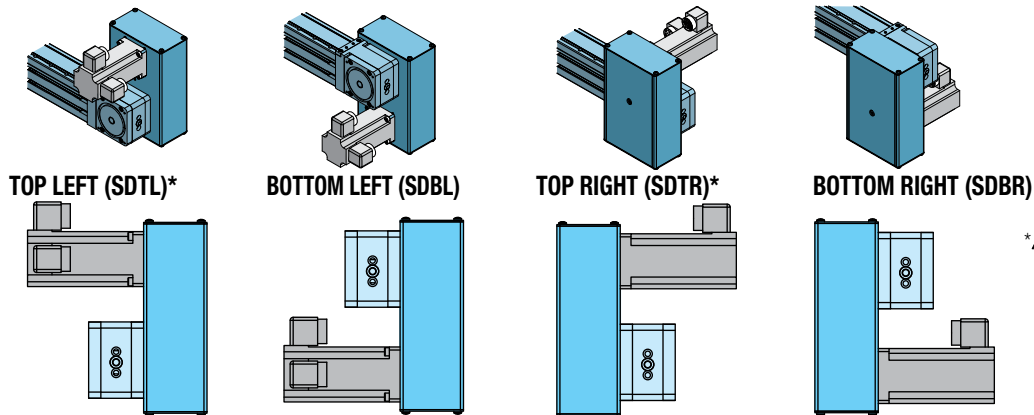

*▲ NOTE: SDTL & SDTR are generally not recommended because the load may interfere with the motor. Stops or spacers may be required.

DUAL 180° CARRIER

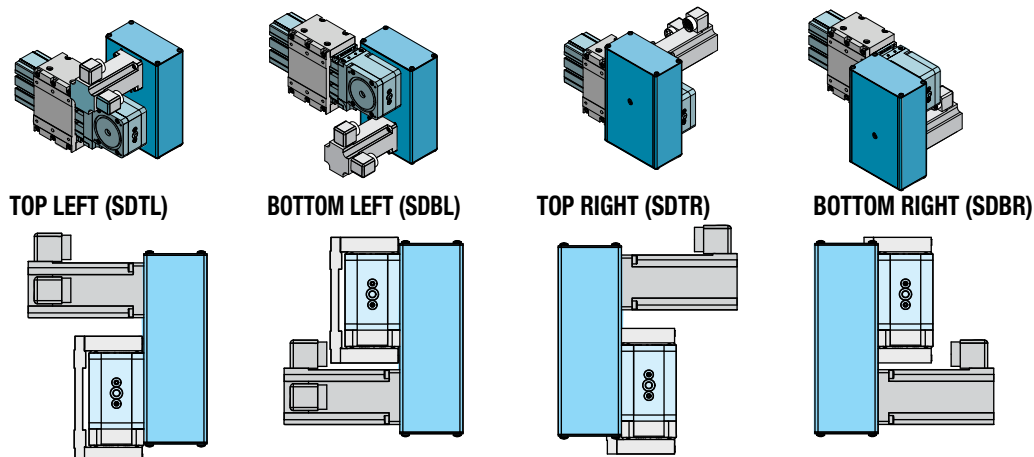

B3S

B3W

B3S & B3W Electric Rodless Actuators

SWITCHES

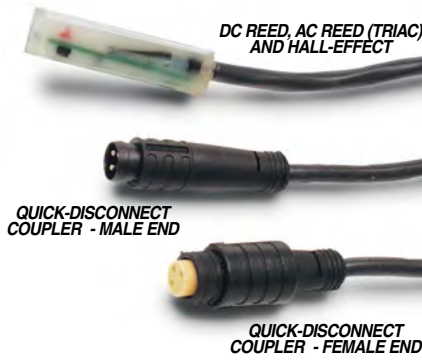

There are 10 sensing choices: DC reed, form A (open) or form C (open or closed); AC reed (Triac, open); Hall-effect, sourcing, PNP (open); Hall-effect, sinking, NPN (open); each with either flying leads or QD (quick disconnect). Commonly used to send analog signals to PLC (programmable logic controllers), TLL, CMOS circuit or other controller device. These switches are activated by the actuator's magnet.

Switches contain reverse polarity protection. QD cables are shielded; shield should be terminated at flying lead end.

If necessary to remove factory installed switches, be sure to reinstall on the same side of actuator with scored face of switch toward internal magnet.

SPECIFICATIONS

ORDER CODE	REED DC				REED AC		HALL-EFFECT DC			
	R T	R M	B T	B M	C T	C M	T T	T M	K T	K M
PART NUMBER	3600-9082	3600-9083	3600-9084	3600-9085	3600-9086	3600-9087	3600-9088	3600-9089	3600-9090	3600-9091
LEAD	5m	QD*	5m	QD*	5m	QD*	5m	QD*	5m	QD*
CABLE SHIELDING	Unshielded	Shielded†	Unshielded	Shielded†	Unshielded	Shielded†	Unshielded	Shielded†	Unshielded	Shielded†
SWITCHING LOGIC	"A" Normally Open		"C" Normally Open or Closed		Triac Normally Open		PNP (Sourcing) Normally Open		NPN (Sinking) Normally Open	
MECHANICAL CONTACTS	Single-Pole Single-Throw		Single-Pole Double-Throw		Single-Pole Single-Throw		NO, These Are Solid State Components			
COIL DIRECT	Yes		Yes		Yes		—			
POWER LED	None	None		None		None	None		None	
SIGNAL LED	Red	Red		Red		Red	Red		Red	
OPERATING VOLTAGE	200 Vdc max.		120 Vdc max.		120 Vac max.		5 - 25 Vdc			
OUTPUT RATING	—		—		—		25 Vdc, 200mA dc			
OPERATING TIME	0.6 msec max. (including bounce)		0.7 msec max. (including bounce)		—		< 10 micro sec.			
OPERATING TEMPERATURE	-40°F [-40°C] to 158°F [70°C]						0°F [-18°C] to 150°F [66°C]			
RELEASE TIME	1.0 msec. max.		—		—		—			
ON TRIP POINT	—		—		—		150 Gauss maximum			
OFF TRIP POINT	—		—		—		40 Gauss minimum			
**POWER RATING (WATTS)	10.0 §		3.0 §§		10.0		5.0			
VOLTAGE DROP	2.6 V typical at 100 mA		NA		—		—			
RESISTANCE	0.1 Ω Initial (Max.)		—		—		—			
CURRENT CONSUMPTION	—		—		1 Amp at 86°F [30°C] 0.5 Amp at 140°F [60°C]		200 mA at 25 Vdc			
FREQUENCY	—		—		47 - 63 Hz		—			
CABLE MIN. BEND RADIUS	STATIC		0.630" [16mm]							
	DYNAMIC		Not Recommended							

CAUTION: DO NOT OVER TIGHTEN SWITCH HARDWARE WHEN INSTALLING!

**** WARNING:** Do not exceed power rating (Watt = Voltage X Amperage). Permanent damage to sensor will occur.

*QD = Quick Disconnect; Male coupler is located 6" [152mm] from sensor, Female coupler to flying lead (part #2503-1025) distance is 197" [5m] also see Cable Shielding specification above

REPLACEMENT OF QD SWITCHES MANUFACTURED BEFORE JULY 1, 1997: It will be necessary to replace or rewire the female end coupler.



Reed Switch Life Expectancy: Up to 200,000,000 cycles (depending on load current, duty cycle and environmental conditions)

†Shielded from the female quick disconnect coupler to the flying leads. Shield should be terminated at flying lead end.

§ Maximum current 500mA (not to exceed 10VA) Refer to Temperature vs. Current graph and Voltage Derating graph

§§ Maximum current 250mA (not to exceed 3VA) Refer to Temperature vs. Current graph and Voltage Derating graph

B3S & B3W Electric Rodless Actuators

SWITCH PERFORMANCE

TEMP. vs CURRENT, DC REED

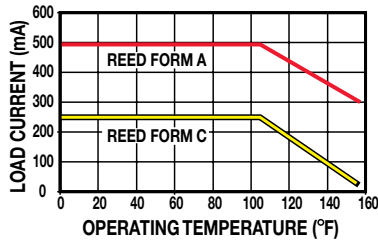

TEMP. vs CURRENT, AC REED

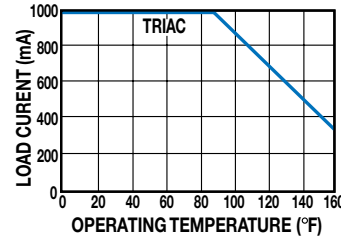

VOLTAGE DERATING, DC REED

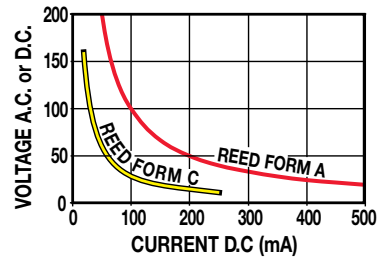

WIRING DIAGRAMS

RT & **R**M DC REED, FORM A

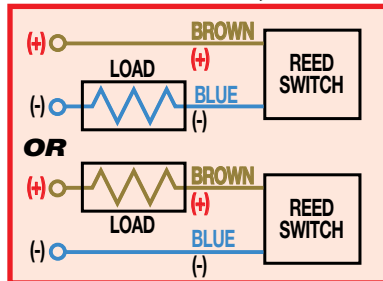

CT & **C**M AC REED, TRIAC

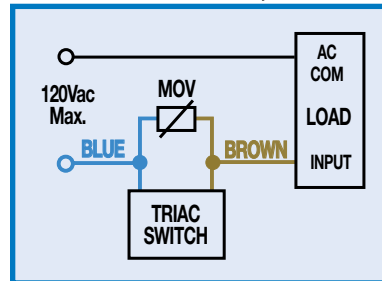

BT & **B**M DC REED, FORM C

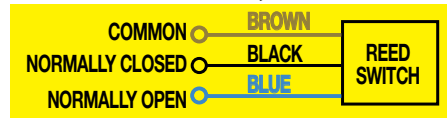

TT & **T**M HALL-EFFECT, SOURCING, PNP

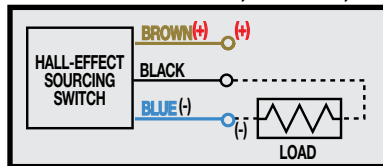

KT & **K**M HALL-EFFECT, SINKING, NPN

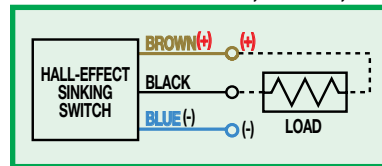

INSTALLATION INFORMATION



! THE NOTCHED FACE OF THE SWITCH INDICATES THE SENSING SURFACE AND MUST FACE TOWARD THE MAGNET.



! THE NOTCHED GROOVE IN THE ACTUATOR INDICATES THE GROOVE TO INSTALL THE SWITCH. CONTACT TOLOMATIC IF SWITCHES ARE REQUIRED ON ANOTHER SIDE OF ACTUATOR.

B3S

B3W

COMPILE APPLICATION REQUIREMENTS

APPLICATION DATA WORKSHEET

Fill in known data. Not all information is required for all applications

ORIENTATION

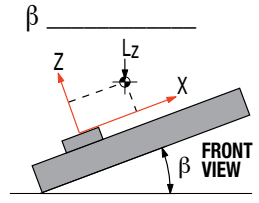
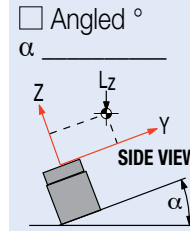
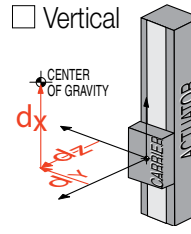
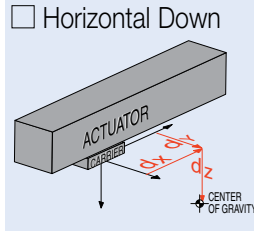
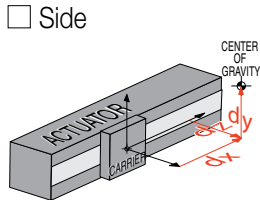
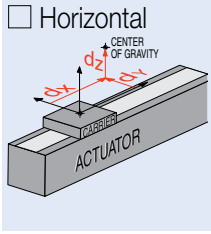

Load attached to carrier OR Load supported by other mechanism

DISTANCE FROM CENTER OF CARRIER TO LOAD CENTER OF GRAVITY

d_x _____
 d_y _____
 d_z _____

inch (U.S. Standard) millimeter (Metric)

STROKE LENGTH

inch (S I) (U.S. Standard) millimeters (Metric)

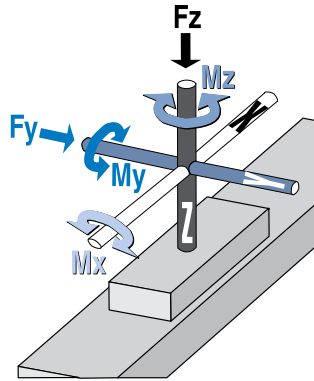

BENDING MOMENTS APPLIED TO CARRIER

M_x _____
 M_y _____
 M_z _____

in.-lbs. (U.S. Standard) N-m (Metric)

PRECISION

Repeatability _____
 inch millimeters

OPERATING ENVIRONMENT

Temperature, Contamination, etc.

NOTE: If load or force on carrier changes during cycle use the highest numbers for calculations

LOAD

lb. (U.S. Standard) kg. (Metric)

THRUST REQUIRED

F_z _____
 F_y _____

lbf. (U.S. Standard) N (Metric)

MOTION PROFILE

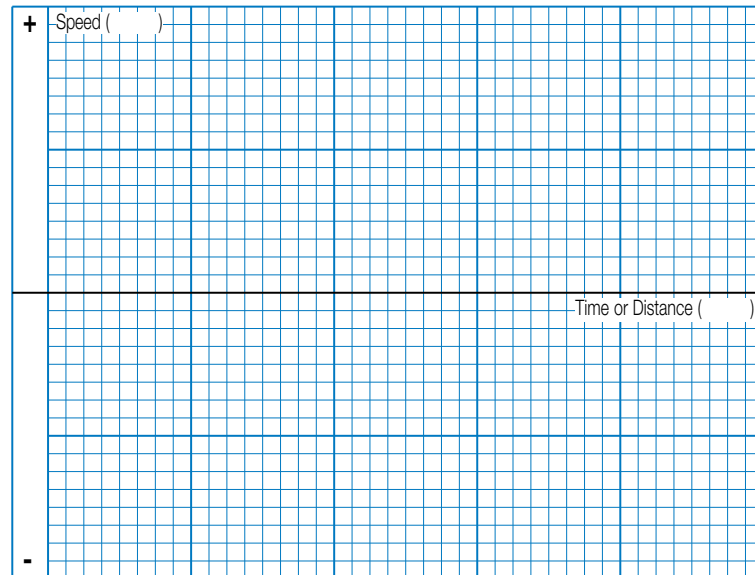

Graph your most demanding cycle, including accel/decel, velocity and dwell times. You may also want to indicate load variations and I/O changes during the cycle. Label axes with proper scale and units.

MOVE PROFILE

Move Distance _____
 inch millimeters

Dwell Time After Move _____

Max. Speed _____
 in/sec mm/sec

MOVE TIME

_____ sec

NO. OF CYCLES

_____ per minute per hour

CONTACT INFORMATION

Name, Phone, Email _____
 Co. Name, Etc. _____



USE THE TOLOMATIC SIZING AND SELECTION SOFTWARE AVAILABLE ON-LINE AT www.tolomatic.com OR... CALL TOLOMATIC 1-800-328-2174 with the above information. We will provide any assistance needed to determine the proper MX actuator for the job.

FAX 1-763-478-8080

SELECTION GUIDELINES

The process of selecting a load bearing actuator for a given application can be complex. It is highly recommended that you contact Tolomatic or a Tolomatic Distributor for assistance in selecting the best actuator for your application. The following overview of the selection guidelines are for educational purposes only.

1 CHOOSE ACTUATOR SIZE

Choose an actuator that has the (A) thrust, (B) speed and (C) moment load capacity to move the load. **A.** Max Thrust: B3S see page B3_11; B3W see page B3_25

B. Max. Speed: B3S see critical speed graphs page B3_13 to B3_15; All B3W sizes = 200 in/sec (5m/sec).

C. Moment & Load B3S & B3W see page B3_8

2 COMPARE LOAD TO MAXIMUM LOAD CAPACITIES

Calculate the application load (combination of load mass and forces applied to the carrier) and application bending moments (sum of all moments M_x , M_y , and M_z applied to the carrier). Be sure to evaluate the magnitude of dynamic inertia moments. When a rigidly attached load mass is accelerated or decelerated, its inertia induces bending moments on the carrier. Careful attention to how the load is decelerated at the end of the stroke is required for extended actuator performance and ap-

plication safety. If either load or any of your moments exceed figures indicated in the Moment and Load Capacity table (page B3_8) for the actuator consider:

- 1) Higher capacity bearing style
- 2) A larger actuator size
- 3) Auxiliary carrier
- 4) External guide system

3 CALCULATE LOAD FACTOR LF

For loads with a center of gravity offset from the carrier account for both applied (static) and dynamic loads. The load factor (LF) must not exceed the value of 1.5.

$$LF = \frac{M_x}{M_{x_{max}}} + \frac{M_y}{M_{y_{max}}} + \frac{M_z}{M_{z_{max}}} + \frac{F_y}{F_{y_{max}}} + \frac{F_z}{F_{z_{max}}} \leq 1.5$$

If LF does exceed the value of 1.5, consider the four choices listed in step #2.

4 ESTABLISH YOUR MOTION PROFILE AND CALCULATE ACCELERATION RATE

Using the application stroke length and maximum carrier velocity (or time to complete the linear motion), establish the motion profile. Select either triangular (accel-decel) or trapezoidal (accel-constant speed-decel) profile. Now calculate the maximum acceleration and deceleration rates of the move.

For the B3S Acceleration/deceleration should not exceed critical speed (page B3_13) for the screw/nut combination chosen. **For the B3W** acceleration/deceleration should not exceed 1200 in/sec² (30.48 m/sec²). Also, do not exceed safe rates of dynamic inertia moments determined in step #3.

5 SELECT THE LEAD SCREW (B3S ONLY)

Based on the application requirements for accuracy, backlash, quiet operation, life, etc. select the appropriate lead screw type (Acme screw with a solid nut or ball screw with a standard or anti-backlash nut) and the pitch (lead). For additional information on screw selection, consult "Which Screw? Picking the Right Technology" (#9900-4644) available at www.tolomatic.com.

6 SELECT MOTOR (GEARHEAD IF NECESSARY) AND DRIVE

To help select a motor and drive, use the sizing equations located in the Engineering Resources section [ENGR_] of the Tolomatic Electric Products Catalog (#3600-4609) to calculate the application thrust and torque requirements. Refer to Motor sections to determine the motor and drive.

7 DETERMINE TUBE SUPPORT/ MOUNTING PLATE/ T-NUT REQUIREMENTS

- Consult the Tube Support Requirements graph for the model selected (page B3_9)
- Cross reference the application load and maximum distance between supports
- Select the appropriate number of tube supports, T-nuts or mounting plates and requirements for motor and adapter clearance.

8 CONSIDER OPTIONS

- Choose metric or inch (US Conventional) load mounting. (When ordering use **SK** for inch)
- Switches - Reed, Solid State PNP or NPN, all available normally open or normally closed

Use the Tolomatic Sizing & Selection Software or call Tolomatic at 1-800-328-2174



B3S Electric Screw Drive Rodless Actuators



ORDERING

BASE MODEL

B3SD 20 BNL02 SK36 LMI

OPTIONS

DC18 TS2 BM2 TN8

MODEL TYPE

B3S B3S Inch (US Conventional) Screw Drive
B3SD B3S Inch (US Conventional) Screw Drive with Dual 180° Carrier
M3S B3S Metric Screw Drive
M3SD B3S Metric Screw Drive with Dual 180° Carrier

TUBE BORE DIAMETER

10 1-inch (25 mm) bore
15 1½-inch (40 mm) bore
20 2-inch (50 mm) bore

NUT/SCREW CONFIGURATION

Inch (US Conventional) MODELS

SOLID NUT / PITCH (turn/in)	SERIES
SN01	B3S(D)10, 15, 20
SN02	B3S(D)10, 15, 20
SNA02	B3S(D)10, 15
SN05	B3S(D)10

BALL NUT / PITCH (turn/in)	SERIES
BN02	B3S(D)15, 20
BNL02	B3S(D)15, 20
BN05	B3S(D)15, 20
BNL05	B3S(D)15, 20
BN08	B3S(D)10
BNL08	B3S(D)10

METRIC MODELS

SOLID NUT / LEAD (mm/turn)	SERIES
SN12	M3S(D)10, 15, 20
SN25	M3S(D)10, 15, 20

BALL NUT / LEAD (mm/turn)	SERIES
BN08	M3S(D)10
BNL08	M3S(D)10

BALL NUT / LEAD (mm/turn)	SERIES
BN05	M3S(D)15, 20
BNL05	M3S(D)15, 20

STROKE LENGTH

SK Stroke, then enter desired stroke length in decimal inches

MOTOR MOUNTING / REDUCTIONS

(must choose one)

LMI In-Line mounting
LME23 Ext. shaft for RP & 23 frame motor
LME34 Ext. shaft for RP & 34 frame motor
LME40 Ext. shaft for RP & 40 frame motor
***LMX** Extended shaft - old style (see note)
**For replacement actuators with extended motor shafts purchased prior to 6/24/02, use the LMX configuration code.*

⚠ A motor size and code must be selected when specifying a reverse-parallel mounting configuration. Reference the MRV or MRS section for the motor types and selections.

RPL1 1:1 Reverse-Parallel mount left
RPR1 1:1 Reverse-Parallel mount right
RPB1 1:1 Reverse-Parallel mount bottom
RPT1 1:1 Reverse-Parallel mount top
RPL2 2:1 Reverse-Parallel mount left
RPR2 2:1 Reverse-Parallel mount right
RPB2 2:1 Reverse-Parallel mount bottom
RPT2 2:1 Reverse-Parallel mount top

Your Motor Here



CUSTOM MOTOR MOUNTS. 5 DAYS.

Tolomatic electric actuators are compatible with over 60 motor manufacturers and hundreds of motor models.

AUXILIARY CARRIER

DC_ Auxiliary Carrier, then center-to-center spacing desired in decimal inches. (Center-to-Center spacing will add to overall dead length and will not subtract from the stroke length)

SUPPORTS AND MOUNTING PLATES

(both may be selected)

TS_ Tube Supports plus quantity desired
****MP_** Mounting Plates plus quantity desired
***Mounting plates are not available on B3SD Dual 180° models.*

SWITCHES^s

(Quantity desired follows product code)

RM_ Reed Switch (Form A) with 5-meter lead/QD (Quick-disconnect)
RT_ Reed Switch (Form A) with 5-m lead
BM_ Reed Switch (Form C) with 5-meter lead/QD
BT_ Reed Switch (Form C) with 5-m lead
KM_ Hall-effect Sinking Switch with 5-meter lead/QD
KT_ Hall-effect Sinking Switch w/ 5-m lead
TM_ Hall-effect Sourcing Switch with 5-meter lead/QD
TT_ Hall-effect Sourcing Switch with 5-meter lead
CM_ TRIAC Switch with 5-meter lead/QD
CT_ TRIAC Switch with 5-meter lead

T-NUTS

TN_ Additional T-Nuts and quantity

⚠ Not all codes listed are compatible with all options.

Use Tolomatic Sizing Software to determine available options and accessories based on your application requirements.

FIELD RETROFIT KITS

ITEM	B3S10	B3S15	B3S20	M3S10	M3S15	M3S20
Tube Supports	3410-9006	3415-9006	3420-9006	4410-9006	4415-9006	4420-9006
Tube Supports (B3SD Dual 180° models)	3410-9026	3415-9026	3420-9026	4410-9026	4415-9026	4420-9026
1/2" Mounting Plates	3410-9142	3415-9056	3420-9056	4410-9030	4415-9030	4420-9030
1" Mounting Plates	3410-9057	3415-9057	—	4410-9031	4415-9031	—

B3W Electric Belt Drive Rodless Actuators



ORDERING

BASE MODEL

B3WD 20 BWS40 SK56 SDTR

OPTIONS

DC18 TS2 BM2 TN16

MODEL TYPE

B3W B3W Series Belt Drive
B3WD B3W Series Belt Drive with Dual 180° Carrier
M3W* B3W Series Metric Belt Drive
M3WD* B3W Series Metric Belt Drive with Dual 180° Carrier

**The M3W metric version provides metric tapped holes for mounting of the load to the carrier and of the actuator to mounting surfaces*

TUBE BORE DIAMETER

10 1-inch (25 mm) bore
15 1 1/2-inch (40 mm) bore
20 2-inch (50 mm) bore

BELT MATERIAL AND WIDTH

BWS18 18mm Polyurethane Steel belt (B3W10)
BWS30 30mm Polyurethane Steel belt (B3W15)
BWS40 40mm Polyurethane Steel belt (B3W20)

STROKE LENGTH

SK _____ Stroke, enter desired stroke length in decimal inches

MOTOR MOUNTING / REDUCTIONS

(must choose one)

SDL, SDLB* Direct Drive on left
SDR, SDRB* Direct Drive on right

▲ A motor size and code must be selected when specifying a 3:1 reduction. Reference the ordering pages* for the motor types and selections.

SDTL, SDTLB* 3:1 Reduction on top left
SDTR, SDTRB* 3:1 Reduction on top right
SDBL, SDBLB* 3:1 Reduction on bottom left
SDBR, SDBRB* 3:1 Reduction on bottom right
** For Dual Stub Shaft option*

AUXILIARY CARRIER

DC _____ Auxiliary Carrier, enter center-to-center spacing desired in decimal inches.

▲ Center-to-Center spacing will add to overall dead length and will not subtract from the stroke length

Your Motor Here

CUSTOM MOTOR MOUNTS. 5 DAYS.

Tolomatic electric actuators are compatible with over 60 motor manufacturers and hundreds of motor models.

SUPPORTS AND MOUNTING PLATES

(both may be selected)

TS _ Tube Supports, enter quantity desired
MP _ Mounting Plates, enter quantity desired

SWITCHES

CODE	TYPE	QUICK-DISCONNECT	LEAD LENGTH	QUANTITY
RM	Form A	QD	5 meters	After code enter quantity desired
RT		no		
BM		QD		
BT	Form C	no		
KM		QD		
KT	Sinking	no		
TM	Sourcing	QD		
TT		no		
CM	TRIAC	QD		
CT		no		

T-NUTS

TN _ Additional T-Nuts, enter quantity

▲ Not all codes listed are compatible with all options.

Use Tolomatic Sizing Software to determine available options and accessories based on your application requirements.

FIELD RETROFIT KITS

ITEM	B3W10	B3W15	B3W20	M3W10	M3W15	M3W20
Tube Supports	3410-9006	3415-9006	3420-9006	4410-9006	4415-9006	4420-9006
Tube Supports (B3WD Dual 180° models)	3410-9170	3415-9170	3420-9170	4410-9170	4415-9170	4420-9170
1/2" Mounting Plates (MRV 23-frame motors)	3410-9056	3415-9056	—	4410-9030	4415-9030	—
1/2" Mounting Plates (MRV all frame motors)	—	—	3420-9056	—	—	4420-9030
1" Mounting Plates (MRV all frame motors)	3410-9057	—	—	4410-9031	—	—
1" Mounting Plates (MRV 34-frame motors)	—	3415-9057	—	—	4415-9031	—

THE TOLOMATIC DIFFERENCE What you expect from the industry leader:



EXCELLENT CUSTOMER SERVICE & TECHNICAL SUPPORT

Our people make the difference! Expect prompt, courteous replies to all of your application and product questions.



INDUSTRY LEADING DELIVERIES

Tolomatic continues to offer the fastest delivery of standard catalog products. Modified and custom products ship weeks ahead of the competition.

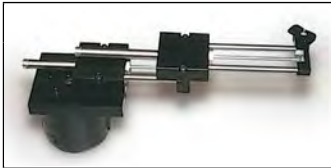

INNOVATIVE PRODUCTS

From standard catalog products... to modified products... to completely unique custom products, Tolomatic designs and builds the best solutions for your challenging applications.

ACTUATOR



ONLINE SIZING & SELECTION SOFTWARE

Online sizing that is easy to use, accurate and always up-to-date. Input your application data and the software will determine a Tolomatic electric actuator to meet your requirements.



3D MODELS & 2D DRAWINGS AVAILABLE ON THE WEB

Easy to access CAD files are available in many popular formats.

ALSO CONSIDER THESE OTHER TOLOMATIC PRODUCTS:

PNEUMATIC PRODUCTS



RODLESS CYLINDERS: Band Cylinders, Cable Cylinders, MAGNETICALLY COUPLED CYLINDERS/SLIDES; GUIDED ROD CYLINDER SLIDES

"FOLDOUT" BROCHURE #9900-9075
PRODUCTS BROCHURE #9900-4028

ELECTRIC PRODUCTS



POWER TRANSMISSION PRODUCTS



GEARBOXES: Float-A-Shaft®, Slide-Rite®; DISC CONE CLUTCH; CALIPER DISC BRAKES

"FOLDOUT" BROCHURE #9900-9076
PRODUCTS BROCHURE #9900-4029

ROD & GUIDED ROD STYLE ACTUATORS, HIGH THRUST ACTUATORS, SCREW & BELT DRIVE RODLESS ACTUATORS, MOTORS, DRIVES AND CONTROLLERS

"FOLDOUT" BROCHURE #9900-9074
PRODUCTS BROCHURE #9900-4016



3800 County Road 116 • Hamel, MN 55340 U.S.A.
Phone: (763) 478-8000 • Fax: (763) 478-8080

Toll-Free: **1-800-328-2174**

Email: help@tolomatic.com • <http://www.tolomatic.com>



All brand and product names are trademarks or registered trademarks of their respective owners. Information in this document is believed accurate at time of printing. However, Tolomatic assumes no responsibility for its use or for any errors that may appear in this document. Tolomatic reserves the right to change the design or operation of the equipment described herein and any associated motion products without notice. Information in this document is subject to change without notice.

Visit www.tolomatic.com for the most up-to-date technical information

