

## SmartActuator Series

# ICR Basic & Plus

INTEGRATED CONTROL ROD-STYLE ACTUATOR

**ENDURANCE TECHNOLOGY<sup>SM</sup>**

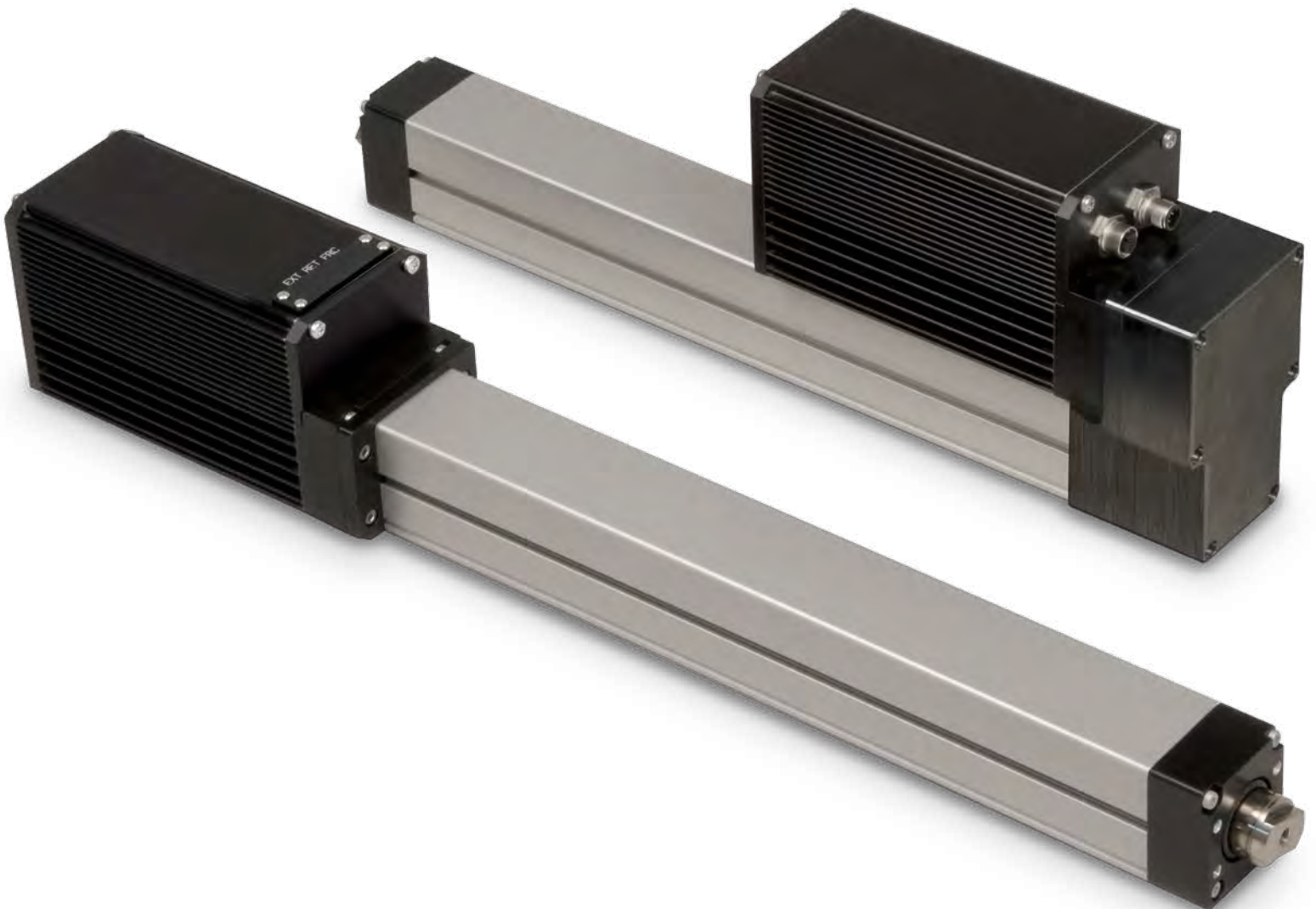

# What is a **SmartActuator**?

The SmartActuator is a controller, drive and motor integrated into one compact, durable, lightweight actuator. Designed for simple extend and retract operation, the ICR Basic can easily be installed and set up by anyone familiar with pneumatic or hydraulic cylinders. For flexibility, the Plus offers indexer programming and network communication capabilities for a wide variety of demanding applications.

Tolomatic has over 50 years of experience manufacturing rodless and rod-style electric and pneumatic actuators. The SmartActuator puts this experience and the intelligence of powerful digital drive technology into one actuator. The result: reliable, affordable power that is remarkably easy-to-use.

## **Basic & Plus Capabilities**

- 100% duty cycle for continuous operation
- 24 Vdc opto-isolated inputs, NPN or PNP
- IP65 option - For protection against water and dust ingress



## **ICR Basic**

The SmartActuator **ICR Basic** features 2-position extend/retract capability, mid-stroke positioning with sensors, and force control.

### **ICR Basic Capabilities**

- 2-position extend / retract
- 2 outputs, 24V line driver; fault, in-position
- 4 inputs, Enable, E-Stop, Fwd., Rev.
- Independent extend/retract speed control
- Mid-stroke positioning with sensors
- Force control/limiting

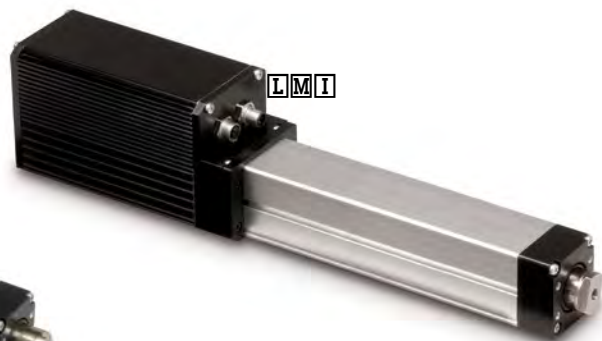

## **ICR Plus**

The **ICR Plus** has all the ICR Basic capabilities and adds: indexing, network communication, stand-alone operation, stepper and analog position modes.

### **Plus Capabilities**

- Indexer programming
- 2 outputs, opto-isolated sinking/sourcing
- 8 inputs
- Stand-alone operation
- Infinite positioning
- Network communication
  - CANopen
  - DeviceNet
  - RS-232 to CANopen
- Stepper mode (Pulse / direction)
- Analog position mode

# Choose the **Smart**Actuator for these advantages:

## vs PNEUMATIC / HYDRAULIC CYLINDERS

- More cost effective to operate
  - Less power consumption
- No costly and messy leaks
- Fewer, cleaner components
  - Eliminates valves, hoses, condensers, mufflers, filters, lubricators, compressors
- Precise control of position, speed, acceleration and force
- Quiet operation
- Accurately positions load at multiple and repeatable locations
- Ability to synchronize motion with other machine operations

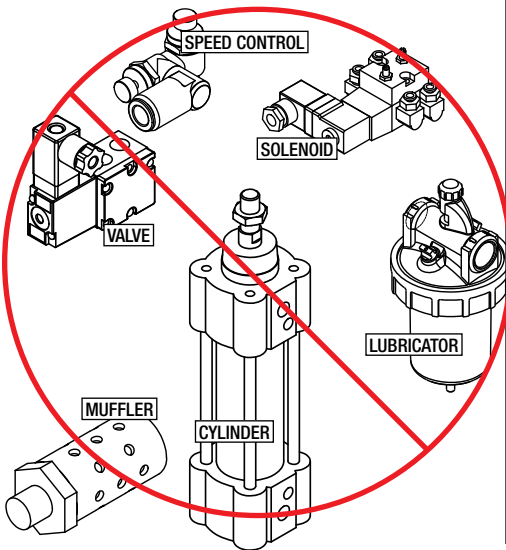

## vs INTEGRATED STEPPER ACTUATOR

- True closed loop control ensures position is actually met
- Servo motors supply 100% duty cycle vs. stepper motors which typically supply less than 50% duty cycle
- Expanded speed / torque capability

**SPEED vs THRUST**  
ICR Motor & Integrated Stepper Motor

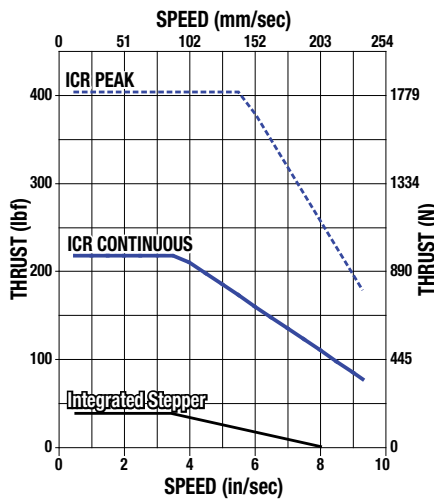

## vs TRADITIONAL ELECTRIC SYSTEMS

- Fewer components to purchase and assemble
  - Eliminates separate actuator, motor, drive, cables, coupler and motor mount
- Eliminates need for additional cabinet space: smaller footprint
- Approximately 1/2 the cost of traditional electric actuator systems
- ICR Basic model does not require a computer or software

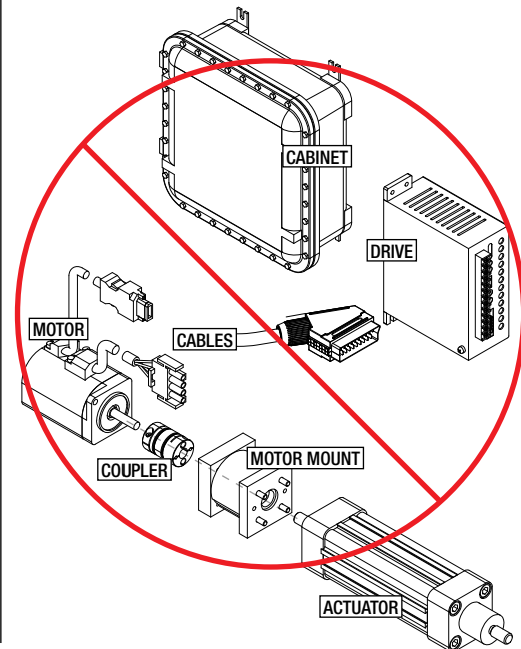

CONTENTS		
What is the SmartActuator?.....2	ICM Integrated Control Motor..... 12	Switches .....24
ICR Basic Introduction .....4	ICR Specifications & Performance.... 13	Service Parts Ordering .....26
ICR Basic Features.....6	ICR Dimensions .....17	Ordering.....27
ICR Plus Introduction.....8	Application Data Worksheet.....22	
ICR Plus Features .....10	Selection Guidelines.....23	

## About the ICR Basic

The ICR Basic is an easy-to-use, all-in-one (control, drive, motor, actuator) electric rod-style actuator designed for industrial applications. The ICR Basic is a perfect pneumatic or hydraulic cylinder replacement for low to medium thrust applications. Easy-to-use setup requires no software, tuning or programming.

### Capabilities

- 2-position extend / retract
- Independent extend/retract speed control
- Mid-stroke positioning with sensors
- Force control/limiting
- 100% duty cycle for continuous operation
- 4 inputs, Enable, E-Stop, Fwd., Rev.
- 2 outputs, 24V line driver; fault, in-position
- 24 Vdc opto-isolated inputs, NPN or PNP
- IP65 option - For protection against water and dust ingress

## ICR Basic Applications

### Press Fitting System

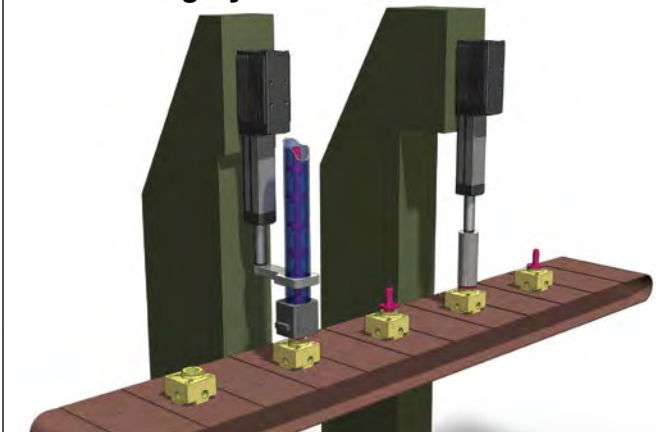

Force control is utilized to limit output force of actuator to press parts together. Similar applications include:

- Parts placement
- Labeling
- Stamping
- Inserting

### Parts Transfer

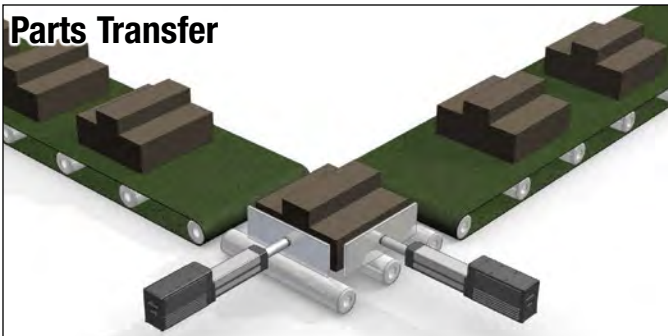

2-position and mid-stroke positioning is used to transfer parts. Examples include:

- Diverting
- Gating
- Sorting
- Rejecting

### Alignment of Work



Force control is utilized to align parts, similar applications include:

- Clamping
- Parts verification
- Labeling
- Guiding

# ICR Basic Modes of Operation

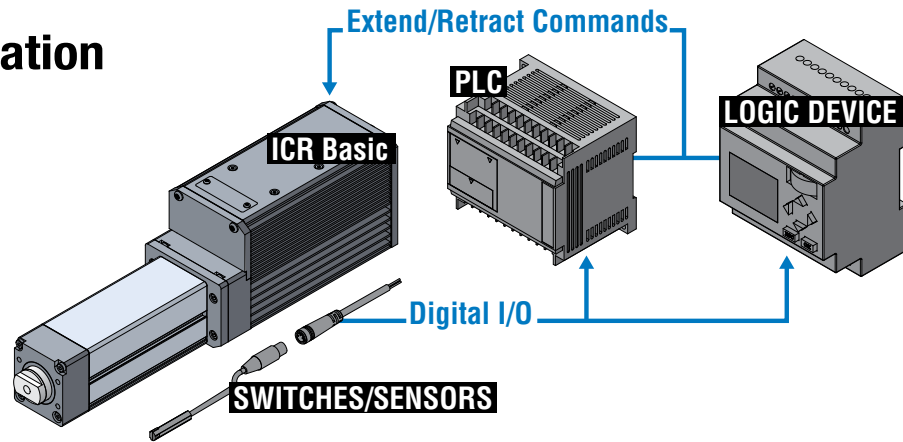

## Easy Setup Procedure:

- 1) Mount SmartActuator
- 2) Wire 24 or 48 Vdc power to SmartActuator
- 3) Wire extend, retract, enable, e-stop inputs & in-position/fault output cables to PLC
- 4) Program your PLC (often using same signals as a pneumatic unit)
- 5) Adjust retract speed and extend speed
- 6) Adjust force

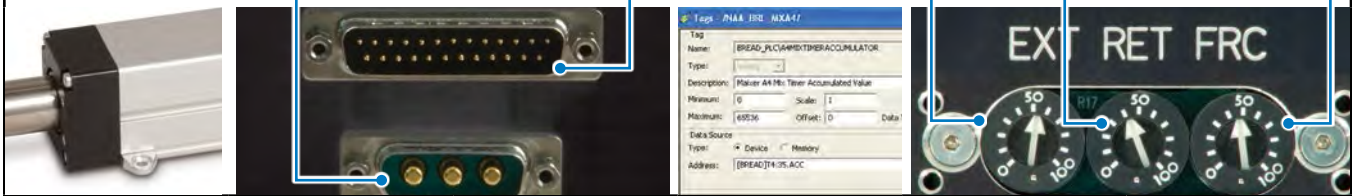

## Easy Operation

**Enable input:** Enables or disables the actuator.

**Extend / retract input:** Extends / retracts the actuator's rod as long as signal is sent or until end of stroke is reached.

**E-Stop input:** Emergency stop, disables actuator.

**Fault output:** Sends signal to logic device for a fault condition.

**In-position output:** Sends signal to logic device indicating actuator is in position and motion is complete.



Speed and force of the ICR Basic are easily adjusted with simple interface controls.

- Speed Control - Independent control of extend and retract speed from 2 to 100% of capable range.
- Force Control - Adjustable from 10 to 100% of maximum force. Once force is reached, the actuator will stop and hold position.

# SmartActuator ICR Basic

## INTEGRATED CONTROL ROD-STYLE ACTUATOR

### ENDURANCE TECHNOLOGY<sup>SM</sup>

Endurance Technology features are designed for maximum durability to provide extended service life. This endurance technology symbol indicates our durability design features.

### MOTOR ORIENTATION

#### YOU CAN CHOOSE

• **LM** In-line option directly couples the driving shaft and is a one-piece housing construction for optimum alignment and support of the motor



• **RP** Reverse-parallel option minimizes the overall length and offers 1:1 or 2:1 belt ratio

### BALL SCREW TECHNOLOGY

- Oversized ball screw selection for extremely long service life
- Lubricated for life of actuator at the factory with the highest quality synthetic grease



### THRUST TUBE

- Hardened nickel plated steel rod ground and polished for greater durability than stainless steel
- Excellent corrosion resistance from many chemicals and resists incidental contact damage

### INTERNAL BUMPER

- Bumper protects the screw and nut assembly from damage at the end of stroke

### THREADED ROD END

- Nickel plated aluminum for corrosion resistance
- Provides a common interface to multiple rod end options

### ROD WIPER

- Prevents contaminants from entering the housing for extended life of the actuator

### BEARING

- Unique nose bearing material allows smooth operation and support of the thrust rod

### ANTI-ROTATE BEARING

- Engineered resin guide bearings provide anti-rotation of the thrust rod
- Supports the thrust tube and nut assembly through entire stroke length

## LIGHTWEIGHT ALUMINUM DESIGN

- Clear anodized extrusion design is optimized for rigidity and strength
- External switch channels and mounting channels along full length on both sides allow easy placement of position indicating switches and tube clamps/mounting plates

## ICR BASIC - EXCLUSIVE FEATURE

### DIGITAL DRIVE

- Operated via digital I/O to extend/retract
- No software, programming or tuning

### DIGITAL ENCODER

- For closed loop control

### CONNECTORS

- Standard
- Optional IP65



## ALUMINUM MOTOR ENCLOSURE

- Fins provide thermal heat dissipation for higher performance

### SERVO MOTOR

- 100% duty cycle for demanding applications
- Internal thermal protection

### HIGH THRUST BEARING

- Oversized bearing supports the leadscrew and motor
- Large shaft and bearings for longer life and tolerance of radial and axial loads

## ICR BASIC - EXCLUSIVE FEATURE

### INTERFACE CONTROLS

- Speed and force controls
- Simple interface that mimics pneumatic valve control
  - Independent extend and retract speed controls
  - Force controls for push and hold or continuous force applications



### FLEXIBLE MOUNTING

- Front face and bottom mounting holes are standard
- Options: front flange, plates, tube clamps, trunnions, rear clevis (RP models only)

## OPTIONS

### MOUNTING

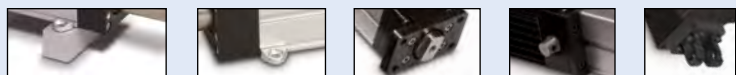

- Plate (M2 or M2)
- Tube Clamps
- Front Flange
- Trunnion
- Clevis

### ROD END



- External Threads
- Clevis
- Eye
- Alignment Coupler

### IP65

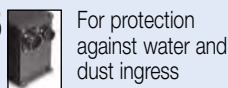

For protection against water and dust ingress

### BRAKE



For vertical applications and energy savings when ICR is not in use

### CABLES

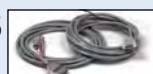

- Signal Cable (5m, IP40 or IP65)
- Power Cable (5m, IP40 or IP65)

### SWITCHES



Styles include: Reed, Solid State PNP or NPN, all available in normally open or normally closed. RoHs compliant, CE rated

## About the ICR Plus

The ICR Plus is an all-in-one (control, drive, motor, actuator) electric rod-style actuator designed for industrial applications, with a powerful, flexible integrated digital drive. The ICR Plus offers programmability, infinite positioning and advanced network communication options.

### CAPABILITIES

- Indexer programming
- Stand-alone operation
- Infinite positioning
- Network communication
  - CANopen
  - DeviceNet
  - RS-232 to CANopen
- Stepper mode (Pulse / direction)
- Analog position mode
- 100% duty cycle for continuous operation
- 8 inputs
- 2 outputs, opto-isolated sinking/sourcing
- 24 Vdc opto-isolated I/O that is NPN or PNP
- IP65 option - For protection against water and dust ingress

## ICR Plus Applications

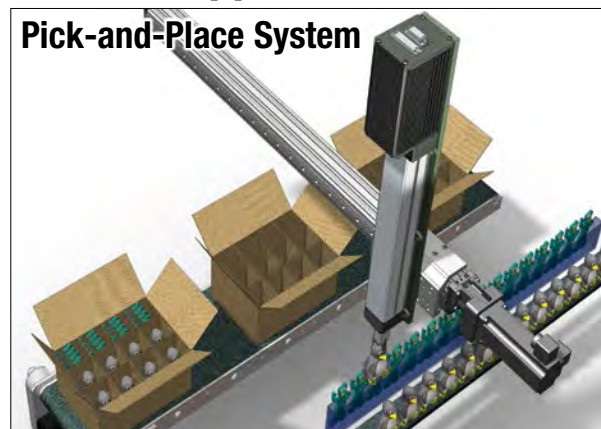

Complex applications utilize flexibility of indexer programming. Examples include:

- Pick and place
- Gantry
- Palletizer
- Cross axis cutter
- Sorter

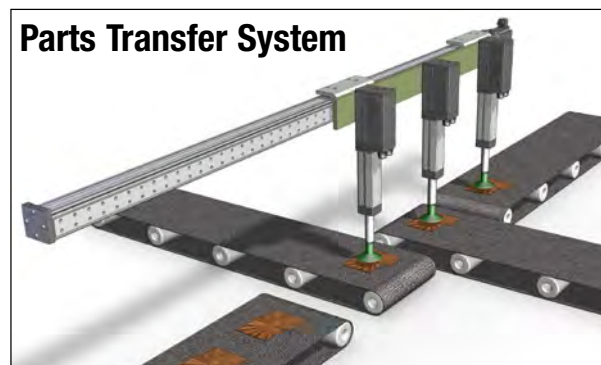

Network communication is utilized to control multiple actuators.

- CANopen - daisy chain up to 127 actuators
- DeviceNet - daisy chain up to 63 actuators
- RS-232 to CANopen - daisy chain up to 127 actuators

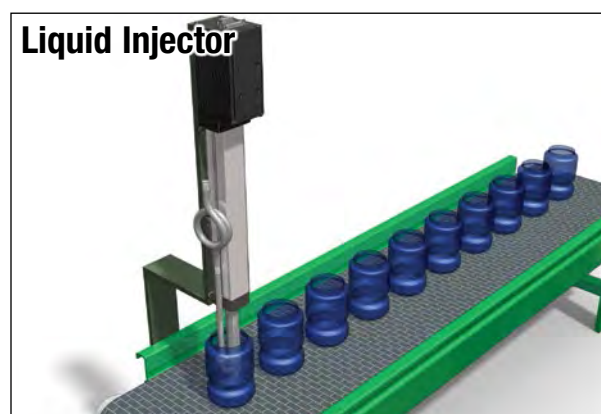

Programmable motion profile allows precise control of position velocity and acceleration. Similar applications include:

- Wire winding
- Slitting
- Positioning
- Test fixtures
- Applying
- Inspection
- Cutting



# ICR Plus Modes of Operation

(choose one)

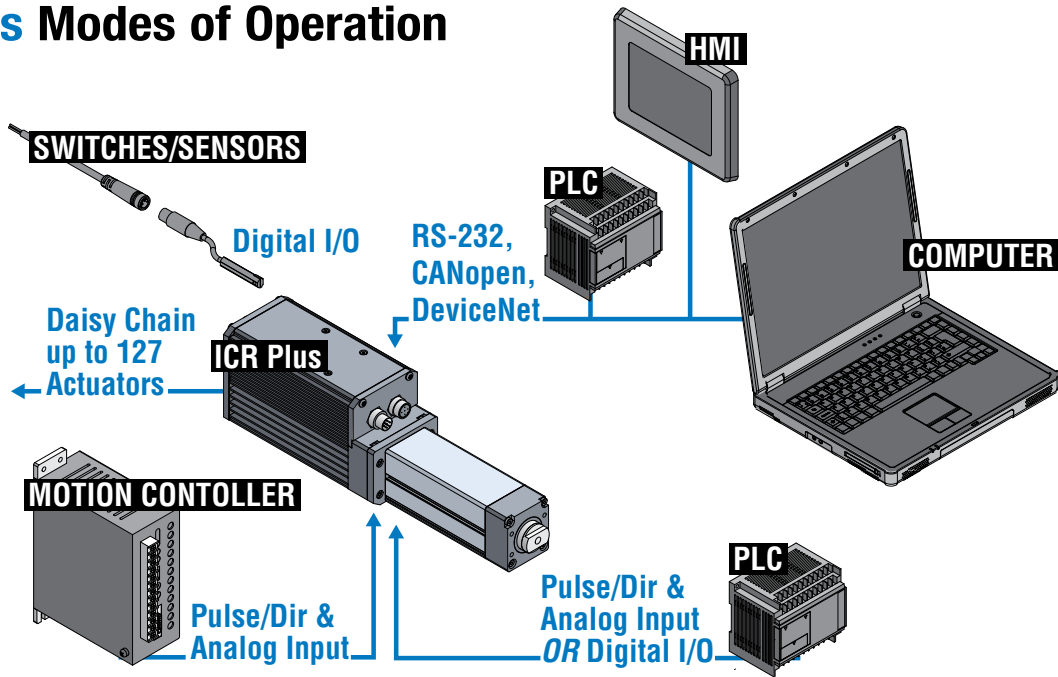

## Powerful Software - Intuitive Interface

### Input / Output

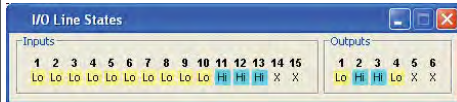

### Control Panel



### Indexer Programming

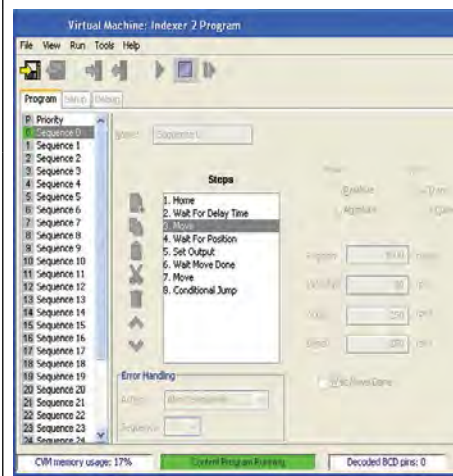

### Oscilloscope

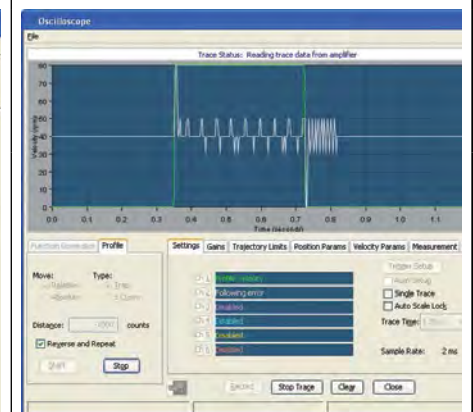

## Flexible Operation

**Stand-alone mode:** PLCs or switches/sensors can send commands to the actuator via digital I/O to invoke indexer program for motion or other logic events.

**Communication mode:** PLC or PC sends position commands or register changes over RS-232, CANopen or DeviceNet. CANopen (127) and DeviceNet (63) can control multiple actuators simultaneously. The RS-232 port can be used as a gateway to the CANopen bus as well. A Microsoft® COM object library is provided to easily utilize the power of CANopen through Windows® development in VB, C++, .NET, LabView and other programming languages.

**Stepper mode:** PLC or motion controller sends pulse/direction commands to actuator initiating motion.

**Analog position mode:** PLC or motion controller sends 0 - 10 VDC analog signal to actuator which equates into an actual position (contact factory for Analog Torque Mode).

# SmartActuator ICR Plus

## INTEGRATED CONTROL ROD-STYLE ACTUATOR

### ENDURANCE TECHNOLOGY<sup>SM</sup>

Endurance Technology features are designed for maximum durability to provide extended service life. This endurance technology symbol indicates our durability design features.

### BALL SCREW TECHNOLOGY

- Oversized ball screw selection for extremely long service life
- Lubricated for life of actuator at the factory with the highest quality synthetic grease



### THRUST TUBE

- Hardened nickel plated steel rod ground and polished for greater durability than stainless steel
- Excellent corrosion resistance from many chemicals and resists incidental contact damage

### INTERNAL BUMPER

- Bumper protects the screw and nut assembly from damage at the end of stroke

### THREADED ROD END

- Nickel plated aluminum for corrosion resistance
- Provides a common interface to multiple rod end options

### ROD WIPER

- Prevents contaminants from entering the housing for extended life of the actuator

### BEARING

- Unique nose bearing material allow smooth operation and support of the thrust rod

### ICR PLUS - EXCLUSIVE OPTION

### COMMUNICATION PORTS



- DeviceNet – daisy chain up to 63 actuators
- Two ports for easy daisy chain wiring
- Optional CANopen – daisy chain up to 127 actuators (CANopen device profile DSP-402)

### MOTOR ORIENTATION

#### YOU CAN CHOOSE

-  In-line option directly couples the driving shaft and is a one-piece housing construction for optimum alignment and support of the motor



-  Reverse-parallel option minimizes the overall length and offers 1:1 or 2:1 belt ratio

### ANTI-ROTATE BEARING

- Engineered resin guide bearings provide anti-rotation of the thrust rod
- Support the thrust tube and nut assembly through entire stroke length

**ICR PLUS - EXCLUSIVE FEATURE**

**DIGITAL DRIVE**

- Advanced indexer programming environment for maximum flexibility to solve the most demanding applications
- CANopen and DeviceNet communications allow daisy chain of up to 127 units. RS-232 port included
- Full suite of software for setup, diagnostics & debug

**DIGITAL ENCODER**

- For closed loop control

**CONNECTORS**

- Standard
- Optional IP65



**ALUMINUM MOTOR ENCLOSURE**

- Fins provide thermal heat dissipation for higher performance

**SERVO MOTOR**

- 100% duty cycle for demanding applications
- Internal thermal protection

**HIGH THRUST BEARING**

- Oversized bearing supports the leadscrew and motor
- Large shaft and bearings for longer life and tolerance of radial and axial loads

**LIGHTWEIGHT ALUMINUM DESIGN**

- Clear anodized extrusion design is optimized for rigidity and strength
- External switch channels and mounting channels along full length on both sides allow easy placement of position indicating switches and tube clamps/mounting plates

**FLEXIBLE MOUNTING**

- Front face and bottom mounting holes are standard
- Options: front flange, plates, tube clamps, trunnions, rear clevis (RP models only)

**OPTIONS**

**MOUNTING**



- Plate (M2 or M3)



- Tube Clamps



- Front Flange



- Trunnion



- Clevis

**ROD END**



- External Threads



- Clevis



- Eye



- Alignment Coupler

**BRAKE**



For vertical applications and energy savings when ICR is not in use

**IP65**



For protection against water and dust ingress

**COMM. PORTS**

For DeviceNet & CANopen, see above

**CABLES**



- Signal Cable (5m, IP40 or IP65)
- Power Cable (5m, IP40 or IP65)
- Communication cable (1m or 5m)

**STARTER KIT**

USB to CANopen converter and comm. cables

**SWITCHES**



Styles include: Reed, Solid State PNP or NPN, all available in normally open or normally closed. RoHs compliant, CE rated

## Need a RODLESS SmartActuator? Choose the ICM Plus

The ICM Plus places an all-in-one (control, drive, motor) solution mounted to your choice of Tolomatic electric rodless or rod-style actuator. The ICM Plus is designed for industrial applications, by combining a flexible integrated digital drive with the power of a servo motor.

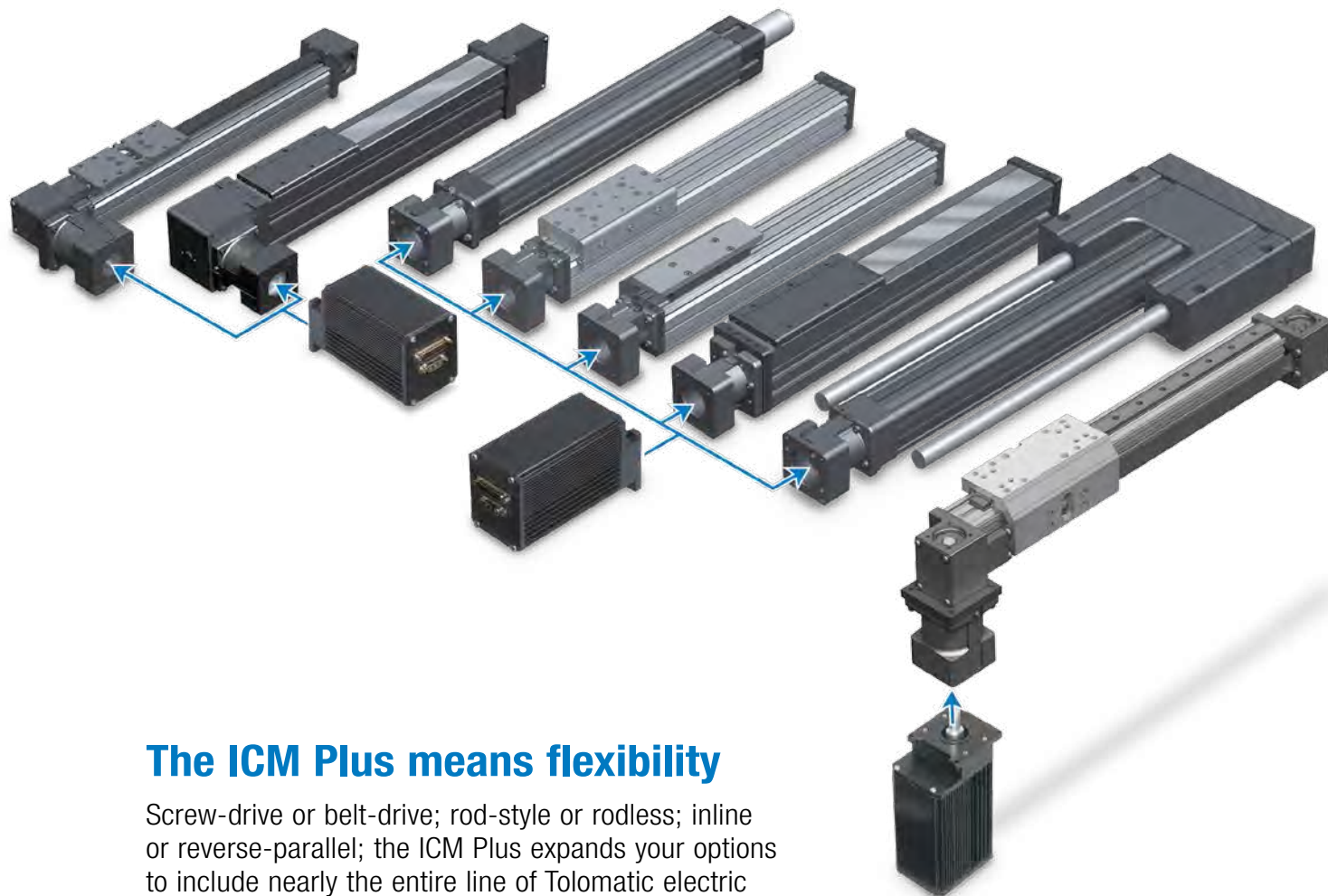

### The ICM Plus means flexibility

Screw-drive or belt-drive; rod-style or rodless; inline or reverse-parallel; the ICM Plus expands your options to include nearly the entire line of Tolomatic electric actuators.

 **NOTE:** The ICM Basic is NOT available on other Tolomatic actuators.



**See the ICM Plus brochure #2100-4008 for information about ICM Plus capabilities and features**



## MECHANICAL SPECIFICATIONS

	Unit	BN02	BN05
<b>Screw Type</b>		Ball	Ball
<b>Screw Pitch</b>	tpi	2	5
<b>Screw Diameter</b>	in	0.75	0.63
	mm	19.1	15.9
<b>Screw Lead</b>	in/rev	0.500	0.200
	mm/rev	12.70	5.08
<b>Screw Static Load</b>	lbf	21,000	6,250
	N	93,413	27,801
<b>Screw Dynamic Load</b>	lbf	3,400	825
	N	15,124	3,670
<b>Back Drive Force*</b>	lbf	7.5	12.5
	N	33.4	55.6
<b>Accuracy</b>	in/ft	0.003	0.003
	mm/m	0.02	0.02
<b>Backlash</b>	in	0.015	0.015
	mm	0.38	0.38
<b>LMI 1:1</b>	lbf	150	400
	N	667	1779
<b>Peak RP 1:1</b>	lbf	142.5	360
	N	633.9	1601
<b>Peak RP 2:1</b>	lbf	285	720
	N	1267.7	3202.7
<b>Continuous LMI 1:1</b>	lbf	80	215
	N	356	956
<b>Continuous RP 1:1</b>	lbf	76	193.5
	N	338	860.7
<b>Continuous RP 2:1</b>	lbf	152	387
	N	676	1721.5
<b>Max Stroke</b>	in	24	24
	mm	609.6	609.6
<b>Base Weight LMI</b>	lb	9.31	7.77
	kg	4.22	3.52
<b>Base Weight RP, 1:1</b>	lb	11.79	10.25
	kg	5.35	4.65
<b>Base Weight RP, 2:1</b>	lb	11.99	10.45
	kg	5.44	4.74
<b>Weight/unit of stroke</b>	lb/in	0.345	0.313
	kg/mm	0.0062	0.0056
<b>Min temp</b>	deg F	50	50
	deg C	10	10
<b>Max temp</b>	deg F	122	122
	deg C	50	50
NOTE: Performance de-rating will be necessary at ambient temperatures greater than 25 deg. C (77 deg F)			
<b>IP rating</b>	std	40	40
<b>IP rating</b>	option	65	65
<b>Max Anti-Rotate Tolerance</b>	degrees	±0.25 to ±1.25	

**RoHS COMPLIANT** RoHs Compliant Components

CE Approval Pending

\*In vertical applications an unpowered ICR will require a brake to maintain position if the load on the actuator exceeds this value.

## BALL SCREW LIFE

### LMI & RP 1:1 RATIO

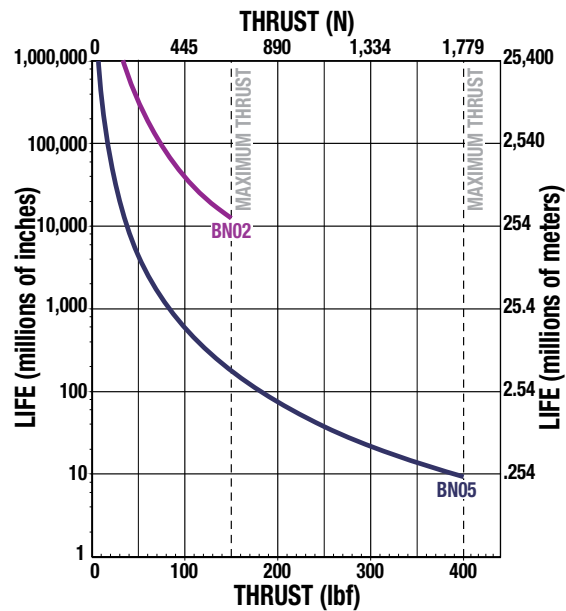

### RP 2:1 RATIO

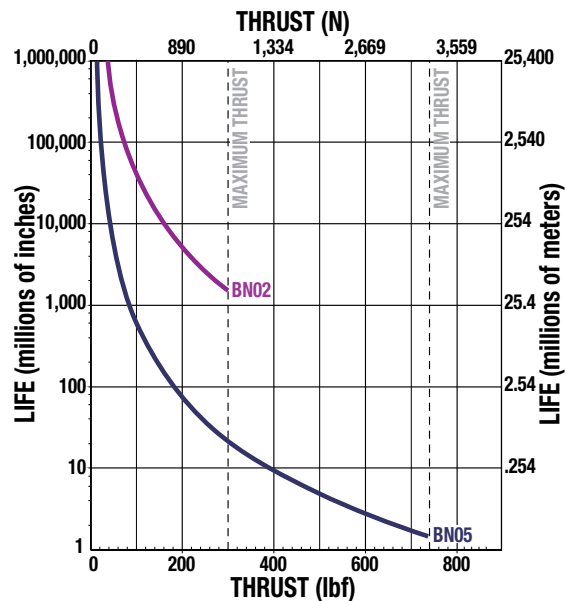

NOTE: The  $L_{10}$  expected life of a ball screw linear actuator is expressed as the linear travel distance that 90% of properly maintained ball screws manufactured are expected to meet or exceed. This is not a guarantee and this graph should be used for estimation purposes only.

The underlying formula that defines this value is:

Travel life in millions of inches, where:

$$L_{10} = \left( \frac{C}{F} \right)^3 =$$

C = Dynamic load rating (lbf)  
F = Cubic mean applied load (lbf)

All curves represent properly lubricated and maintained actuators.



**SPEED vs THRUST**

**BN05**

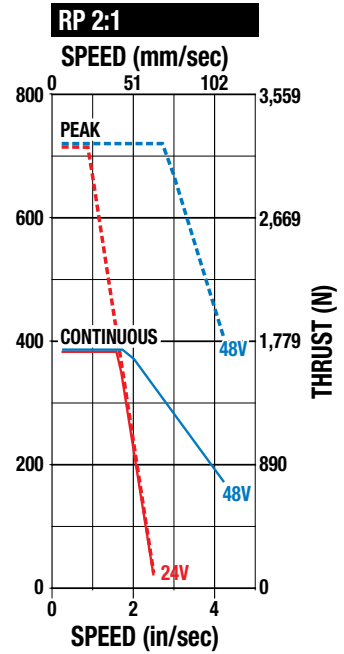
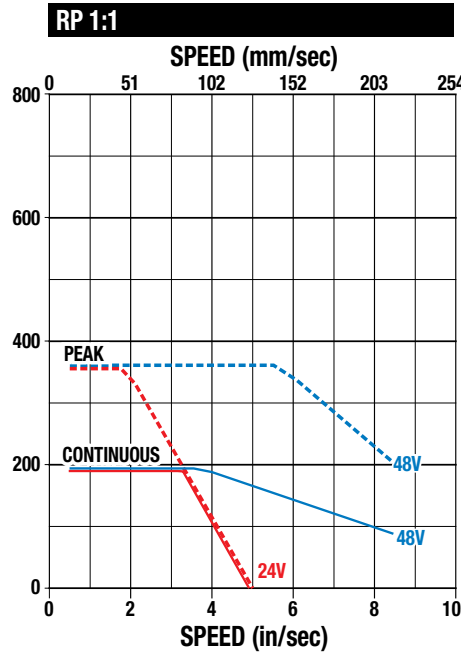
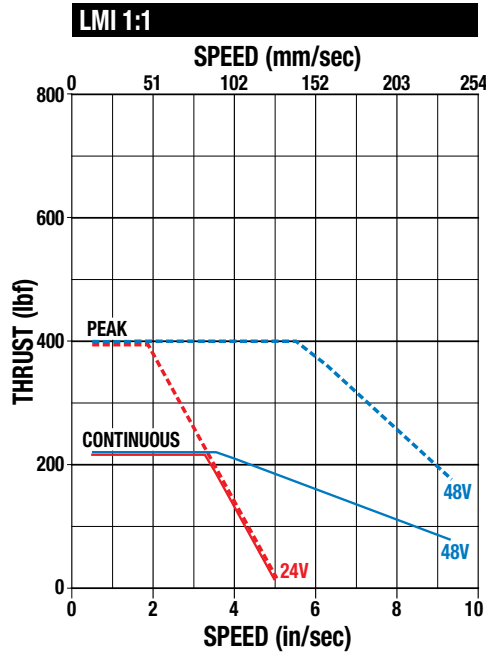

**BN02**

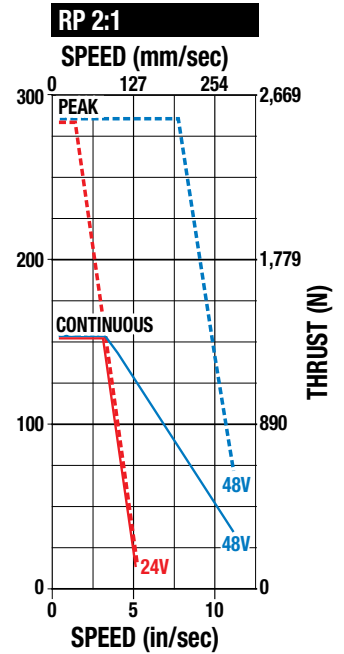
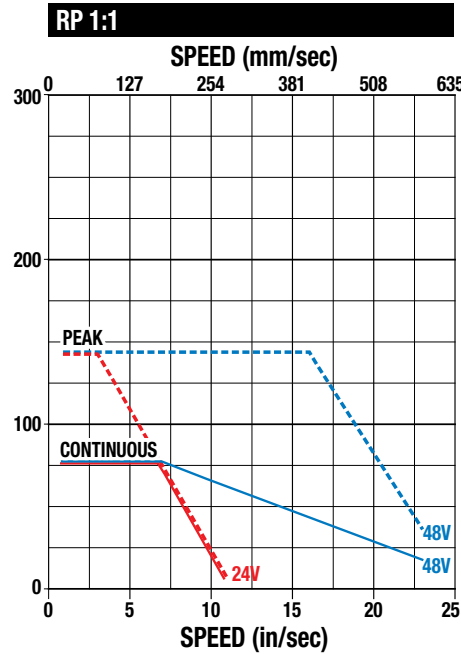
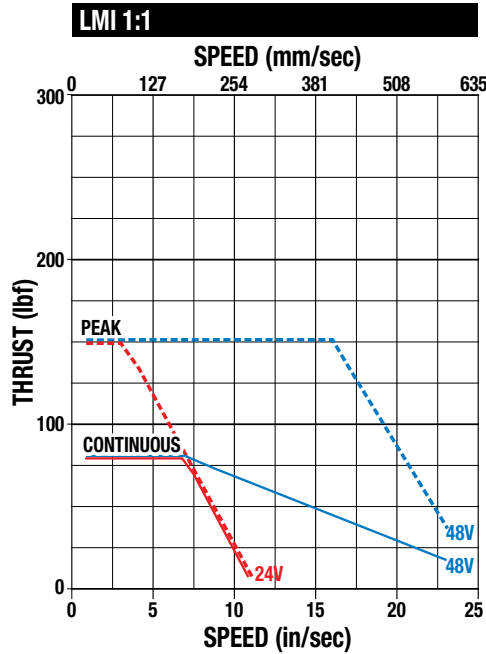

**LEGEND**

24V	—	---
48V	—	---
CONTINUOUS	—	---
PEAK	---	---

**SIDE LOAD CONSIDERATIONS**

Rod screw actuators are designed to push guided and supported loads and are not designed for applications that require significant side loading. Contact Tolomatic for details regarding side loading capabilities.



### CALCULATING RMS THRUST AND VELOCITY

Servo motor actuator systems have two speed/thrust curves: one for continuous duty operation and another for intermittent duty. A servo system can be selected according to the total thrust and maximum velocity indicated by the continuous duty curve. However, by calculating the root mean square (RMS) thrust based on the application duty cycle, you may be able to take advantage of the higher peak thrust available in the intermittent duty range. The RMS thrust must fall within the continuous duty region of the motor/drive and the application maximum thrust must fall under the peak thrust of the actuator. Use the following formulae when calculating the RMS thrust and velocity. When selecting an integrated servo actuator system, it is necessary to add a margin of safety to the thrust and velocity required to move the load. The recommended margin for servo motors is 15%.

$$T_{RMS} = \sqrt{\frac{\sum (T_i^2 \times t_i)}{\sum (t_i)}}$$

$$V_{RMS} = \sqrt{\frac{\sum (V_i^2 \times t_i)}{\sum (t_i)}}$$

Where:

$T_{RMS}$  = RMS Thrust

$V_{RMS}$  = RMS Velocity

$T_i$  = Thrust during interval  $i$

$V_i$  = Velocity during interval  $i$

$t_i$  = Time interval  $i$

### BRAKE CONSIDERATIONS

An unpowered ICR will require a brake to maintain its position if the force on the actuator exceeds:

BN02 screw - 7.5 lbf (33.4 N); BN05 screw - 12.5 lbf (55.6 N)

A brake can be used with the actuator to keep it from backdriving, typically in vertical applications. A brake may be used for safety reasons or for energy savings allowing the actuator to hold position when unpowered. Add **S|A|B** to the ordering code for the optional Spring-Applied/Electronically-Released Brake. (not available for service part ordering)

NOTE: The optional Spring-Applied/Electronically-Released Brake requires 24V power. It has a input current rating of 0.414 Amps.

### ACTUATOR CRITICAL SPEED

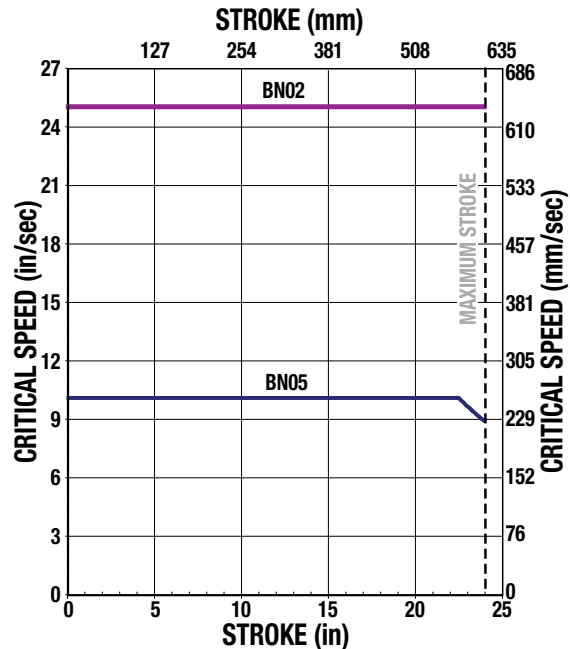

### SYSTEM POWER OVERLOADING CONSIDERATIONS

For applications with large load requirements, care should be taken to prevent the system from generating adverse amounts of power, resulting in overloading and possible failure of the actuator.

Speeds and loads that exceed the amounts indicated in the graph will require the use of a regeneration resistor or some other means to control excess regeneration energy.

Use the Shunt Regulator (part #2180-1163) for preventing over-voltage conditions. Screw terminals are marked with “+” and “-” which should be connected to the power bus.

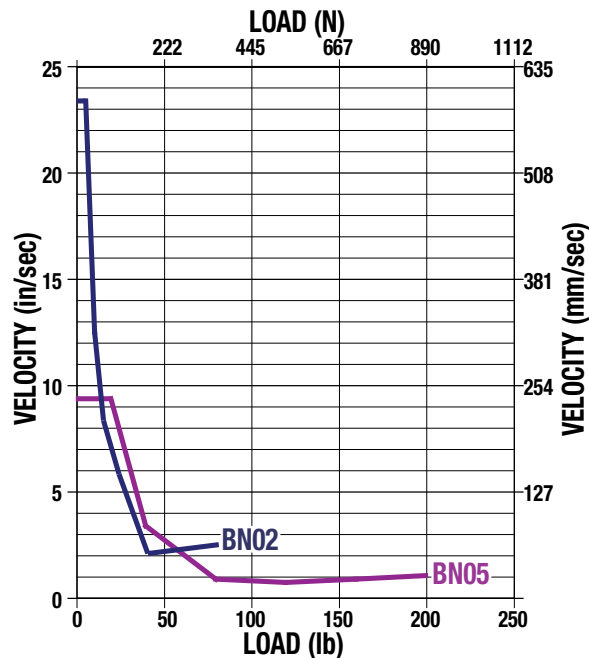

## POWER SUPPLY SIZING GUIDELINES

The ICR Basic and Plus actuators are intended to run off an isolated DC power source. The power supply that is required will depend on the application. A 48V supply will allow the actuator to operate at maximum speed. A 24V supply will result in approximately half the rated velocity. Input current will depend on the actuator power needed in the application. If operating more than one actuator on the same power supply add the required power supply rating for each actuator. Call Tolomatic for help in determining power supply requirements for your application.

**BN05 - 1:1 RATIO (Required Power - Watts)**

SPEED (in/sec)	THRUST (lbf)								
	50	100	150	200	250	300	350	400	
1	51	66	89	118	155	199	251	309	25
2	64	91	124	164	212	265	326	394	51
3	78	116	160	210	266	329	398	473	76
4	94	142	196	255	320	390	465	546	102
5	111	170	233	300	372	448	528	613	127
6	130	198	270	345	422	503	587		152
7	150	228	308	389	472	556			178
8	171	259	346	433	519				203
9	194	290	384	476					229
9.5	206	306	404						241
	222	445	667	890	1112	1334	1557	1779	
	THRUST (N)								SPEED (mm/sec)

**BN02 - 1:1 RATIO (Required Power - Watts)**

SPEED (in/sec)	THRUST (lbf)								
	20	40	60	80	100	120	140	150	
2	26	47	70	95	123	154	186	204	51
4	36	66	98	132	169	208	249	271	102
6	48	86	127	170	216	263	313	339	152
8	61	109	158	210	264	319	377	406	203
10	77	133	191	251	313	376	441	475	254
12	94	159	226	294	363	434	506	543	305
14	113	187	262	338	415	493	572	612	356
16	134	217	300	383	468	552	638	681	406
18	157	248	339	430	522	613			457
20	182	281	380	479	577				508
22	209	316	423	528					559
24	237	353	467						610
	89	178	267	356	445	534	623	667	
	THRUST (N)								SPEED (mm/sec)

**BN05 - 2:1 RATIO (Required Power - Watts)**

SPEED (in/sec)	THRUST (lbf)								
	100	200	300	400	500	600	700	800	
0.5	53	70	93	124	163	209	263	324	13
1.0	67	95	130	173	222	279	343	413	25
1.5	82	122	168	220	280	345	418	496	38
2.0	99	150	206	268	336	409	488	573	51
2.5	117	178	244	315	390	470	555	644	64
3.0	137	208	283	362	443	528	616	708	76
3.5	158	239	323	408	495	584			89
4.0	180	271	363	454					102
4.5	204	305	403	500					114
4.75	216	322	424						121
	445	890	1334	1779	2224	2669	3114	3559	
	THRUST (N)								SPEED (mm/sec)

**BN02 - 2:1 RATIO (Required Power - Watts)**

SPEED (in/sec)	THRUST (lbf)								
	40	80	120	160	200	240	280	300	
1	28	49	73	100	129	161	196	214	25
2	38	69	103	139	177	218	262	285	51
3	50	91	134	179	226	276	329	356	76
4	64	114	166	221	277	335	396	427	102
5	81	140	201	264	329	395	464	498	127
6	99	167	237	309	381	456	532	570	152
7	119	196	275	355	436	517	600	642	178
8	141	228	315	403	491	580	670		203
9	165	261	356	452	548				229
10	191	295	399						254
11	219	332	444						279
12	249								305
	178	356	534	712	890	1068	1246	1334	
	THRUST (N)								SPEED (mm/sec)

Use these tables to help determine the proper power source rating for an application. NOTE: green numbers indicate power supply required in Watts for the given speed and thrust indicated at outside margins.





ACTUATOR DIMENSIONS - LMI

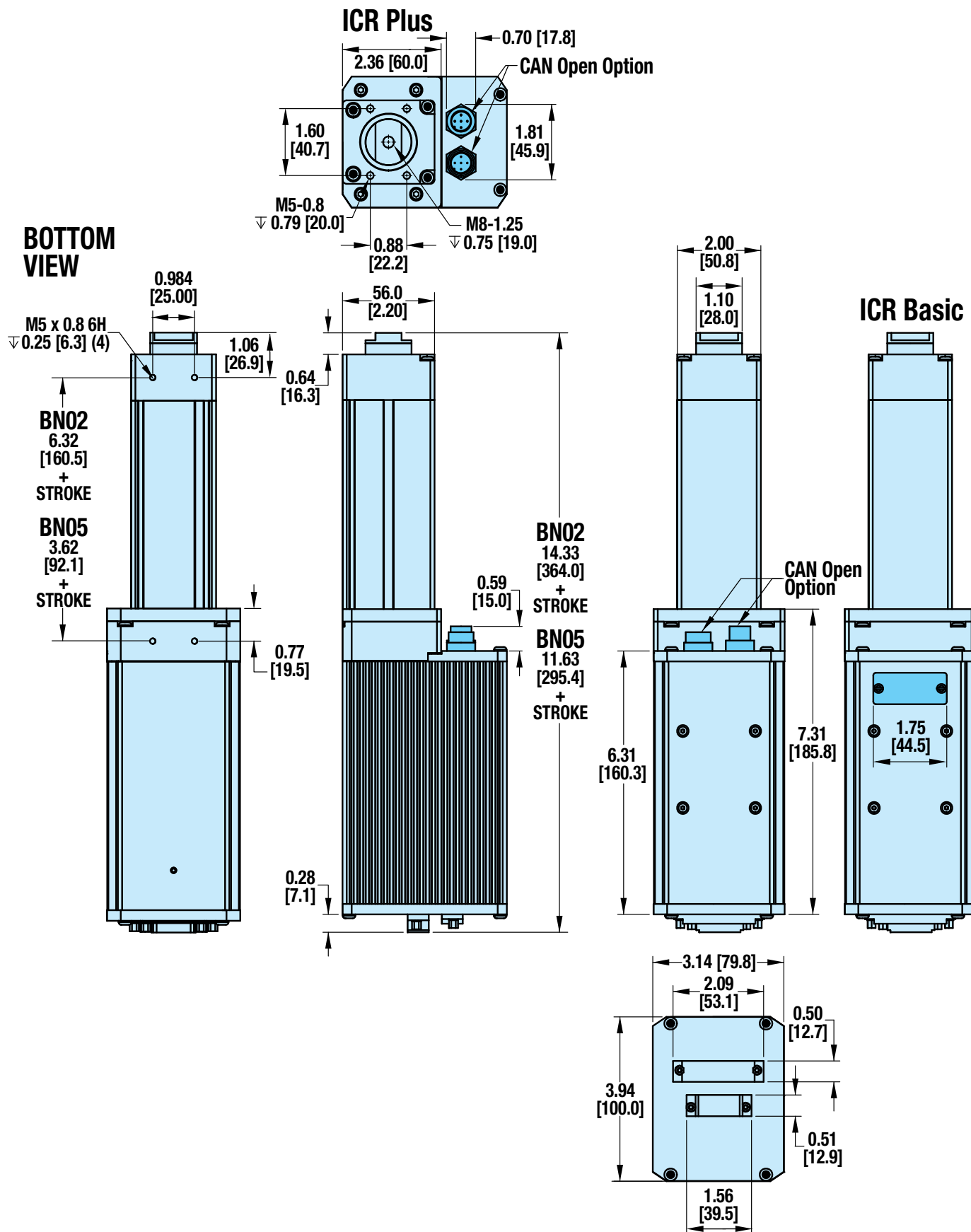

ACTUATOR DIMENSIONS -RP

ICR Plus

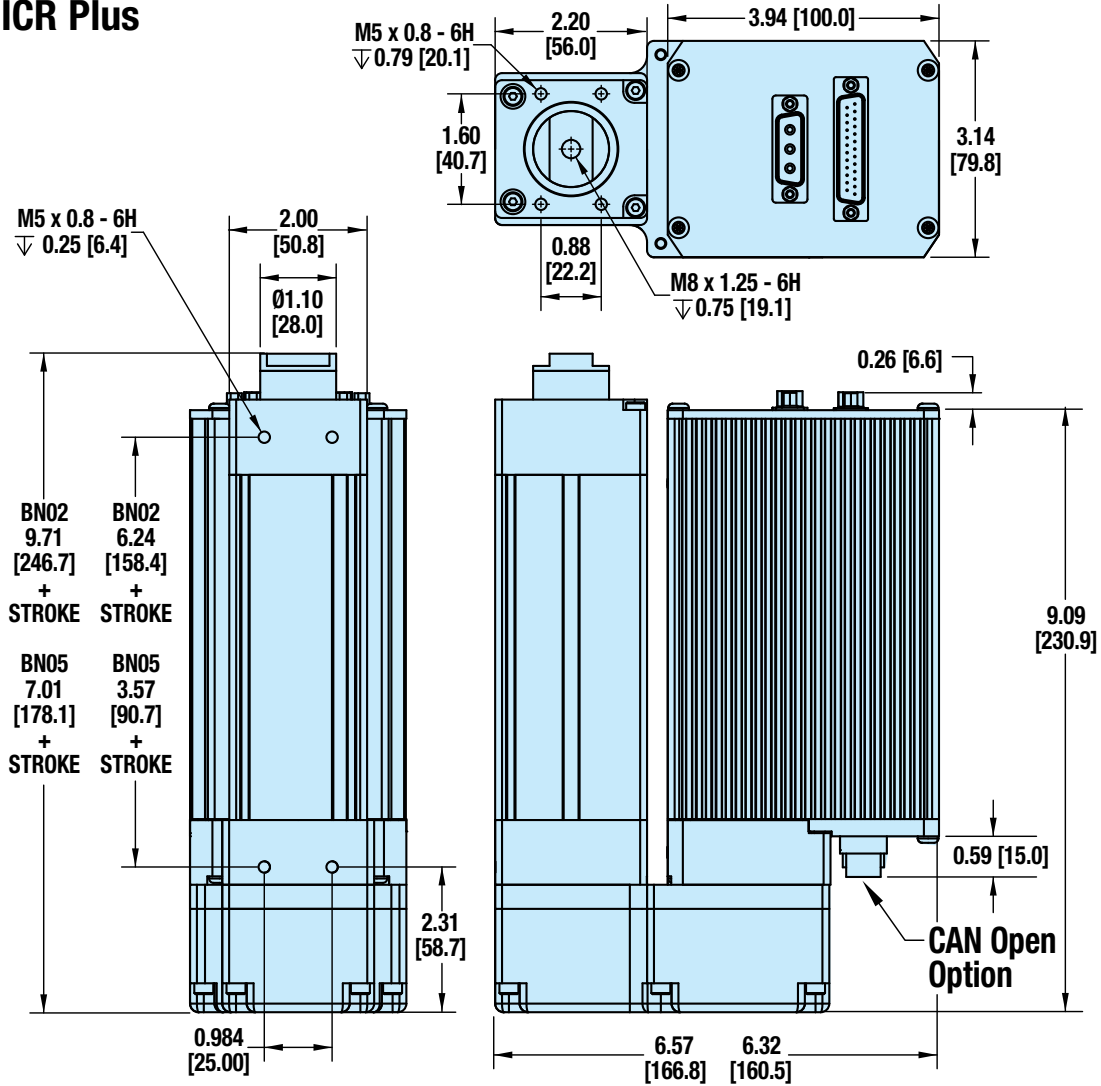

ICR Basic

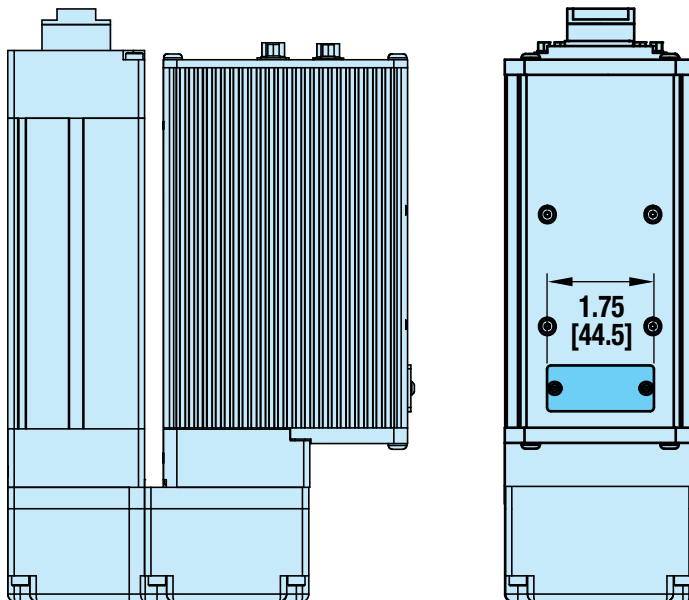



ACTUATOR OPTION DIMENSIONS - LMI

BRAKE

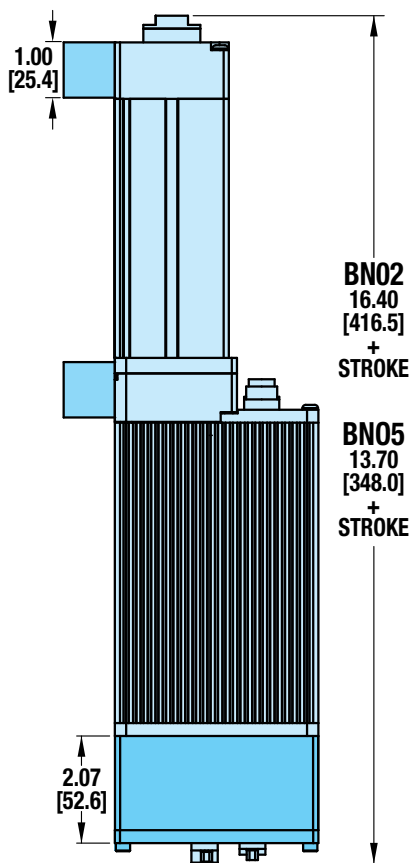

IP65

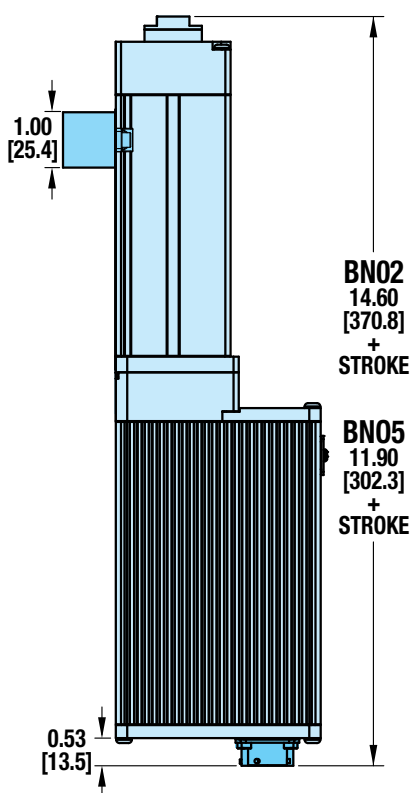

TRUNNION

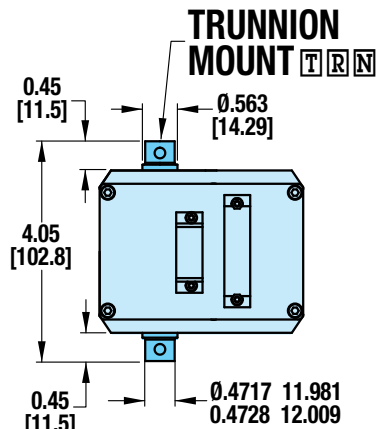
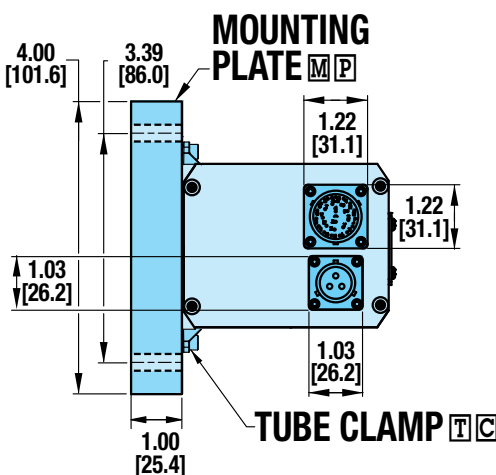
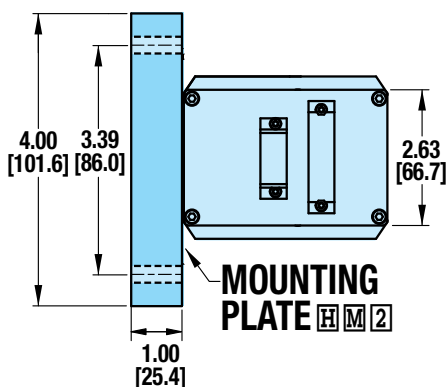
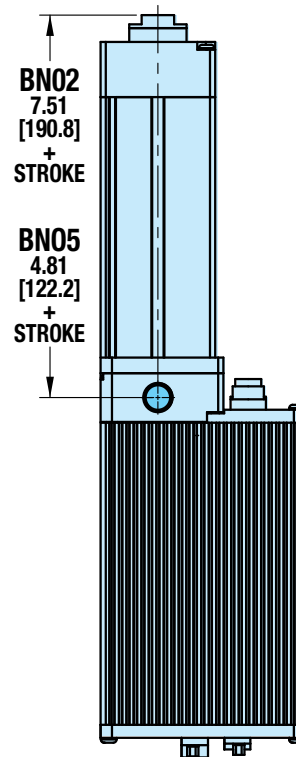

FFG - FRONT FLANGE MOUNT

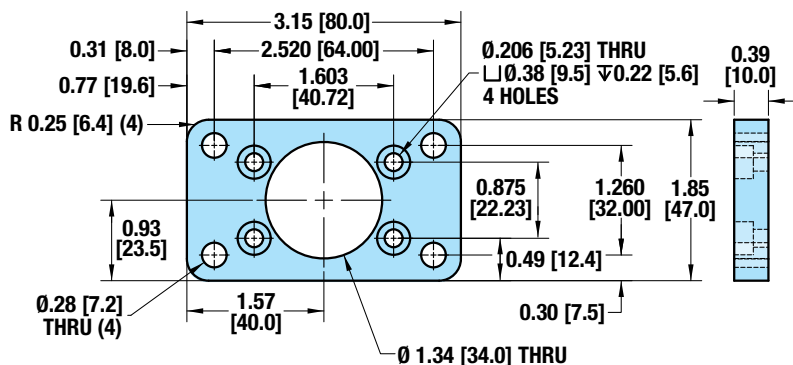

**ACTUATOR OPTION DIMENSIONS - RP**

**BRAKE**

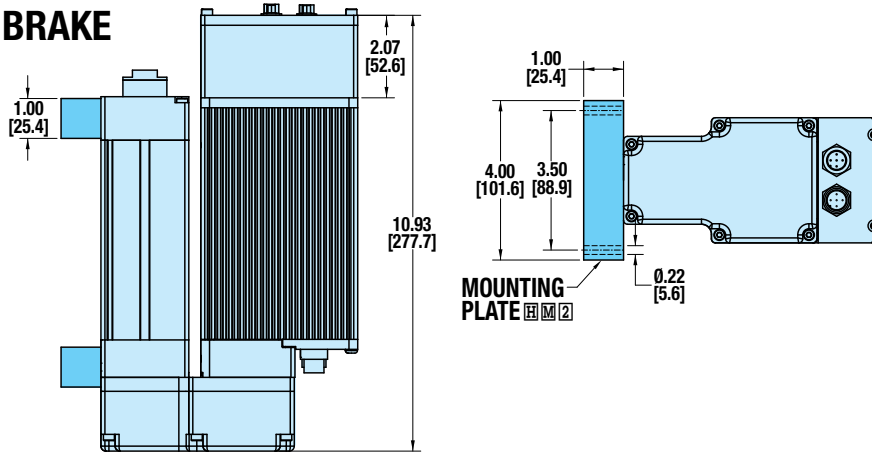

**IP65**

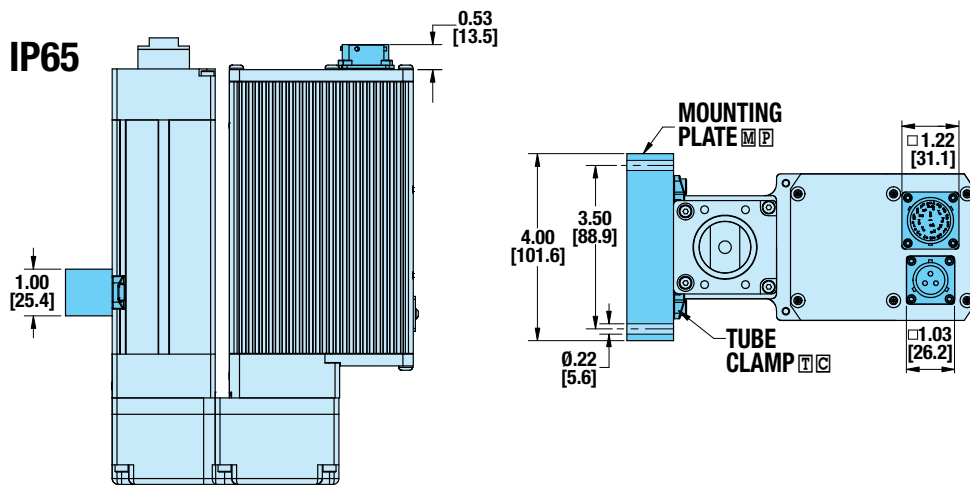

**TRUNNION**

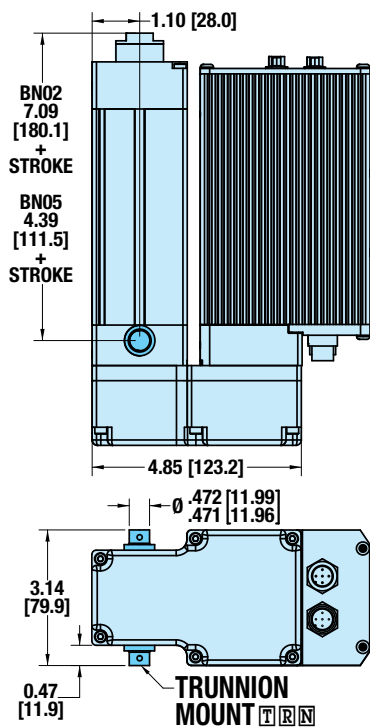

**CLEVIS**

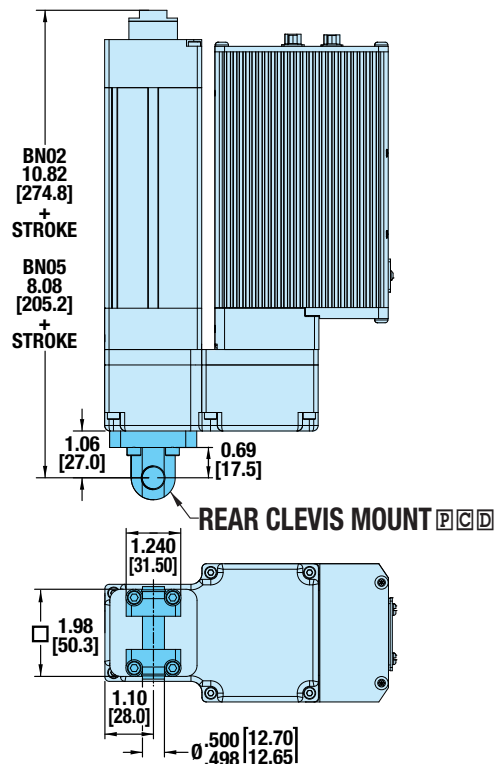



**ACTUATOR ROD END OPTION DIMENSIONS**

**OPTIONAL Spherical Rod Eye End: SRE**

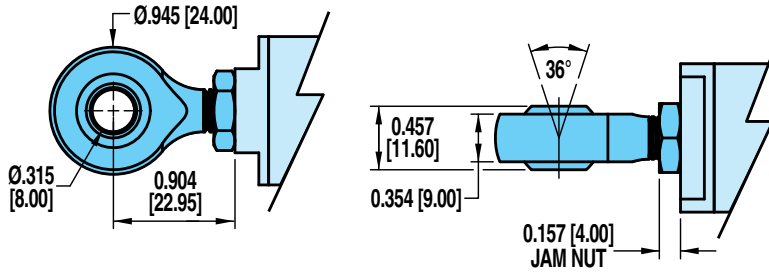

**OPTIONAL Alignment Coupler Rod End: ALC**

**INTERNALLY THREADED END SPECIFIED**

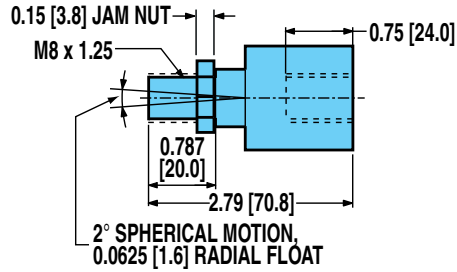

**EXTERNALLY THREADED END SPECIFIED**

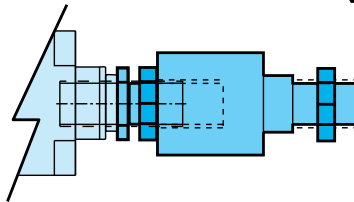
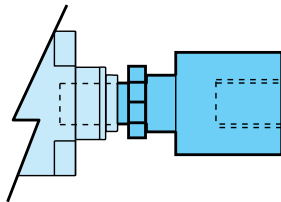
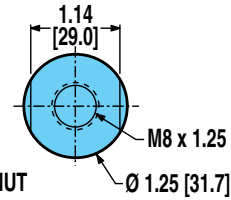
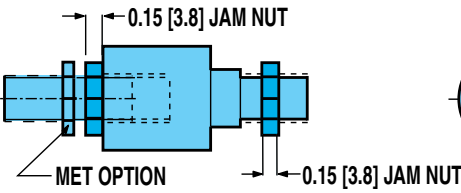

**!** THE ALIGNMENT COUPLER COMES WITH AN INTERNAL THREAD. IF AN EXTERNAL THREAD IS PREFERRED, THE ADDITION OF THE "MET" OPTION IS REQUIRED.

**OPTIONAL External Threaded Rod End: MET**

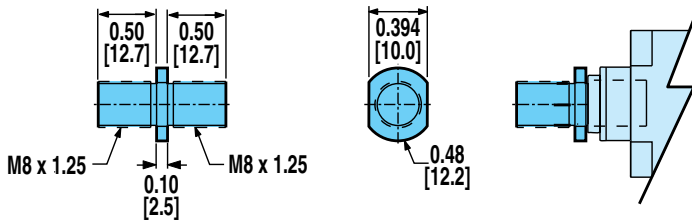

**OPTIONAL Clevis Rod End: CLV**

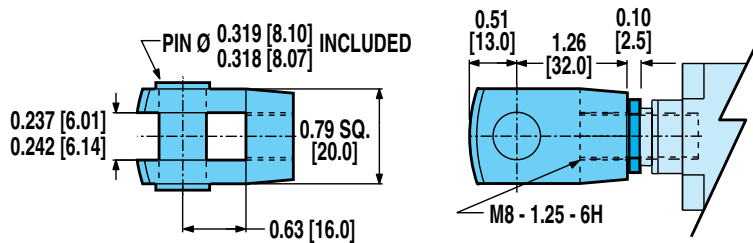

# APPLICATION DATA WORKSHEET Fill in known data. Not all information is required for all applications

## ORIENTATION

Horizontal

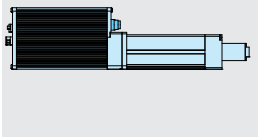

Vertical



Incline °  
 $\alpha$

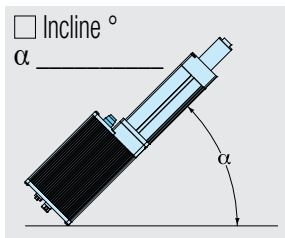

Load supported by actuator OR  Load supported by other mechanism

**ACTUATOR** **FREE - Electric product selection tool at**

**SIZING** **www.tolomatic.com**

Or Call 1-800-328-2174 for  
Excellent Customer Service & Technical Support

## MOVE PROFILE

### EXTEND

Move Distance \_\_\_\_\_

inch  millimeters

Move Time \_\_\_\_\_ sec

Max. Speed \_\_\_\_\_

in/sec  mm/sec

Dwell Time After Move \_\_\_\_\_ sec

### RETRACT

Move Distance \_\_\_\_\_

inch  millimeters

Move Time \_\_\_\_\_ sec

Max. Speed \_\_\_\_\_

in/sec  mm/sec

Dwell Time After Move \_\_\_\_\_ sec

## NO. OF CYCLES \_\_\_\_\_

per minute  per hour

## HOLD POSITION? Required

Not Required

After Move

During Power Loss

## POSITION CONTROL

- Manual Jog
- External Control Signal
- via Position Sensors
- Programmable
- PLC via I/O

## CONTACT INFORMATION

Name, Phone, Email \_\_\_\_\_  
Co. Name, Etc. \_\_\_\_\_

## STROKE LENGTH \_\_\_\_\_

inch (S I) (U.S. Standard)

millimeters (S M) (Metric)

**NOTE:** If load or force changes during cycle use the highest numbers for calculations

### EXTEND

#### LOAD \_\_\_\_\_

lb. (U.S. Standard)

kg. (Metric)

#### FORCE \_\_\_\_\_

lb. (U.S. Standard)

kg. (Metric)

### RETRACT

#### LOAD \_\_\_\_\_

lb. (U.S. Standard)

kg. (Metric)

#### FORCE \_\_\_\_\_

lb. (U.S. Standard)

kg. (Metric)

## POWER SUPPLY \_\_\_\_\_ Amp \_\_\_\_\_

24 Vdc

48 Vdc

## PRECISION

Repeatability \_\_\_\_\_

inch

millimeters

## OPERATING ENVIRONMENT

Temperature, Contamination, etc.

## MOTION PROFILE

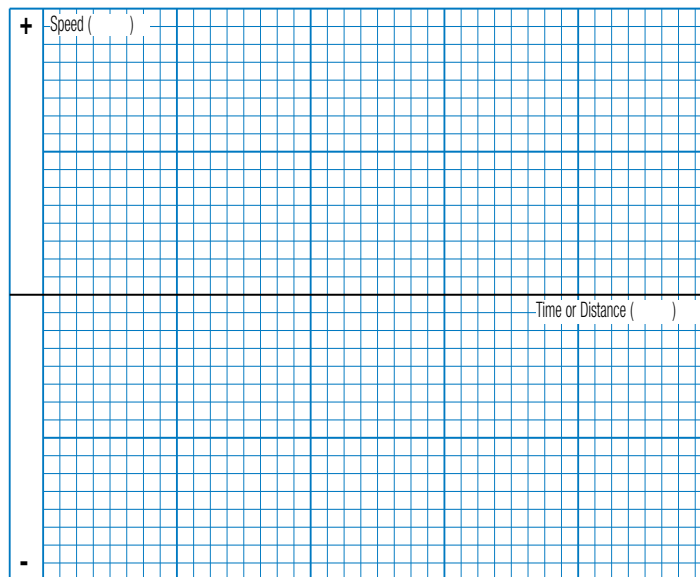

Graph your most demanding cycle, including accel/decel, velocity and dwell times. You may also want to indicate load variations and I/O changes during the cycle. Label axes with proper scale and units.



**USE THE TOLOMATIC SIZING AND SELECTION SOFTWARE AVAILABLE ON-LINE AT [www.tolomatic.com](http://www.tolomatic.com) OR... CALL TOLOMATIC AT 1-800-328-2174.** We will provide any assistance needed to determine the proper actuator for the job.

**FAX 1-763-478-8080**

**EMAIL [help@tolomatic.com](mailto:help@tolomatic.com)**

### Selection Guidelines

#### 1 ESTABLISH MOTION PROFILE

Using the application stroke length and maximum velocity (or time to complete the linear motion), establish the motion profile. For a ICR Basic the factory set acceleration and deceleration is BN05: 22.2 in/sec<sup>2</sup> (564 mm/sec<sup>2</sup>), BN02: 55.6 in/sec<sup>2</sup> (1411 mm/sec<sup>2</sup>). Determine if this acceleration and deceleration allows for desired cycle time. Contact the factory if the acceleration or deceleration needs to be adjusted for an ICR Basic or select the ICR Plus in step 8 for adjustable acceleration and deceleration.

#### 2 COMPARE PEAK THRUST AND SPEED TO PEAK CAPACITIES

Calculate the application required peak thrust and speed and compare to graphs on page ICR\_14.

Select the screw choice that achieves the necessary thrust and speed. Note the difference between a 24 or 48 Volt power supply. The 48 Volt will double the speed of 24 Volt.

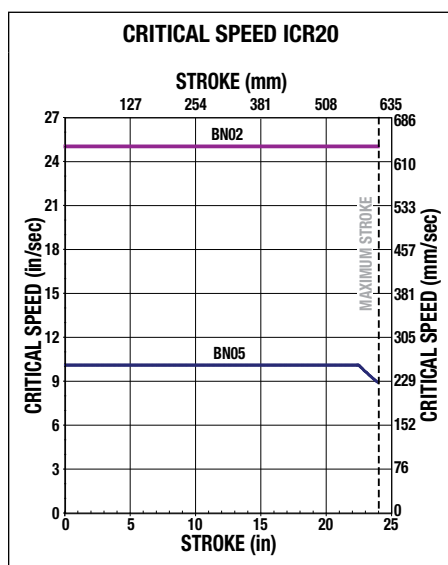

#### 3 COMPARE CONTINUOUS THRUST AND SPEED TO CONTINUOUS CAPACITIES

Calculate the Continuous or RMS thrust and speed required and compare to graphs on page ICR\_14.

Select the screw choice that achieves the necessary thrust and speed for continuous operation. See complete instructions on page ICR\_15 to help calculate continuous force.

$$T_{RMS} = \sqrt{\frac{\sum (T_i^2 \times t_i)}{\sum (t_i)}} \quad v_{RMS} = \sqrt{\frac{\sum (V_i^2 \times t_i)}{\sum (t_i)}}$$

#### 4 BRAKE CONSIDERATIONS

In vertical applications an unpowered ICR will require a spring applied-electronically released brake to maintain position if the load on the actuator exceeds: **BN02:** 7.5 lbf (33.4 N) **BN05:** 12.5 lbf (55.6 N) Refer to page ICR\_15 for more details.

#### 5 POWER LOADING CONSIDERATIONS

Speed and load requirements will determine the power demands of the actuator. To ensure that power overloading does not occur, refer to the graph on page ICR\_15 to determine if a regeneration resistor or similar device is required.

#### 6 POWER SUPPLY SIZING

Size the appropriate power supply using the tables on page ICR\_16. Numbers inside of bold box indicate power supply required in Watts. If operating more than one actuator on the same power supply, add the required power supply rating of each actuator.

#### 7 TEMPERATURE

The ICR is intended to operate in an environment with a temperature between 50-122° F, (10-50° C). Performance is de-rated if the temperature is above 77° F (25° C). Contact the factory if the ambient temperature does not fit within this range.

#### 8 SELECT MOUNTING OPTIONS

Examine mounting options dimensional drawings beginning on page ICR\_19. Choose either inline or reverse parallel motor mounting. Choose to rigidly mount with tapped holes, tube clamps, mounting plates, front flange and alignment coupler. Choose a pivoting mount with trunnion, clevis or eye mount.

NOTE: Temperature at the base of the motor can approach 140°F (60°C)

#### 9 SELECT BASIC OR PLUS MODEL

Determine which model is required for application. An ICR Basic for extend/retract commands with the ability to stop via external I/O. Or the ICR Plus for a fully programmable controller.

#### 10 SELECT OPTIONS

Select options of IP65, cables, and switches.

Call Tolomatic at 1-800-328-2174 for help in determining the best actuator for your application.

## SWITCHES SPECIFICATIONS



ICR products offer a wide range of sensing choices. There are 12 switch choices: reed, solid state PNP (sourcing) or solid state NPN (sinking); in normally open or normally closed; with flying leads or quick-disconnect.

Commonly used for end-of-stroke positioning, these switches allow drop-in installation anywhere along the entire actuator length. The one-piece design includes the retained fastening hardware and is designed for the slot on either the left or right side of the actuator. The magnet is a standard feature and is internally located in the anti-rotate bearing. See the dimensional drawings on page ICR\_25 for details of switch locations. Switches can be installed in the field at any time.

Switches are used to send digital signals to PLC (programmable logic controller), TTL, CMOS circuit or other controller device. Switches contain reverse polarity protection. Solid state QD cables are shielded; shield should be terminated at flying lead end.



All switches are CE rated and are RoHS compliant. Switches feature bright red or yellow LED signal indicators; solid state switches also have green LED power indicators.

	Order Code	Part Number	Lead	Switching Logic	Power LED	Signal LED	Operating Voltage	**Power Rating (Watts)	Switching Current (mA max.)	Current Consumption	Voltage Drop	Leakage Current	Temp. Range	Shock / Vibration
REED	<b>R</b> <b>Y</b>	8100-9082	5m	SPST Normally Open	—	Red	5 - 240 AC/DC	**10.0	100mA	—	3.0 V max.	—	14 to 158°F [-10 to 70°C]	50 G / 9 G
	<b>R</b> <b>K</b>	8100-9083	QD*											
	<b>N</b> <b>Y</b>	8100-9084	5m	SPST Normally Closed	—	Yellow	5 - 110 AC/DC							
	<b>N</b> <b>K</b>	8100-9085	QD*											
SOLID STATE	<b>T</b> <b>Y</b>	8100-9088	5m	PNP (Sourcing) Normally Open	Green	Yellow	10 - 30 VDC	**3.0	100mA	20 mA @ 24V	2.0 V max.	0.05 mA max.		
	<b>T</b> <b>K</b>	8100-9089	QD*											
	<b>K</b> <b>Y</b>	8100-9090	5m	NPN (Sinking) Normally Open	Green	Red								
	<b>K</b> <b>K</b>	8100-9091	QD*											
	<b>P</b> <b>Y</b>	8100-9092	5m	PNP (Sourcing) Normally Closed	Green	Yellow								
	<b>P</b> <b>K</b>	8100-9093	QD*											
	<b>H</b> <b>Y</b>	8100-9094	5m	NPN (Sinking) Normally Closed	Green	Red								
	<b>H</b> <b>K</b>	8100-9095	QD*											

\*QD = Quick-disconnect

Enclosure classification IEC 529 IP67 (NEMA 6)

CABLES: Robotic grade, oil resistant polyurethane jacket, PVC insulation

**⚠️\*\*WARNING:** Do not exceed power rating (Watt = Voltage x Amperage). Permanent damage to sensor will occur.

### SWITCH INSTALLATION AND REPLACEMENT

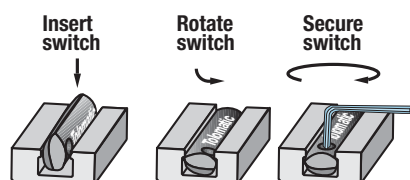

Place switch in side groove on tube at desired location with "Tolomatic" facing outward. While applying light pressure to the switch, rotate the switch halfway into the groove. Maintaining light pressure, rotate the switch in the opposite direction until it is fully inside the groove with "Tolomatic" visible. Re-position the switch to the exact location and lock the switch securely into place by tightening the screw on the switch.



# SWITCHES

## WIRING DIAGRAMS

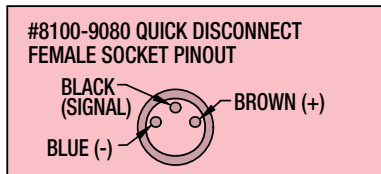
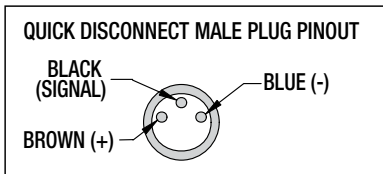
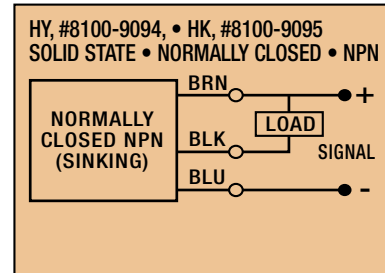
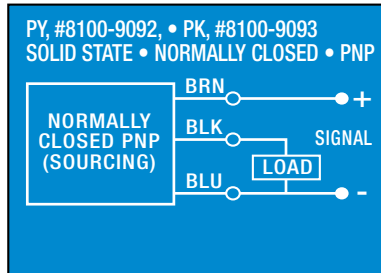
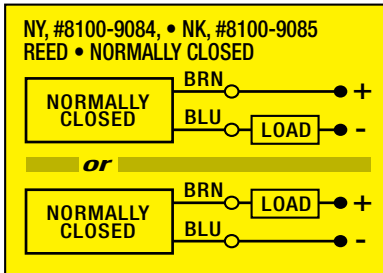
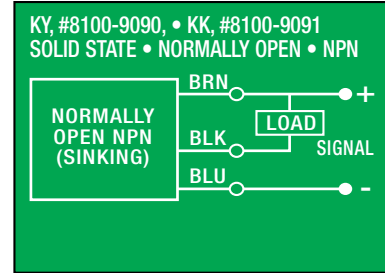
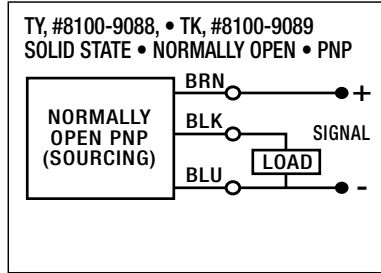
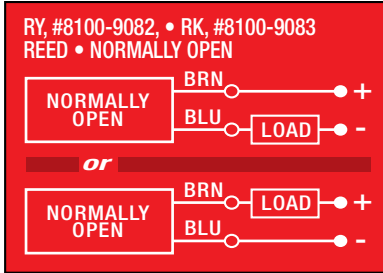

### SWITCH DIMENSIONS

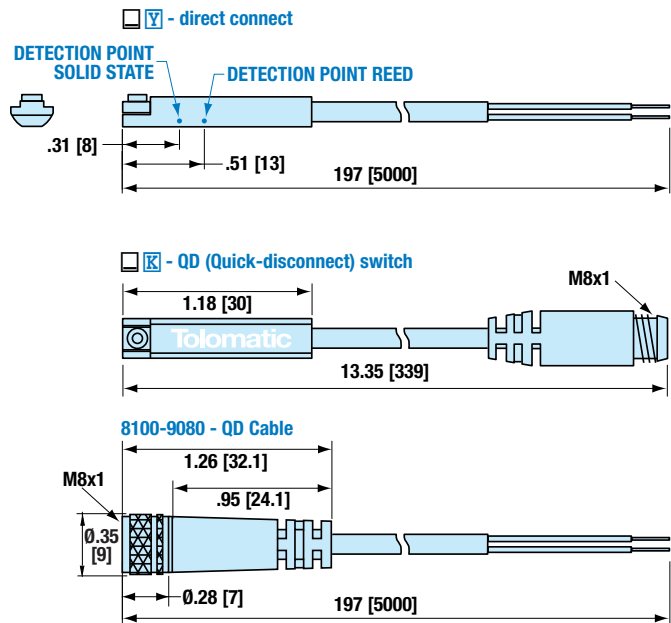

### MOUNTING DIMENSIONS

#### ICR20

SWITCHES SIT BELOW TUBE EXTRUSION PROFILE

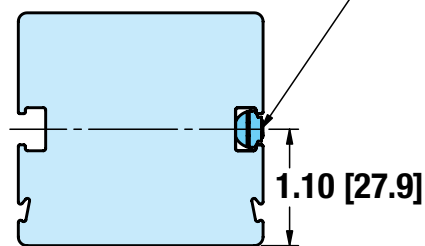

























Dimensions in inches [brackets indicate dimensions in millimeters]

## SERVICE PARTS ORDERING

### SWITCHES

Switches for ICR actuators include retained mounting hardware and are the same for all actuator sizes and bearing styles

Code	Part Number	Lead	Normally	Sensor Type
 	8100-9082	5m (197 in)	Open	Reed
 	8100-9083*	Quick-disconnect		
 	8100-9084	5m (197 in)	Closed	Reed
 	8100-9085*	Quick-disconnect		
 	8100-9088	5m (197 in)	Open	Solid State PNP
 	8100-9089*	Quick-disconnect		
 	8100-9090	5m (197 in)	Open	Solid State NPN
 	8100-9091*	Quick-disconnect		
 	8100-9092	5m (197 in)	Closed	Solid State PNP
 	8100-9093*	Quick-disconnect		
 	8100-9094	5m (197 in)	Closed	Solid State NPN
 	8100-9095*	Quick-disconnect		

\*Also order mating QD cable #8100-9080

	8100-9080	Mating QD (Quick-disconnect) cable 197 in. (5m)
---	-----------	---

### OPTIONS

Description	Part Number	Cable Length
<b>CABLES: ICR Basic or ICR Plus</b>		
Signal Cable: IP40	3604-1640	5m
Signal Cable: IP65	3604-1648	5m
Power Cable: IP40	3604-1641	5m
Power Cable: IP65	3604-1649	5m
<b>CABLES: ICR Plus</b>		
1M DeviceNet / CANopen cable	3604-1659	1m
3M DeviceNet / CANopen cable	3604-1660	5m
Adapter cable for USB to CANopen converter	3604-1626	5m

Description	Part Number
<b>MISCELLANEOUS: ICR Basic or ICR Plus</b>	
Shunt Regulator	2180-1163
<b>MISCELLANEOUS: ICR Plus</b>	
Starter Kit (for use with CANopen, USB computer connections and multi-actuator applications) Includes: USB to CAN converter 3604-1627 Adapter cable for USB to CAN converter 3604-1626 Male terminator resistor 3604-1653	2180-9100
Male terminator resistor	3604-1653
Female terminator resistor	3604-1654
USB to CANopen converter	3604-1627
<b>ROD END KITS: ICR Basic or ICR Plus</b>	
Alignment Coupler Kit	2180-9024
Eye Rod End Kit	2180-9058
Clevis Rod End Kit	2112-9020
Threaded Rod End Kit	2112-1058
<b>MOUNTING KITS: ICR Basic or ICR Plus</b>	
Front Flange Mount Kit	2124-9032
Mounting Plate Kit	2180-9002
Tube Clamp Mount Kit (includes 2 Tube Clamps)	8125-9018
Head Mounting Plate Kit (includes 2 mounts)	2108-9026

## ORDERING

MODEL SELECTION (MUST BE IN THIS ORDER)

OPTIONS (IN ANY ORDER)

**ICR 20P BN05 SM304.8 SV1P LMI CPS CNC5 SAB SRE TC8 TK2**

**MODEL**  
ICR Integrated Control Rod-Style Actuator

**SIZE, Standard or IP65 Option**  
20S 20 Series Actuator, Standard  
20P 20 Series Actuator, IP65 Option

**NUT / SCREW**  
BN02 Ball Nut, 2 turns per inch  
BN05 Ball Nut, 5 turns per inch

**STROKE LENGTH**  
SM \_\_\_\_\_ Stroke, enter desired stroke length in **millimeters**

**MOTOR / DRIVE CONFIGURATION**  
SV1B Servo Motor, Basic Drive  
SV1P Servo Motor, Plus Drive

**MOTOR / DRIVE ORIENTATION**  
LMI In-line orientation (1:1 ratio)  
RP1 Reverse-parallel (1:1 ratio)  
RP2 Reverse-parallel (2:1 ratio)

**CABLES**  
CPS Standard Cables, Power and Signal  
CIP IP65 Cables, Power and Signal

**COMMUNICATION OPTION**  
CNC1 with 1m CANopen/DeviceNet Communication Cable  
CNC5 with 5m CANopen/DeviceNet Communication Cable  
CNC0 CANopen/DeviceNet NO Cables

**BRAKE OPTION**  
SAB Spring-Applied/Electronically-Released Brake  
(For holding position when unpowered)

**ROD END OPTIONS**  
MET Male Externally Threaded Rod End  
SRE Spherical Eye Rod End  
CLV Clevis Rod End  
ALC Alignment Coupler

**MOUNTING OPTIONS**  
MP\_ Mounting Plates, indicate quantity  
HM2 Head Mounting Plates (always 2)  
FFG Front Flange Mount  
TC Tube Clamp, indicate quantity  
TRR Trunnion Mount, Rear  
PCS\* Eye Mount, Rear Clevis, Single  
PCD\* Rear Clevis, Double  
\*NOTE: Available for RP units only

**SWITCHES**

TYPE	LOGIC	NORMALLY	QUICK-DISCONNECT	CODE	QUANTITY	LEAD LENGTH
REED	SPST	Open	no	RY	After code enter quantity desired	5 meters (16.4 feet)
			QD	RK		
		Closed	no	NY		
			QD	NK		
SOLID STATE	PNP	Open	no	TY		
			QD	TK		
	NPN	Open	no	KY		
			QD	KK		
PNP	Closed		no	PY		
			QD	PK		
NPN	Closed		no	HY		
			QD	HK		

VISIT [www.tolomatic.com/icr](http://www.tolomatic.com/icr)  
FOR COMPLETE, UP-TO-DATE INFORMATION

 Not all codes listed are compatible with all options.

Call Tolomatic 1-800-328-2174 to determine available options and accessories based on your application requirements.



See the ICM Plus brochure #2100-4008 for information about capabilities, features and ordering



# THE TOLOMATIC DIFFERENCE

What you expect from the industry leader:



## EXCELLENT CUSTOMER SERVICE & TECHNICAL SUPPORT

Our people make the difference! Expect prompt, courteous replies to all of your application and product questions.



## INDUSTRY LEADING DELIVERIES

Tolomatic continues to offer the fastest delivery of standard catalog products. Modified and custom products ship weeks ahead of the competition.

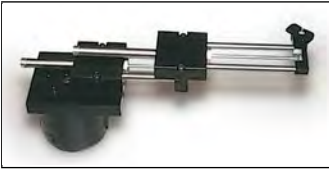

## INNOVATIVE PRODUCTS

From standard catalog products... to modified products... to completely unique custom products, Tolomatic designs and builds the best solutions for your challenging applications.



## ONLINE SIZING & SELECTION SOFTWARE

Online sizing that is easy to use, accurate and always up-to-date. Input your application data and the software will determine a Tolomatic electric actuator to meet your requirements.



## 3D MODELS & 2D DRAWINGS AVAILABLE ON THE WEB

Easy to access CAD files are available in many popular formats.

## ALSO CONSIDER THESE OTHER TOLOMATIC PRODUCTS:

### PNEUMATIC PRODUCTS



*RODLESS CYLINDERS: Band Cylinders, Cable Cylinders, MAGNETICALLY COUPLED CYLINDERS/SLIDES; GUIDED ROD CYLINDER SLIDES*

"FOLDOUT" BROCHURE #9900-9075  
PRODUCTS BROCHURE #9900-4028

### ELECTRIC PRODUCTS



### POWER TRANSMISSION PRODUCTS



*GEARBOXES: Float-A-Shaft®, Slide-Rite®; DISC CONE CLUTCH; CALIPER DISC BRAKES*

"FOLDOUT" BROCHURE #9900-9076  
PRODUCTS BROCHURE #9900-4029

*ROD & GUIDED ROD STYLE ACTUATORS, HIGH THRUST ACTUATORS, SCREW & BELT DRIVE RODLESS ACTUATORS, MOTORS, DRIVES AND CONTROLLERS*

"FOLDOUT" BROCHURE #9900-9074  
PRODUCTS BROCHURE #9900-4016



3800 County Road 116 • Hamel, MN 55340 U.S.A.  
Phone: (763) 478-8000 • Fax: (763) 478-8080

Toll-Free: **1-800-328-2174**

Email: [help@tolomatic.com](mailto:help@tolomatic.com) • <http://www.tolomatic.com>

All brand and product names are trademarks or registered trademarks of their respective owners. Information in this document is believed accurate at time of printing. However, Tolomatic assumes no responsibility for its use or for any errors that may appear in this document. Tolomatic reserves the right to change the design or operation of the equipment described herein and any associated motion products without notice. Information in this document is subject to change without notice.

Visit [www.tolomatic.com](http://www.tolomatic.com) for the most up-to-date technical information

