

# Compact flow rate controller

## RAPIFLOW® FCM

■ Sensor/controller/flow rate controller



### CONTENTS

Product introduction	1330
Applications	1332
Series variation	1333
● FCM	1334
Wiring method	1343
Description of functions and operation	1345
FCM Glossary	1361
▲ Safety precautions	1362

F.R.L
F (Filtr)
R (Reg)
L (Lub)
PresSW
Shutoff
SlowStart
FmResistFR
Oil-ProhR
MedPresFR
No Cu/ PTFE FRL
Outdrs FR
F.R.L (Related)
CompFRL
LgFRL
PrecsR
VacF/R
Clean FR
ElecPneuR
AirBoost
SpdContr
Silncr
CheckV/ other
Jnt/tube
AirUnt
PresCompn
Mech/ ElecPresSw
ContactSW
AirSens
PresSW Cool
AirFloSens/ Contr
WaterPtSens
TotAirSys (Total Air)
TotAirSys (Gamma)
RefrDry
DesicDry
HiPolymDry
MainFiltr
Dischrg etc
Ending

# Compact, high speed, multifunction solution

Microcomputer attains high accuracies and multi-functions

High speed micro machined sensor chip incorporated

## Stainless steel body

■ Applicable fluids/Flow rates

**AIR N<sub>2</sub>**  
0.015 to 50 l/min.

**Ar**  
0.015 to 50 l/min.

**O<sub>2</sub> 13A CH<sub>4</sub> C<sub>3</sub>H<sub>8</sub>**  
0.015 to 10 l/min.

**H<sub>2</sub> He**  
0.06 to 20 l/min.

■ Weight/approx. 480 g

Rectifier mechanism improves low pressure loss and repeatability

Ultimate ideal multi-function flow controller

**Small size flow controller®**

# RAPIFLOW® FCM Series

## Resin body

■ Applicable fluids/Flow rates

0.015 to 100 l/min.

■ Weight/approx. 200 g

F.R.L
F (Filtr)
R (Reg)
L (Lub)
PresSW
Shutoff
SlowStart
FlmResistFR
Oil-ProhR
MedPresFR
No Cu/ PTFE FRL
Outdrs FR
F.R.L (Related)
CompFRL
LgFRL
PrecsR
VacFR
Clean FR
ElecPneR
AirBoost
SpdContr
Silncr
CheckV/ other
Jnt/tube
AirUnt
PrecsCompn
Mech/ ElecPresSw
ContactSW
AirSens
PresSW Cool
AirFloSens/ Contr
WaterRtSens
TotAirSys (Total Air)
TotAirSys (Gamma)
RefrDry
DesicDry
HiPolymDry
MainFiltr
Dischrg etc
Ending



Merging the small size flow sensor FSM and small solenoid valve technologies. The small size flow controller® FCM Series is equipped with sensor functions, proportional control functions and valve functions, all of which have high performance and economic efficiency. This series supports various applications.

## Compatible with various fluids

This series supports various gases including air, nitrogen, argon, oxygen, methane and propane. The new series is compatible with hydrogen and helium, allowing use with a variety of applications.

## New low differential pressure model

The flow of combustion gas with low supply pressure, such as burner thermal power control, can now be controlled.

## Compact and light weight

The size is just 70H × 70D × 30W. Install in a confined space or on a moving place to downsize and lighten your system.

Volume reduction compared to previous model (approx) **30%**

Weight reduction compared to previous model (approx) **20%**



## 0.5 second high speed control

The platinum sensor chip using silicone micro machining achieves 0.5 second high speed control, enabling use in various applications.

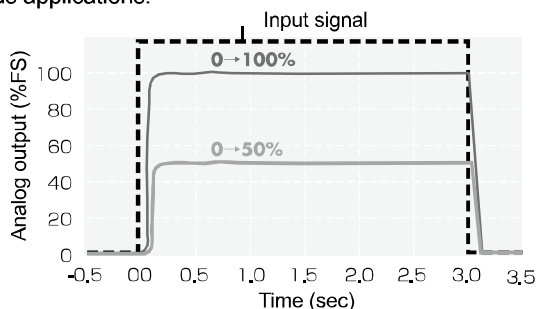

## Dedicated power supply not required

A 24 VDC power voltage allows operation with general-purpose single supplies.

## Highly reliable flow control

CKD's original rectifier control enhances the repeatability affecting flow controllability. Repeatability  $\pm 1\%$  FS Precision  $\pm 3\%$  FS

## RoHS Directive compliant **RoHS**

All substances, such as lead and hexavalent chrome, which could adversely affect the global environment, have been completely eliminated from the materials used in this controller.

## Digital display shows the control state at a glance

- The flow value is displayed digitally with three digits.
- The output state (switch output ON-OFF) is displayed in addition to the error display.

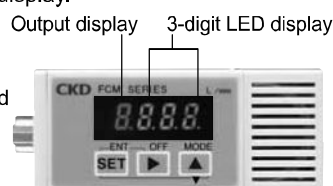

A top/bottom reversed display can be selected according to the installation direction (option)

## Parallel input type available as a standard

Controllable with parallel input(ON/OFF signal for PLC, 10-bit resolution 1024). An analog input/output device, such as a D/A converter, is no longer needed.



## Multi functions with microcomputer

- **Error display function**  
Errors are displayed and notified with electrical signals.
- **Zero/span adjustment function**  
Zero and span can be adjusted according to the usage methods.
- **Preset input function**  
Flow rate can be adjusted by setting 4 random flow rate points with 2-bit signal inputs from an external source (signals from PLC, etc.).
- **Direct memory function**  
Control flow rate can flexibly be adjusted with the product's operation keys even without input signals from an external source.
- **Switch output function**  
A switch output function using the flow rate's upper/lower limit settings is incorporated. (Built-in overcurrent protection)
- **Flow rate integrating function**  
Integral display of the flow rate (max. 6 digits) and pulse outputs for integration are possible.
- **Automatic shutoff function**  
The valves are automatically shut off in an emergency, such as when an error occurs.

F.R.L
F (Filtr)
R (Reg)
L (Lub)
PresSW
Shutoff
SlowStart
PhiResistFR
Oil-ProhR
MedPresFR
No Cu/ PTFE FRL
Outdrs FR
F.R.L (Related)
CompFRL
LgFRL
PrecsR
VacF/R
Clean FR
ElecPneuR
AirBoost
SpdContr
Silncr
CheckV/ other
Jnt/tube
AirUnt
PresCompn
Mech/ ElecPresSw
ContactSW
AirSens
PresSW Cool
AirFloSens/ Contr
WaterPtSens
TotAirSys (Total Air)
TotAirSys (Gamma)
RefrDry
DesicDry
HiPolymDry
MainFiltr
Dischrg etc
Ending

F.R.L
F (Filtr)
R (Reg)
L (Lub)
PresSW
Shutoff
SlowStart
FlmResistFR
Oil-ProhR
MedPresFR
No Cu/ PTFE FRL
Outdrs FR
F.R.L (Related)
CompFRL
LgFRL
PrecsR
VacF/R
Clean FR
ElecPneuR
AirBoost
SpdContr
SiIncr
CheckV/ other
Jnt/tube
AirUnt
PrecsCompn
Mech/ ElecPresSw
ContactSW
AirSens
PresSW Cool
AirFloSens/ Contr
WaterRtSens
TotAirSys (Total Air)
TotAirSys (Gamma)
RefrDry
DesicDry
HiPolymDry
MainFiltr
Dischrg etc
Ending







Used in various fields

RAPIFLOW is available for a wide variety of applications in industries such as machinery, automobiles and precision components, cutting-edge fields such as semiconductors and biotechnology, medical care, foodstuff, and more.

























	Flow rate (l/min) 0.1	1	10	100
Applicable fluids Dry air	<b>Semiconductor</b> <b>Wire bonding</b> Ideal for tension control of wire bonding that requires high precision.		<b>Liquid crystal</b> <b>Floating transport system of glass</b> Ideal for float (non-contact) transportation of large FPD glass.	
	<b>Liquid crystal</b> <b>Flow rate management of</b>		<b>ionizer purge gas</b> Available with a broad flow rate range. Flow rate control of air is possible.	
	<b>Foodstuffs</b> <b>Filling and packaging</b> Ideal for inert gas filling of food packaging, etc.		<b>Semiconductor</b> <b>Purge gas flow rate control</b> Available with a broad flow rate range. Flow rate control of purge gas can be done.	
N <sub>2</sub>	<b>Automobiles, other</b>		<b>Control of N<sub>2</sub> gas in laser oscillator and semiconductor manufacturing equipment</b>	
	<b>Flow rate control of argon gas for welding</b> Available with a broad flow rate range. Flow rate control of argon gas for welding is possible.		<b>Flow rate control of argon gas for welding</b> Available with a broad flow rate range. Flow rate control of argon gas for welding is possible.	
Ar	<b>Glass processing</b> <b>Burner flame control</b> Suitable for controlling burner flame by allowing low pressure gas supply.			
	<b>Combustion gas</b>			
O <sub>2</sub>				
H <sub>2</sub>				



## Applicable fluids/flow rate control range

Model No.	Applicable fluids	Flow rate control range (l/min)					Body material	Port size
		0.01	0.1	1	10	100		
<b>FCM-9500 AI</b>	<b>AIR</b> Air <b>N<sub>2</sub></b> Nitrogen	0.015 to 0.5					<b>Resin</b> 	<b>Resin</b> φ6 push-in φ8 push-in
<b>FCM-0001 AI</b>		0.03 to 1						
<b>FCM-0002 AI</b>		0.06 to 2					<b>SUS</b> 	<b>SUS</b> Rc1/4 9/16-18 UNF
<b>FCM-0005 AI</b>		0.15 to 5						
<b>FCM-0010 AI</b>		0.3 to 10						
<b>FCM-0020 AI</b>		0.6 to 20						
<b>FCM-0050 AI</b>		1.5 to 50						
<b>FCM-0100 AI</b> (resin only)		3 to 100						
<b>FCM-9500 AR</b>	<b>Ar</b> Argon	0.015 to 0.5					<b>SUS</b> 	Rc1/4 9/16-18 UNF
<b>FCM-0001 AR</b>		0.03 to 1						
<b>FCM-0002 AR</b>		0.06 to 2						
<b>FCM-0005 AR</b>		0.15 to 5						
<b>FCM-0010 AR</b>		0.3 to 10						
<b>FCM-0020 AR</b>		0.6 to 20						
<b>FCM-0050 AR</b>		1.5 to 50						
<b>FCM-9500 O<sub>2</sub>/LN/C1/C3</b>	<b>O<sub>2</sub></b> Oxygen <b>13A</b> City gas <b>CH<sub>4</sub></b> Methane <b>C<sub>3</sub>H<sub>8</sub></b> Propane	0.015 to 0.5					<b>SUS</b> 	Rc1/4 9/16-18 UNF
<b>FCM-0001 O<sub>2</sub>/LN/C1/C3</b>		0.03 to 1						
<b>FCM-0002 O<sub>2</sub>/LN/C1/C3</b>		0.06 to 2						
<b>FCM-0005 O<sub>2</sub>/LN/C1/C3</b>		0.15 to 5						
<b>FCM-0010 O<sub>2</sub>/LN/C1/C3</b>		0.3 to 10						
<b>FCM-0002 H<sub>2</sub>/HE</b>	<b>H<sub>2</sub></b> Hydrogen <b>He</b> Helium	0.06 to 2					<b>SUS</b> 	Rc1/4 9/16-18 UNF 1/4" Double barbed fitting 1/4" JXR male fitting
<b>FCM-0005 H<sub>2</sub>/HE</b>		0.15 to 5						
<b>FCM-0010 H<sub>2</sub>/HE</b>		0.3 to 10						
<b>FCM-0020 H<sub>2</sub>/HE</b>		0.6 to 20						

## I/O specifications

Input	Model No.	Output			
		Output method	Specifications	Error output	
 Analog: 0 to 10 V  Preset: 4 points (2 bit) (Note)	<b>FCM-□-□0AN</b>	 Analog	1 to 5 V	NPN	
	<b>FCM-□-□0AP</b>			PNP	
	 Analog: 0 to 5 V  Preset: 4 points (2 bit) (Note)	<b>FCM-□-□0SN</b>	 NPN PNP Switch	NPN	NPN
		<b>FCM-□-□0SP</b>			PNP
 Analog: 4 to 20 mA  Preset: 4 points (2 bit) (Note)		<b>FCM-□-□1AN</b>	 Analog	1 to 5 V	NPN
		<b>FCM-□-□1AP</b>			PNP
	 Analog: 4 to 20 mA  Parallel: 10 bit	<b>FCM-□-□1SN</b>	 NPN PNP Switch	NPN	NPN
		<b>FCM-□-□1SP</b>			PNP
 Analog: 4 to 20 mA  Parallel: 10 bit		<b>FCM-□-□2AN</b>	 Analog	1 to 5 V	NPN
		<b>FCM-□-□2AP</b>			PNP
	 Analog: 4 to 20 mA  Parallel: 10 bit	<b>FCM-□-□2SN</b>	 NPN PNP Switch	NPN	NPN
		<b>FCM-□-□2SP</b>			PNP
 Analog: 4 to 20 mA  Parallel: 10 bit		<b>FCM-□-□PAN</b>	 Analog	1 to 5 V	NPN
		<b>FCM-□-□PAP</b>			PNP
	 Analog: 4 to 20 mA  Parallel: 10 bit	<b>FCM-□-□PSN</b>	 NPN PNP Switch	NPN	NPN
		<b>FCM-□-□PSP</b>			PNP

(Note) Preset 8 points (3 bit) input is available by custom order. (In this case, the external integration reset signal input function cannot be used.) Contact CKD for details.

F.R.L  
F (Filtr)  
R (Reg)  
L (Lub)  
PresSW  
Shutoff  
SlowStart  
FlnResistFR  
Oil-ProhR  
MedPresFR  
No Cu/  
PTFE FRL  
Outdrs FR  
F.R.L  
(Related)  
CompFRL  
LgFRL  
PrescR  
VacF/R  
Clean FR  
ElecPneur  
AirBoost  
SpdContr  
Silncr  
CheckV/  
other  
Jnt/tube  
AirUnt  
PresCompn  
Mech/  
ElecPresSw  
ContactSW  
AirSens  
PresSW  
Cool  
AirFloSens/  
Contr  
WaterPtSens  
TotAirSys  
(Total Air)  
TotAirSys  
(Gamma)  
RefrDry  
DesicDry  
HiPolymDry  
MainFiltr  
Dischrg  
etc  
Ending



Compact flow rate controller  
RAPIFLOW

# FCM Series

- For air, nitrogen, argon, oxygen, city gas, methane, propane (flow rate range: 0.5 to 100 ℓ/min)
- Hydrogen, helium (flow rate range: 0 to 20 ℓ/min)



## FCM Series for air, nitrogen, argon, oxygen, city gas, methane, propane

### Specifications

1 MPa = 10 bar

Descriptions		FCM-[*1] [*2]-[*3] [*4] [*5]								
Valve drive method		Proportional solenoid valve				When not energized: Closed				
		Full scale flow rate	Al (Air, nitrogen)	AR (Argon)	O2 (Oxygen)	LN (City gas)	C1 (Methane)	C3 (Propane)		
Flow rate range	Note 1	Standard model	9500	500 mℓ/min	●	●	●	●	●	
			0001	1 ℓ/min	●	●	●	●	●	
			0002	2 ℓ/min	●	●	●	●	●	
			0005	5 ℓ/min	●	●	●	●	●	
			0010	10 ℓ/min	●	●	●	●	●	
		Low diff press model (SS)	0020	20 ℓ/min	●	●				
			0050	50 ℓ/min	●	●				
			0100	100 ℓ/min (resin)	●					
			L9500	500 mℓ/min	●		●	●	●	
			L0001	1 ℓ/min	●		●	●	●	
Applicable fluids	Note 2	*2	Al	Compressed air, nitrogen	●					
			AR	Argon		●				
			O2	Oxygen (oil-prohibited specifications)			●			
			LN	City gas (13A) Note 3				●		
			C1	Methane (CH4 100%)					●	
			C3	Propane (C3H8 100%)						●
Port size, Body material	*3	*3	H6	φ6 push-in, resin (excluding 50, 100 ℓ/min)	●					
			H8	φ8 push-in, resin	●					
			8A	Rc 1/4, stainless steel	●	●	●	●	●	
			UF	9/16-18UNF, stainless steel	●	●	●	●	●	
Control	Guaranteed accuracy range		3 to 100% F.S.							
	Response time	*1	9500 to 0020, L9500 to L0010	Within 0.5 sec. to setting ±5% F.S. (TYP.)						
			0050 to 0100	Within 1 sec. to setting ±5% F.S. (TYP.)						
	Accuracy		Within ±3% F.S.							
	Repeatability		Within ±1% F.S.							
	Temperature characteristics		Within ±0.2% F.S./°C (25°C (77°F) reference)							
Pressure characteristics		Within ±1% F.S. per 98 kPa (≈14 psi) (standard differential pressure reference)								
Pressure	Standard differential pressure		Note 4		Refer to the separate table					
	Operating differential pressure range		Note 5		Refer to the separate table					
	Max. working pressure		Note 5		Refer to the separate table					
	Proof pressure	*3	H6/H8 (Resin body)	490 kPa (≈71 psi, 4.9 bar)						
		8A/UF (SUS body)	980 kPa (≈140 psi, 9.8 bar)							
Operating ambient temperature, humidity			0 (32°F) to 50°C (122°F), 90% RH or less (no condensation)							
I/O	Input signal/ Preset input	*4	0	0 to 10 VDC (6.7 kΩ) / 4 points (2 bit)						
			1	0 to 5 VDC (10 kΩ) / 4 points (2 bit)						
			2	4 to 20 mADC (250 Ω) / 4 points (2 bit)						
			P	Parallel 10 bit/none						
	Output signal	*5	AN	Analog output: 1 to 5 V (connecting load impedance 500 kΩ and over) Error output: NPN open collector output, 50 mA or less, voltage drop 2.4 V or less						
AP			Analog output: 1 to 5 V (connecting load impedance 500 kΩ and over) Error output: PNP open collector output, 50 mA or less, voltage drop 2.4 V or less							
SN			Switch output: NPN open collector output, 50 mA or less, voltage drop 2.4 V or less Error output: NPN open collector output, 50 mA or less, voltage drop 2.4 V or less							
SP			Switch output: PNP open collector output, 50 mA or less, voltage drop 2.4 V or less Error output: PNP open collector output, 50 mA or less, voltage drop 2.4 V or less							
Flow rate display	Display method		7-segment LED 3-digit, indicator accuracy: control accuracy ±1 digit							
	Display range, display resolution		Refer to the separate table							
Integrating functions			Refer to the separate table							
Power supply	Power supply voltage		24 VDC ± 10% (stabilized power supply with ripple rate 2% or less)							
	Current consumption		Note 11		250mA or less					
Mounting orientation			Unrestricted in vertical/horizontal direction							
Wetted section materials	*3	*3	H6/H8 (Resin body)	Polyamide resin, fluoro rubber, stainless steel, alumina, semiconductor silicon, soldering						
			8A/UF (SUS body)	Stainless steel, fluoro rubber, alumina, semiconductor silicon, soldering						
Weight	*3	*3	H6/H8 (Resin body)	Approx. 200g						
			8A/UF (SUS body)	Approx. 480g						
Degree of protection			IEC standards IP40 or equivalent							
Protection circuit			Note 6		Power reverse connection protection, switch output reverse connection protection, switch output load short-circuit protection					
EMC Directive			EN55011, EN61000-6-2, EN61000-4-2/3/4/6/8							

### Pressure

Standard differential pressure, operating differential pressure Note 4, Note 5

(Standard model)

1 MPa ≈ 145.0 psi, 1 MPa = 10 bar

		Flow rate range *1								
		9500	0001	0002	0005	0010	0020	0050	0100	
Applicable fluids *2	AI	Std diff press (kPa)	50	100	100	100	100	150	200	300
		Operating diff press (kPa)	20 to 150	50 to 200	50 to 250	50 to 250	50 to 250	100 to 300	150 to 300	250 to 350
		Max. working pressure (kPa)	150	200	250	250	250	300	300	350
	AR	Std diff press (kPa)	50	100	100	100	100	150	200	
		Operating diff press (kPa)	20 to 150	50 to 200	50 to 250	50 to 250	50 to 250	100 to 300	150 to 300	
		Max. working pressure (kPa)	150	200	250	250	250	300	300	
	O2	Std diff press (kPa)	50	100	100	100	100			
		Operating diff press (kPa)	20 to 150	50 to 200	50 to 250	50 to 250	50 to 250			
		Max. working pressure (kPa)	150	200	250	250	250			
	LN/C1	Std diff press (kPa)	50	50	50	50	50			
		Operating diff press (kPa)	20 to 150	20 to 150	20 to 150	20 to 150	30 to 150			
		Max. working pressure (kPa)	150	150	150	150	150			
C3	Std diff press (kPa)	50	50	50	50	50				
	Operating diff press (kPa)	20 to 150	20 to 150	20 to 150	20 to 150	30 to 150				
	Max. working pressure (kPa)	150	150	150	150	150				

(Low differential pressure model)

1 MPa = 10 bar

		Flow rate range *1					
		L9500	L0001	L0002	L0005	L0010	
Applicable fluids *2	AI/O2	Std diff press (kPa)	20 (≈2.9 psi)	20 (≈2.9 psi)	20 (≈2.9 psi)	20 (≈2.9 psi)	20 (≈2.9 psi)
	LN/C1	Operating diff press (kPa)	5 (≈0.8 psi) to 50 (≈7.2 psi)	5 (≈0.8 psi) to 50 (≈7.2 psi)	5 (≈0.8 psi) to 50 (≈7.2 psi)	5 (≈0.8 psi) to 50 (≈7.2 psi)	10 (≈1.5 psi) to 50 (≈7.2 psi)
	C3 Note 7	Max. working pressure (kPa)	50 (≈7.2 psi)	50 (≈7.2 psi)	50 (≈7.2 psi)	50 (≈7.2 psi)	50 (≈7.2 psi)

### Display, integrating functions

		Flow rate range *1							
		9500 L9500	0001 L0001	0002 L0002	0005 L0005	0010 L0010	0020	0050	0100
Flow rate display	Display range	0 to 500 ml/min	0.00 to 1.00 l/min	0.00 to 2.00 l/min	0.00 to 5.00 l/min	0.0 to 10.0 l/min	0.0 to 20.0 l/min	0.0 to 50.0 l/min	0 to 100 l/min
	Display resolution	1 ml/min	0.01 l/min	0.01 l/min	0.01 l/min	0.1 l/min	0.1 l/min	0.1 l/min	1 l/min
Integrating functions	Display range	999999 ml	9999.99 l	9999.99 l	9999.99 l	99999.9 l	99999.9 l	99999.9 l	999999 l
	Display resolution	1 ml	0.01 l	0.01 l	0.01 l	0.1 l	0.1 l	0.1 l	1 l
Note 10	Pulse output rate	5 ml	0.01 l	0.02 l	0.05 l	0.1 l	0.2 l	0.5 l	1 l

Note 1: The value converted to volumetric flow rate at standard condition (20°C 1 barometric pressure (101 kPa) relative humidity 65%). Full scale stands for max. scale flow rate in the flow rate range.

Note 2: Use dry gas which does not contain corrosive elements such as chlorine, sulfur or acids, and which is clean and does not contain dust or oil mist. When using compressed air, use clean air compliant with JIS B8392-1: 2012 (ISO 8573-1: 2010) [1: 1: 1 to 1: 6: 2]. Compressed air from the compressor contains drainage-water, oil oxide, foreign substances, etc. To maintain the function of this product, install a filter, air dryer (min. pressure dew point 10°C or less), and oil mist filter (max. oil content 0.1 mg/m<sup>3</sup>) on the primary side (upstream side) of this product.

[Recommended circuit]

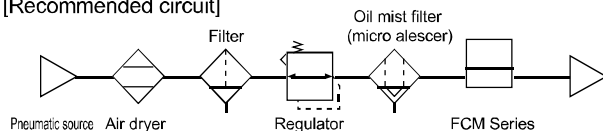

[Recommended device]

Air filter: F series

Oil mist filter: M series

Note 3: The value for city gas 13A is a value for methane (CH<sub>4</sub>) 88% gas generated from LNG.

Note 4: Standard differential pressure is the differential pressure when this product is calibrated. (Secondary side released to atmosphere)

Note 5: Operating differential pressure is the differential pressure required for normal operation of this product. Note that the values depend on the flow rate range and applicable fluids.

The min. value of operating differential pressure is the differential pressure required for the full scale flow rate to flow when secondary side is released to atmosphere. The max. working pressure (max. value of operating differential pressure) is the max. value of primary side pressure. If more pressure is applied, control may become unstable, or the max. flow rate may not be controllable.

Note 6: This product's protection circuit is effective only for specific misconnections and load short-circuits. It does not provide protection for all misconnections.

Note 7: When using a low pressure city gas line (1 to 2.5 kPa), the operating differential pressure range is exceeded.

Note 8: The valve inside this product cannot be used as a stop valve requiring zero leakage. Slight leakage is allowed for in the specifications.

Note 9: The output impedance of the analog output voltage section is approx. 1 kΩ. If the impedance of the connecting load is small, output and error increase. Check error with the impedance of the connecting load before using.

Note 10: The integrating flow is a reference value. It is reset when the power is turned OFF.

Note 11: Current for when 24 VDC is connected, no load is applied, and flow rate is full scale. The current consumption will vary depending on the load.

F.R.L
F (Filtr)
R (Reg)
L (Lub)
PresSW
Shutoff
SlowStart
FlnResistFR
Oil-ProhR
MedPresFR
No Cu/ PTFE FRL
Outdrs FR
F.R.L (Related)
CompFRL
LgFRL
PrescR
VacF/R
Clean FR
ElecPneuR
AirBoost
SpdContr
Silncr
CheckV/ other
Jnt/tube
AirUnt
PresCompn
Mech/ ElecPresSw
ContactSW
AirSens
PresSW Cool
AirFloSens/ Contr
WaterPtSens
TotAirSys (Total Air)
TotAirSys (Gamma)
RefrDry
DesicDry
HiPolymDry
MainFiltr
Dischrg etc
Ending

## FCM Series for hydrogen, helium Specifications

1 MPa ≈ 145.0 psi, 1 MPa = 10 bar

Descriptions		FCM-[*1] [*2]-[*3] [*4] [*5]				
Valve drive method		Proportional solenoid valve When not energized: Closed				
Full scale flow rate		H2 (Hydrogen)		HE (Helium)		
Flow rate range Note 1	*1	0002	2 l/min	●	●	
		0005	5 l/min	●	●	
		0010	10 l/min	●	●	
		0020	20 l/min	●	●	
Applicable fluids Note 2	*2	H2	Hydrogen	●		
		HE	Helium		●	
Port size	*3	8A	Rc1/4	●	●	
		UF	9/16-18UNF	●	●	
		4S	1/4" double barbed fitting	●	●	
		4RM	1/4" JXR male fitting	●	●	
Control	Guaranteed accuracy range		3 to 100% F.S.			
	Response time		*1 Within 0.5 sec. to setting ±5% F.S. (TYP.)			
	Accuracy		Within ±3% F.S.			
	Repeatability		Within ±1% F.S.			
	Temperature characteristics		Within ±0.2% F.S./°C (25°C (77°F) reference)			
	Pressure characteristics		Within ±1% F.S. per 98 kPa (≈14 psi) (standard differential pressure reference)			
Pressure	Standard differential pressure		Note 3	Refer to the separate table		
	Operating differential pressure range		Note 4	Refer to the separate table		
	Max. working pressure		Note 4	Refer to the separate table		
	Proof pressure			980 kPa (≈140 psi, 9.8 bar)		
Operating ambient temperature, humidity		0 (32°F) to 50°C (122°F), 90% RH or less (no condensation)				
External leakage		1 x 10 <sup>-6</sup> Pa·m <sup>3</sup> /s or less (helium leakage rate)				
I/O	Input signal/ Preset input	*4	0	0 to 10 VDC (6.7kΩ) / 4 points (2 bit)		
			1	0 to 5 VDC (10kΩ) / 4 points (2 bit)		
			2	4 to 20 mADC (250 Ω) / 4 points (2 bit)		
			P	Parallel 10 bit/none		
	Output signal	*5	AN	Analog output: 1 to 5 V (connecting load impedance 500 kΩ and over) Error output: NPN open collector output, 50 mA or less, voltage drop 2.4 V or less		
			AP	Analog output: 1 to 5 V (connecting load impedance 500 kΩ and over) Error output: PNP open collector output, 50 mA or less, voltage drop 2.4 V or less		
			SN	Switch output: NPN open collector output, 50 mA or less, voltage drop 2.4 V or less Error output: NPN open collector output, 50 mA or less, voltage drop 2.4 V or less		
			SP	Switch output: PNP open collector output, 50 mA or less, voltage drop 2.4 V or less Error output: PNP open collector output, 50 mA or less, voltage drop 2.4 V or less		
Flow rate display	Display method		7-segment LED 3-digit, indicator accuracy: control accuracy ±1 digit			
Flow rate display	Display range, display resolution		Refer to the separate table			
Integrating functions		Refer to the separate table				
Power supply	Power supply voltage		24 VDC ± 10% (stabilized power supply with ripple rate 1% or less)			
	Current consumption		Note 9	270 mA or less		
Mounting orientation		Unrestricted in vertical/horizontal direction				
Wetted section materials		Stainless steel, fluoro rubber, alumina, semiconductor silicon, soldering				
Weight	*3	8A/UF		Approx. 480 g		
		4S/4RM		Approx. 560 g		
Degree of protection		IEC standards IP40 or equivalent				
Protection circuit		Note 5	Power reverse connection, switch output reverse connection, switch output load short-circuit			
EMC Directive		EN55011, EN61000-6-2, EN61000-4-2/3/4/6/8				



### Pressure

Standard differential pressure, operating differential pressure

1 MPa = 10 bar

			Flow rate range *1			
			0002	0005	0010	0020
Applicable fluids *2	H2	Std diff press (kPa)	20 (≈2.9 psi, 0.2 bar)	50 (≈7.3 psi, 0.5 bar)	50 (≈7.3 psi, 0.5 bar)	50 (≈7.3 psi, 0.5 bar)
		Operating diff press (kPa)	10 (≈1.5 psi) to 50 (≈7.2 psi)	30 (≈4.4 psi) to 80 (≈12 psi)	30 (≈4.4 psi) to 80 (≈12 psi)	30 (≈4.4 psi) to 80 (≈12 psi)
		Max. working pressure (kPa)	50 (≈7.2 psi, 0.5 bar)	80 (≈12 psi, 0.8 bar)	80 (≈12 psi, 0.8 bar)	80 (≈12 psi, 0.8 bar)
	HE	Std diff press (kPa)	50 (≈7.3 psi, 0.5 bar)	100 (≈15 psi, 1 bar)	100 (≈15 psi, 1 bar)	100 (≈15 psi, 1 bar)
		Operating diff press (kPa)	20 (≈3 psi) to 100 (≈15 psi)	50 (≈7.3 psi) to 150 (≈22 psi)	50 (≈7.3 psi) to 150 (≈22 psi)	50 (≈7.3 psi) to 150 (≈22 psi)
		Max. working pressure (kPa)	100 (≈15 psi, 1 bar)	150 (≈22 psi, 1.5 bar)	150 (≈22 psi, 1.5 bar)	150 (≈22 psi, 1.5 bar)

### Display, integrating functions

			Flow rate range *1			
			0002	0005	0010	0020
Flow rate display	Display range	0.00 to 2.00 l/min	0.00 to 5.00 l/min	0.0 to 10.0 l/min	0.0 to 20.0 l/min	
	Display resolution	0.01 l/min	0.01 l/min	0.1 l/min	0.1 l/min	
Integrating functions	Display range	9999.99 l	9999.99 l	99999.9 l	99999.9 l	
	Display resolution	0.01 l	0.01 l	0.1 l	0.1 l	
	Note 8 Pulse output rate	0.02 l	0.05 l	0.1 l	0.2 l	

Note 1: Flow rate converted to volumetric flow rate at 20°C, 1 barometric pressure (101 kPa). Full scale stands for max. scale flow rate in the flow rate range.

Note 2: Use dry gas which does not contain corrosive elements such as chlorine, sulfur or acids, and which is clean and does not contain dust or oil mist.

Note 3: Standard differential pressure is the differential pressure when this product is calibrated. (Secondary side released to atmosphere)

Note 4: Operating differential pressure is the differential pressure required for normal operation of this product. Note that the values depend on the flow rate range and applicable fluids.

The min. value of operating differential pressure is the differential pressure required for the full scale flow rate to flow when secondary side is released to atmosphere. The max. working pressure (max. value of operating differential pressure) is the max. value of primary side pressure. If more pressure is applied, control may become unstable, or the max. flow rate may not be controllable.

Note 5: This product's protection circuit is effective only for specific misconnections and load short-circuits. It does not provide protection for all misconnections.

Note 6: The valve inside this product cannot be used as a stop valve requiring zero leakage. Slight leakage is allowed for in the specifications.

Note 7: The output impedance of the analog output voltage section is approx. 1 kΩ. If the impedance of the connecting load is small, output and error increase. Check error with the impedance of the connecting load before using.

Note 8: The integrating flow is a calculated (reference) value. It is reset when the power is turned OFF.

Note 9: Flow rate for when 24 VDC is connected, no load is applied, and flow rate is full scale. The current consumption will vary depending on the load.

F.R.L
F (Filtr)
R (Reg)
L (Lub)
PresSW
Shutoff
SlowStart
FlnResistFR
Oil-ProhR
MedPresFR
No Cu/ PTFE FRL
Outdrs FR
F.R.L (Related)
CompFRL
LgFRL
PrescR
VacF/R
Clean FR
ElecPneuR
AirBoost
SpdContr
Silncr
CheckV/ other
Jnt/tube
AirUnt
PresCompn
Mech/ ElecPresSw
ContactSW
AirSens
PresSW Cool
AirFloSens/ Contr
WaterPtSens
TotAirSys (Total Air)
TotAirSys (Gamma)
RefrDry
DesicDry
HiPolymDry
MainFiltr
Dischrg etc
Ending

■ For air, nitrogen, argon, oxygen, city gas, methane, propane

## How to order

**FCM - 9500 AI - H6 0 AN R 1 B T**

Model No.

① Traceability  
② Bracket

③ Flow rate range

④ Applicable fluid

⑤ Port size, body material

⑥ Input signal

⑦ Output specifications

⑧ Display direction

⑨ Cable

[Example of model No.]

### FCM-0001AI-H81ANR1BK

Model name: Compact flow rate controller RAPIFLOW®FCM

- ③ Flow rate range : 0 to 1 ℓ/min
- ④ Applicable fluid : Compressed air, nitrogen
- ⑤ Port size, body material : Push-in (φ8), resin body
- ⑥ Input signal : Analog 0 to 5 VDC
- ⑦ Output specifications : 1 to 5 V analog, error (NPN)
- ⑧ Display direction : Reverse direction
- ⑨ Cable : 1 m
- ② Bracket : With bracket
- ① Traceability : With company certification

### ⚠ Precautions for model No. selection

\*1: Refer to dimensions on page 1340 for shape of 9/16-18UNF thread.

### Discrete option model No.

**FCM - AC1**

Code	Content
AC1	Analog 9-conductor, 1 m cable
AC3	Analog 9-conductor, 3 m cable
PC1	Parallel 15-conductor, 1 m cable
PC3	Parallel 15-conductor, 3 m cable
LB1	Bracket

Code	Content					
<b>③ Flow rate range</b>						
Applicable fluid						
	AI	AR	O2	LN	C1	C3
9500	●	●	●	●	●	●
0001	●	●	●	●	●	●
0002	●	●	●	●	●	●
0005	●	●	●	●	●	●
0010	●	●	●	●	●	●
0020	●	●	●	●	●	●
0050	●	●	●	●	●	●
0100	●	●	●	●	●	●
Standard model						
	AI	AR	O2	LN	C1	C3
L9500	●	●	●	●	●	●
L0001	●	●	●	●	●	●
L0002	●	●	●	●	●	●
L0005	●	●	●	●	●	●
L0010	●	●	●	●	●	●
Low differential pressure model (stainless steel only)						
	AI	AR	O2	LN	C1	C3
L9500	●	●	●	●	●	●
L0001	●	●	●	●	●	●
L0002	●	●	●	●	●	●
L0005	●	●	●	●	●	●
L0010	●	●	●	●	●	●

④ Applicable fluid	
AI	Compressed air, nitrogen gas
AR	Argon
O2	Oxygen (oil-prohibited specifications)
LN	City gas (13A)
C1	Methane (CH <sub>4</sub> )
C3	Propane (C <sub>3</sub> H <sub>8</sub> )

⑤ Port size, body material						
Applicable fluid						
	AI	AR	O2	LN	C1	C3
H6	Push-in (φ6), resin body (Flow rate range: excluding 0050, 0100)	●	●	●	●	●
H8	Push-in (φ8), resin body	●	●	●	●	●
8A	Rc1/4, stainless steel body	●	●	●	●	●
UF *1	9/16-18UNF, stainless steel body	●	●	●	●	●

⑥ Input signal	
0	Analog 0 to 10 VDC
1	Analog 0 to 5 VDC
2	Analog 4 to 20 mADC
P	Parallel 10 bit

⑦ Output specifications	
AN	1 to 5 V analog error (NPN)
AP	1 to 5 V analog error (PNP)
SN	Switch (NPN), error (NPN)
SP	Switch (PNP), error (PNP)

⑧ Display direction	
Blank	Forward direction
R	Reverse direction

⑨ Cable	
Blank	None
1	1 m
3	3 m

② Bracket	
Blank	None
B	With bracket

① Traceability	
Blank	None
T	Traceability certification with series variation diagram and company certification
K	With company certification

■ For hydrogen, helium

How to order

**FCM** - **0002** **H2** - **8A** **0** **AN** **R** **1** **B** **T**

Model No.

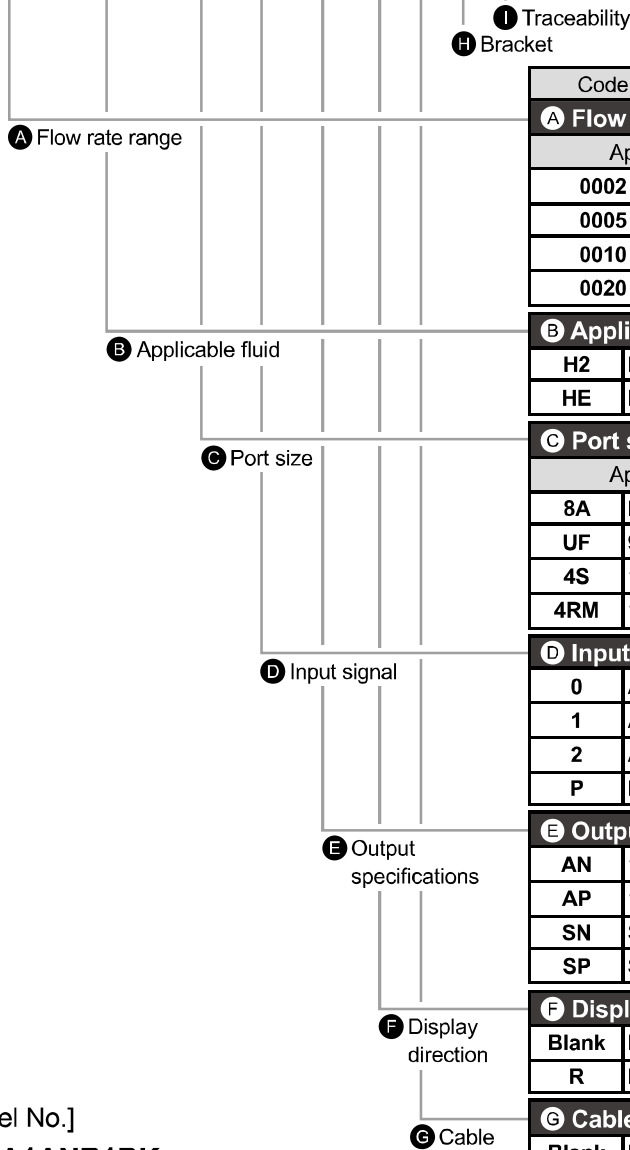

[Example of model No.]

**FCM-0002H2-8A1ANR1BK**

- ③ Flow rate range : 0 to 2 l/min
- ④ Applicable fluid : Hydrogen
- ⑤ Port size : Rc1/4
- ⑥ Input signal : Analog 0 to 5 VDC
- ⑦ Output specifications : 1 to 5 V analog, error (NPN)
- ⑧ Display direction : Reverse direction
- ⑨ Cable : 1 m
- ② Bracket : With bracket
- ① Traceability : With company certification

Discrete option model No.

**FCM** - **AC1**

Code	Content
AC1	Analog 9-conductor, 1 m cable
AC3	Analog 9-conductor, 3 m cable
PC1	Parallel 15-conductor, 1 m cable
PC3	Parallel 15-conductor, 3 m cable
LB1	Bracket

Code	Content		
<b>A Flow rate range</b>			
	Applicable fluid	H2	HE
0002	0 to 2 l/min	●	●
0005	0 to 5 l/min	●	●
0010	0 to 10 l/min	●	●
0020	0 to 20 l/min	●	●
<b>B Applicable fluid</b>			
H2	Hydrogen		
HE	Helium		
<b>C Port size</b>			
	Applicable fluid	H2	HE
8A	Rc1/4	●	●
UF	9/16-18UNF	●	●
4S	1/4" double barbed fitting	●	●
4RM	1/4" JXR male fitting	●	●
<b>D Input signal</b>			
0	Analog 0 to 10 VDC		
1	Analog 0 to 5 VDC		
2	Analog 4 to 20 mADC		
P	Parallel 10 bit		
<b>E Output specifications</b>			
AN	1 to 5 V analog error (NPN)		
AP	1 to 5 V analog error (PNP)		
SN	Switch (NPN), error (NPN)		
SP	Switch (PNP), error (PNP)		
<b>F Display direction</b>			
Blank	Forward direction		
R	Reverse direction		
<b>G Cable</b>			
Blank	None		
1	1 m		
3	3 m		
<b>H Bracket</b>			
Blank	None		
B	With bracket		
<b>I Traceability</b>			
Blank	None		
T	Traceability certification with series variation diagram and company certification		
K	With company certification		

F.R.L
F (Filtr)
R (Reg)
L (Lub)
PresSW
Shutoff
SlowStart
FmResistFR
Oil-ProhR
MedPresFR
No Cu/PTFE FRL
Outdrs FR
F.R.L (Related)
CompFRL
LgFRL
PrecsR
VacF/R
Clean FR
ElecPneuR
AirBoost
SpdContr
SilIncr
CheckV/other
Jnt/tube
AirUnt
PresCompn
Mech/ElecPresSw
ContactSW
AirSens
PresSW Cool
AirFloSens/Contr
WaterPtSens
TotAirSys (Total Air)
TotAirSys (Gamma)
RefrDry
DesicDry
HiPolymDry
MainFiltr
Dischrg etc
Ending

F.R.L
F (Filtr)
R (Reg)
L (Lub)
PresSW
Shutoff
SlowStart
FlmResistFR
Oil-ProhR
MedPresFR
No Cu/ PTFE FRL
Outdrs FR
F.R.L (Related)
CompFRL
LgFRL
PrecsR
VacF/R
Clean FR
ElecPneuR
AirBoost
SpdContr
Silncr
CheckV/ other
Jnt/tube
AirUnt
PrecsCompn
Mech/ ElecPresSw
ContactSW
AirSens
PresSW Cool
AirFloSens/ Contr
WaterRtSens
TotAirSys (Total Air)
TotAirSys (Gamma)
RefrDry
DesicDry
HiPolymDry
MainFiltr
Dischrg etc
Ending

## Dimensions

Body material: Resin, port size:  $\phi 6$ ,  $\phi 8$

● FCM-□-H8/H6□

For FCM-□-□R□, display direction is reversed.

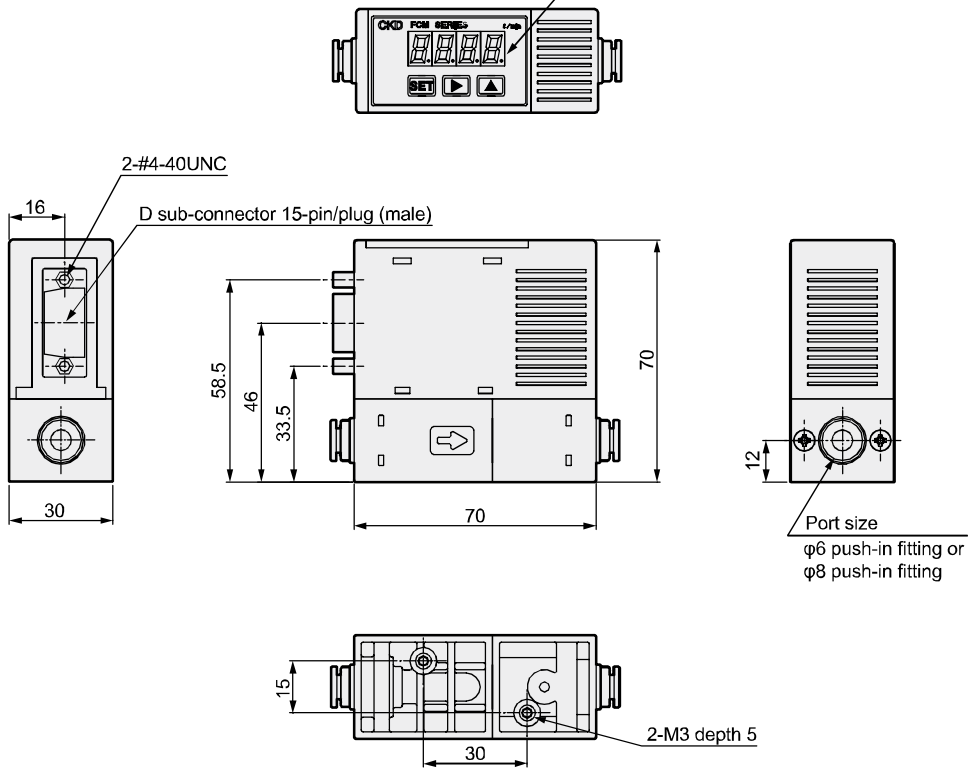

Body material: Stainless steel, Port size: Rc1/4, 9/16-18UNF

● FCM-□-8A/UF

For FCM-□-□R□, display direction is reversed.

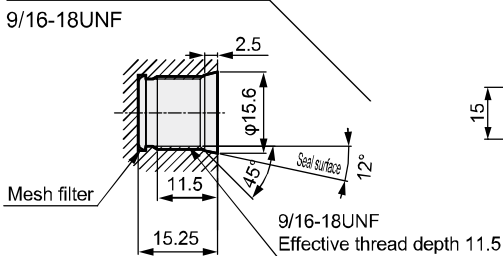
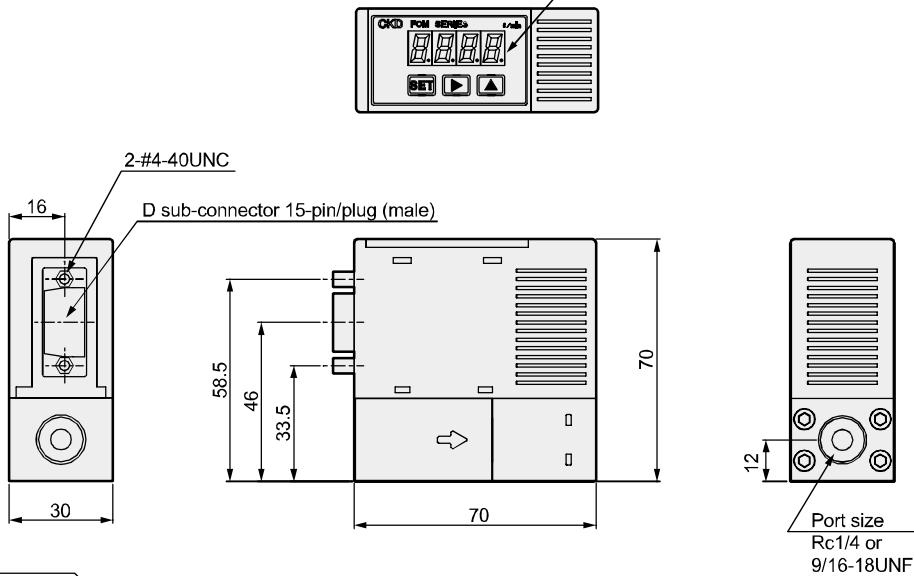



### Dimensions

Port size: 1/4" double barbed fitting

● FCM-□-4S

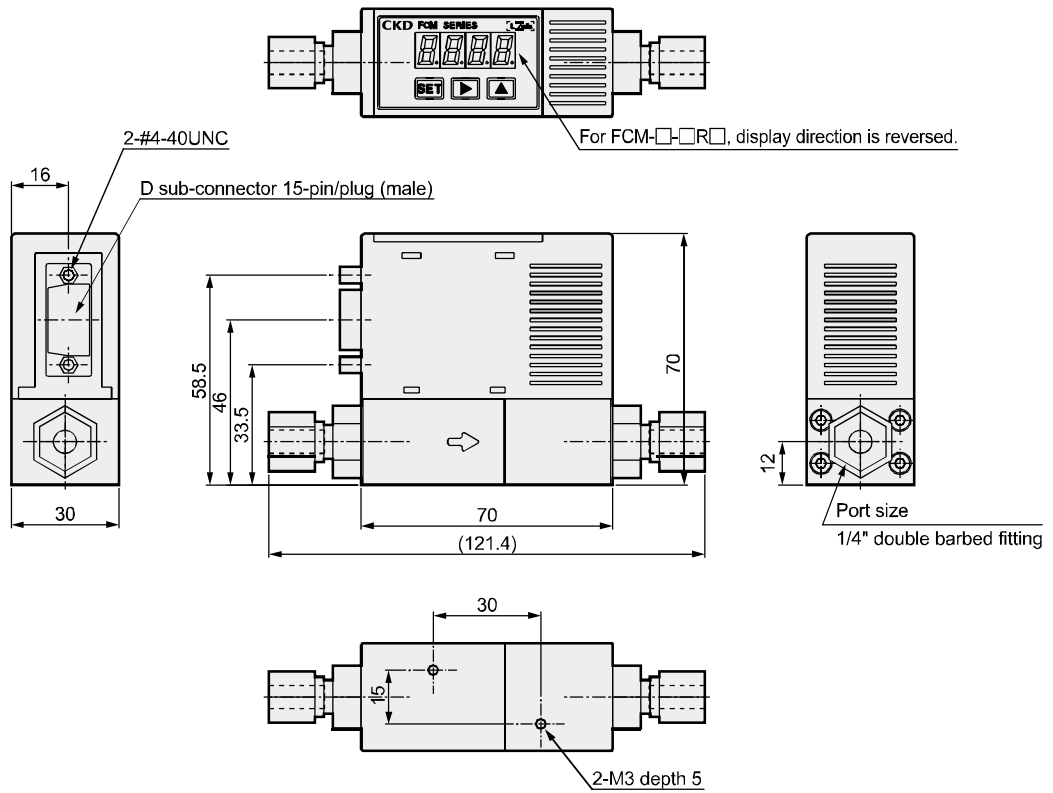

Port size: 1/4" JXR male fitting

● FCM-□-4RM

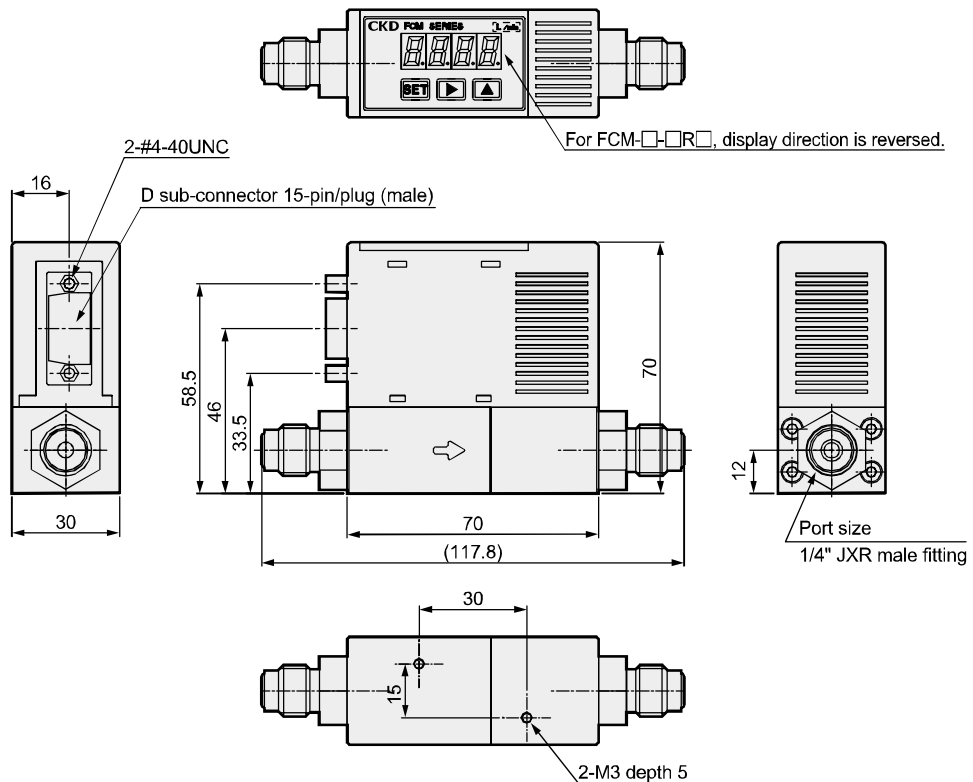

F.R.L
F (Filtr)
R (Reg)
L (Lub)
PresSW
Shutoff
SlowStart
FmResistFR
Oil-ProhR
MedPresFR
No Cu/ PTFE FRL
Outdrs FR
F.R.L (Related)
CompFRL
LgFRL
PrecsR
VacF/R
Clean FR
ElecPneuR
AirBoost
SpdContr
Silncr
CheckV/ other
Jnt/tube
AirUnt
PresCompn
Mech/ ElecPresSW
ContactSW
AirSens
PresSW Cool
AirFloSens/ Contr
WaterPtSens
TotAirSys (Total Air)
TotAirSys (Gamma)
RefrDry
DesicDry
HiPolymDry
MainFiltr
Dischrg etc
Ending

## F.R.L Dedicated bracket (floor mounted)

F (Filtr) Discrete model No.: FCM-LB1

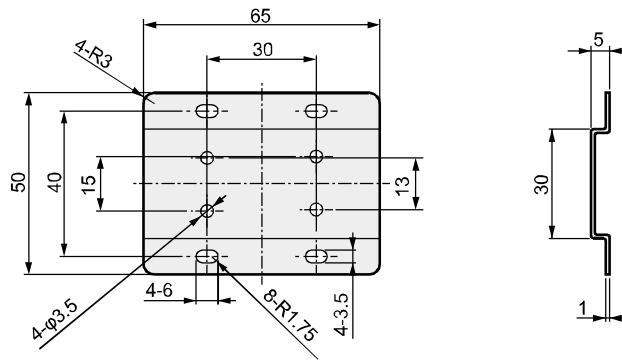

Material: Steel  
Weight: 28g

## Cable optional dimensions

### ● 9-conductor cable for analog input

Discrete option model No.: FCM-AC1, AC3

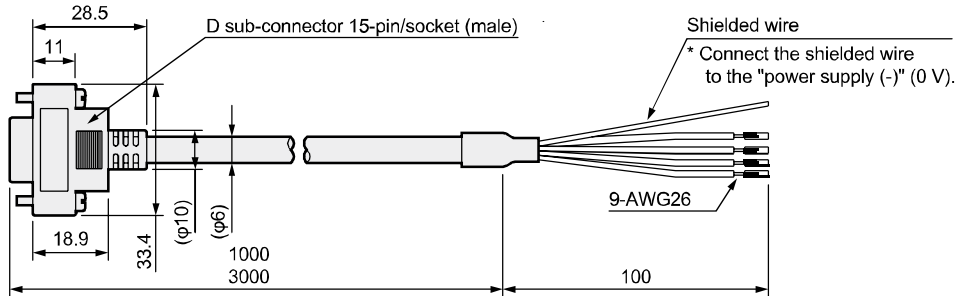

Cable	Weight g
FCM-AC1	68
FCM-AC3	166

D sub-socket pin No.	1	2	3	4	5	6	7	8	9	10	11	12	13	14	15		
Insulator color	Brown	Orange	Yellow	-	Red	-	-	-	-	Gray	White	-	Green	Blue	Black		
Name	Preset input signal		Integration reset signal	Vacant	Power supply +	Vacant	Vacant	Vacant	Vacant	Common	Input signal		Vacant	Analog output	Switch output	Error output	Power supply - (0V)
Input	Bit 1	Bit 2			+24 VDC						0 to 10 VDC	0 to 5 VDC	4 to 20 mADC	Vacant	1 to 5 VDC	NPN or PNP output	

Note: The No. 10 pin common is the common for the preset input and integration reset signal (pin No. 1 to 3).

### ● 15-conductor cable for parallel input

Discrete option model No.: FCM-PC1, PC3

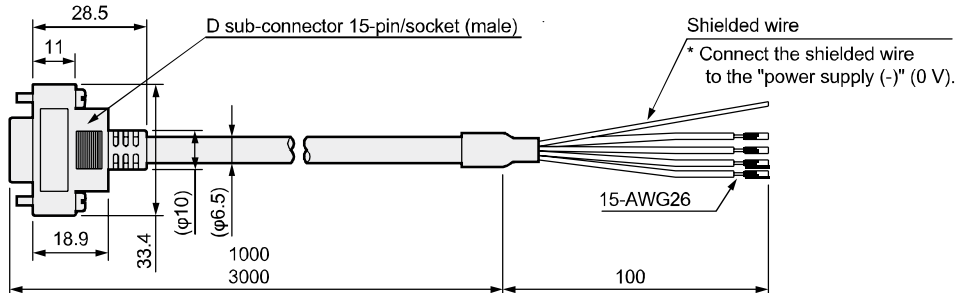

Cable	Weight g
FCM-PC1	82
FCM-PC3	205

D sub-socket pin No.	1	2	3	4	5	6	7	8	9	10	11	12	13	14	15	
Insulator color	Brown	Orange	Yellow	Purple	Red	Light blue	Pink	White/black line	Red/black line	Gray	White	Green/black line	Green	Blue	Black	
Name	Parallel input signal				Power supply +	Parallel input signal				Common	Parallel input signal		Analog output	Switch output	Error output	Power supply - (0V)
Input	Bit 1	Bit 2	Bit 3	Bit 4	+24 VDC	Bit 5	Bit 6	Bit 7	Bit 8		Bit 9	Bit 10	1 to 5 VDC	NPN or PNP output	NPN or PNP output	

Note: The No. 10 pin common is the common for the parallel input signal (pin No. 1 to 4, 6 to 9, 11, 12).

## Wiring method

### Example of internal circuit and load connection Parallel input

**CAUTION** Take care to prevent incorrect wiring.

FCM-□-□0/1/2 AN□  
(Analog input, analog output + error output NPN output)

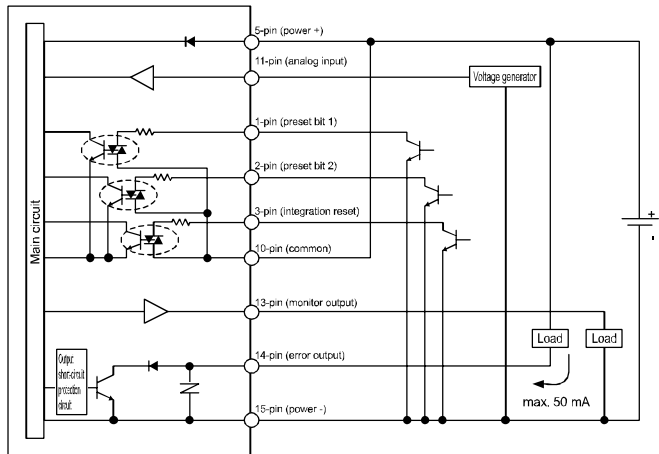

FCM-□-□0/1/2 AP□  
(Analog input, analog output + error output PNP output)

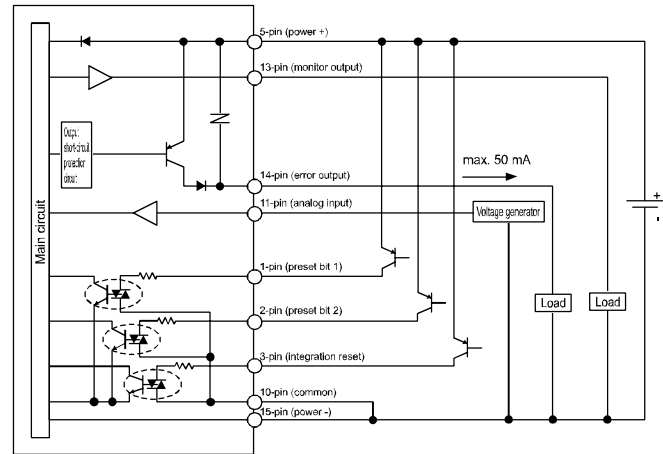

FCM-□-□0/1/2 SN□  
(Analog input, switch output + error output NPN output)

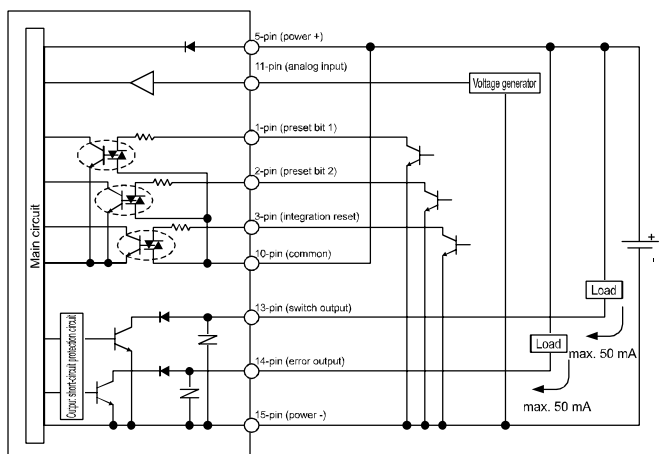

FCM-□-□0/1/2 SP□  
(Analog input, switch output + error output PNP output)

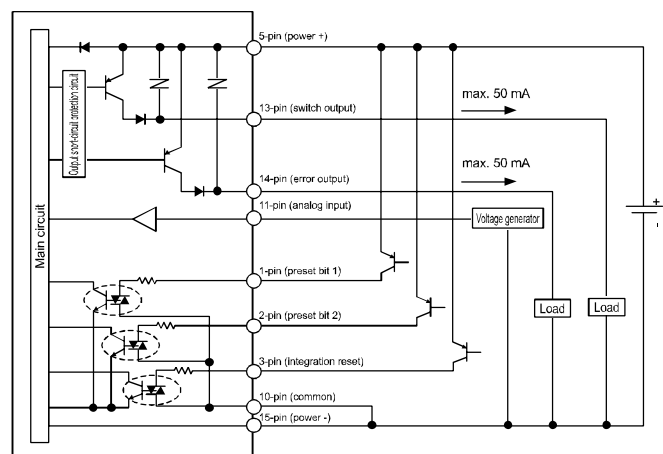

■ Connector pin array (product body side)  
[Analog input]

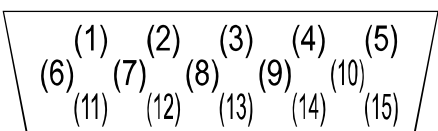

The analog input  
(4), (6), (7), (8), (9) and (12) do not have pins.

F.R.L
F (Filtr)
R (Reg)
L (Lub)
PresSW
Shutoff
SlowStart
FmResistFR
Oil-ProhR
MedPresFR
No Cu/ PTFE FRL
Outdrs FR
F.R.L (Related)
CompFRL
LgFRL
PrecsR
VacF/R
Clean FR
ElecPneuR
AirBoost
SpdContr
Silncr
CheckV/ other
Jnt/tube
AirUnt
PresCompn
Mech/ ElecPresSw
ContactSW
AirSens
PresSW Cool
AirFloSens/ Contr
WaterPtSens
TotAirSys (Total Air)
TotAirSys (Gamma)
RefrDry
DesicDry
HiPolymDry
MainFiltr
Dischrg etc
Ending

## Example of internal circuit and load connection Parallel input

**CAUTION** Take care to prevent incorrect wiring.

FCM-□-□ PAN□  
(Parallel input, analog output + error output NPN output)

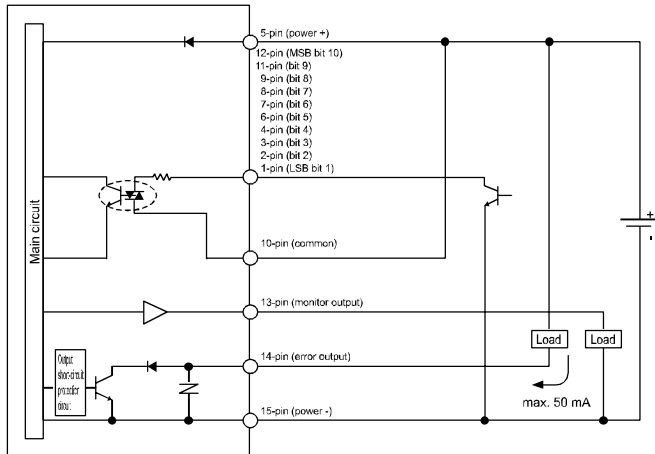

FCM-□-□ PAP□  
(Parallel input, analog output + error output PNP output)

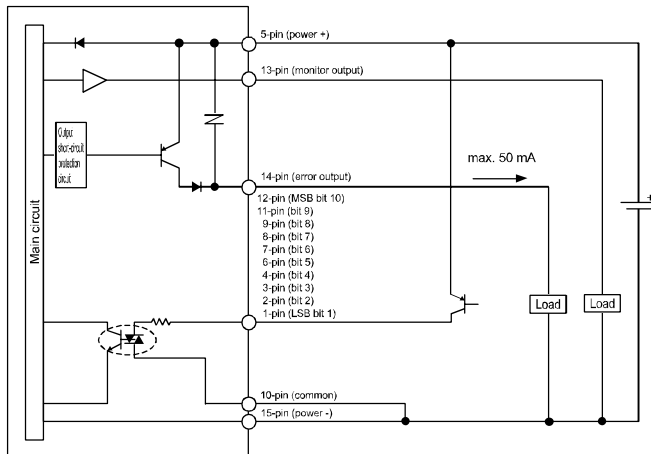

FCM-□-□ PSN□  
(Parallel input, switch output + error output NPN output)

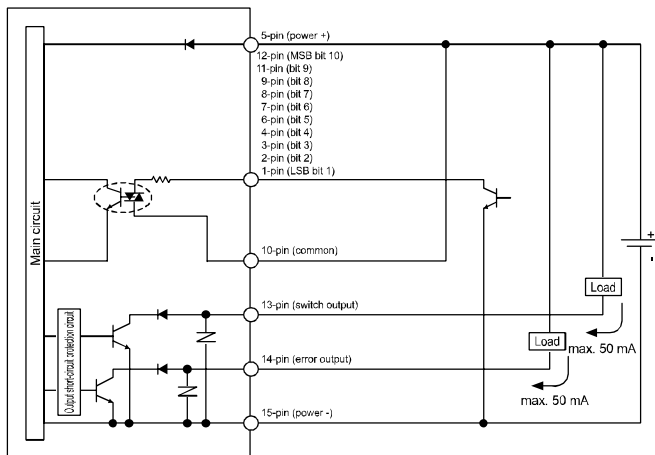

FCM-□-□ PSP□  
(Parallel input, switch output + error output PNP output)

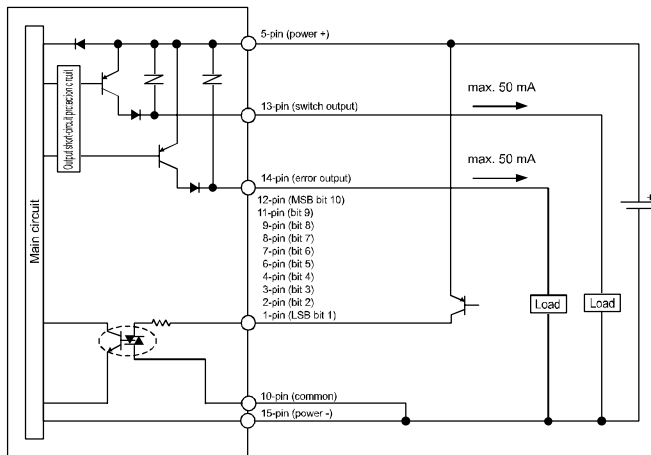

■ Connector pin array (product body side)  
[Parallel input]

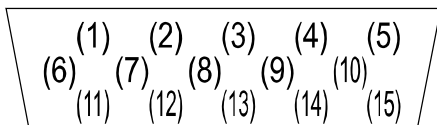



## Compact flow rate controller Functions of FCM Series

### Functions

Function	Content	Function compatible model				Operating method
		Analog input		Parallel input		
		Analog output	Switch output	Analog output	Switch output	
Direct memory function	Target value can be entered by key. Control flow rate can be controlled freely by operation key on the product even if there is no external input signal.	○	○	○	○	P1347,1348 P1358
Preset input function	By specifying 4 arbitrary flow rates, the flow rate can be controlled with an external 2-bit input signal (signal from PLC, etc.).	○	○			P1349 P1358
Analog input function	Flow rate can be controlled with an analog input signal.	○	○			P1351 P1358
Parallel input function	Flow rate can be controlled with a parallel 10-bit (signal from PLC, etc.). Expensive input-output devices such as D/A converters are not required.			○	○	P1352 P1357
Integrating functions	Integrates the flow rate. As well as integrating flow display, it has the following functions. <ul style="list-style-type: none"> <li>· Closes the solenoid valve when the value reaches the set integrating flow</li> <li>· Integrated pulse function (switch output only) *1</li> <li>· Turns the switch ON when the value reaches the set integrating flow (switch output only) *1</li> </ul> How to reset the integrated value <ul style="list-style-type: none"> <li>· Analog input: External input, button operation</li> <li>· Parallel input: Button operation only</li> </ul>	○ (*1)	○	○ (*1)	○	P1353 P1354 P1357 P1359 P1360
Switch output functions	The switch functions below can be selected <ul style="list-style-type: none"> <li>· (1) Tolerance mode: Turns the switch ON when the value is within tolerance against the control target value (arbitrary setting)</li> <li>· (2) Designated range mode: Turns the switch ON when the value is outside the designated flow rate range</li> <li>· (3) Integrated pulse: Outputs the integrated pulse when performing integration</li> <li>· (4) ON at set integration or higher: Turns the switch ON when the value reaches the set integrating flow</li> </ul> <p>[Mode 1: Tolerance mode] [Mode 2: Designated range mode]            H (+ tolerance side) Input signal set value L (- tolerance side)            Output ON OFF</p> <p>[Mode 3: Integrated pulse] [Mode 4: ON at set integration or higher]            ON OFF            Refer to pages 1353 and 1354 for pulse output rate. Set integrated value</p>		○		○	P1354 P1355 P1356 P1359
Input signal zero/span adjustment function	Zero point or span point of input signal can be changed <p>(When disabled) (When enabled)            Control flow rate            100%            0% Input signal 100%            Zero point (L) setting range 0 to 50%            Span point (H) setting range 10 to 100%</p>	○	○			P1359
Zero point adjustment	Adjusts the zero point of flow rate output	○	○	○	○	P1360
Auto-power OFF	Turns the flow rate display OFF if not operated for approx. 1 minute (control does not stop with auto-power OFF function). Turns off unneeded displays to enable energy-saving operation.	○	○	○	○	P1359
Error display function	Capable of displaying error state. As well as error display, it has the following functions. <ul style="list-style-type: none"> <li>· Turns ON error output when an error occurs (applicable only for E01, E02, E05)</li> <li>· Stops control automatically when an error occurs</li> </ul>	○	○	○	○	P1346 P1360
Error auto shut-off	Stops control when an error occurs, fully opens or closes valves, and turns error output ON	○	○	○	○	P1360
Key lock	Disables setting change to avoid incorrect operation	○	○	○	○	P1357
Reset setting	Returns the settings to default (Input signal selection, switch output, input signal zero/span adjustment, auto-power OFF only)	○	○	○	○	P1357

F.R.L
F (Filtr)
R (Reg)
L (Lub)
PresSW
Shutoff
SlowStart
FlnResistFR
Oil-ProhR
MedPresFR
No Cu/ PTFE FRL
Outdrs FR
F.R.L (Related)
CompFRL
LgFRL
PrecsR
VacF/R
Clean FR
ElecPneuR
AirBoost
SpdContr
Silncr
CheckV/ other
Jnt/tube
AirUnt
PresCompn
Mech/ ElecPresSw
ContactSW
AirSens
PresSW Cool
AirFloSens/ Contr
WaterRtsSens
TotAirSys (Total Air)
TotAirSys (Gamma)
RefrDry
DesicDry
HiPolymDry
MainFiltr
Dischrg etc
Ending

## Names and functions of display/operation section

### Output display (Red)

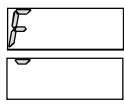

- "F" is displayed when confirming the function setting.
- "." is turned on when switch output is ON. (switch output only)
  - \* Blinks when overcurrent is detected.
  - \* Does not blink at integrated pulse output.
- "E" lights up when error output is ON.
  - \* Blinks when overcurrent is detected.

\* When function settings have upper/lower limits or when high-order digit or low-order digit of integrating flow display is indicated

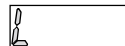

is displayed.

### 3-digit number LED display (green)

- Displays instantaneous flow rate display and function setting details during RUN mode (instantaneous flow rate display).
- \* The setting mode No. and setting details are displayed when displaying details of function settings.
- When setting each data, the values, etc., are displayed.
- Error code No. is displayed at the time of error display.

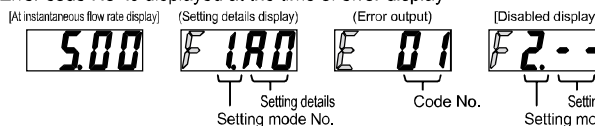

Flow rate 110% or more: Hi  
Flow rate -10% or less: Lo

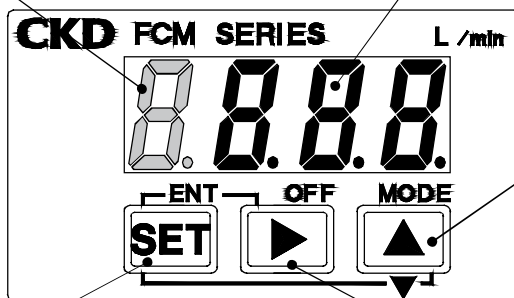

### UP key (MODE key)

- Used to count up values, etc.
- Used to change the setting mode.
- Used to change the settings item.

### SET Key

- Used to confirm the setting mode.
- Used to confirm the setting item.
- Used to change to the integration display.

### Shift key (OFF key)

- It is used to select the digits to the values, etc.
- Used to reset from forced OFF when performing forced OFF (control stop).

### SET + Shift Key (ENT key)

- Used to confirm the value.
- Used to release the key lock.
- Used to reset integration.

### SET + UP Key (DOWN key)

- Used to count down values, etc.
- Used to set the key lock.

### Shift + UP Key

- Used for initialization.

## Error code table

Error display	Cause	Countermeasures	Errors subject to error auto shut-off (*1)
	The power voltage is not within the rating. (Detected at 19.5 VDC or less, detection accuracy $\pm 10\%$ F.S.)	● Check the product's specifications, set the power voltage within the rated range, then turn the power ON again.	○
	The input signal exceeded the rating range. (Detected at input 110% F.S. and over, detection accuracy $\pm 1\%$ F.S.)	● Check the product's input signal, set the input signal within the rated range, then turn the power ON again.	○
	An error occurred during EEPROM reading or writing.	● Contact your CKD branch or dealer.	
	An error occurred during memory reading or writing.	● Contact your CKD branch or dealer.	
	The flow rate did not reach the setting value for approx. 5 secs. or more consecutively. (When the difference between the setting value and control value is $\pm 20\%$ and over, the detection accuracy is $\pm 6\%$ F.S.)	<ul style="list-style-type: none"> <li>● After checking primary pressure, provide pressure within the rating operation differential pressure range, and then turn ON the power supply again. Or it can be reset by releasing after forced OFF (control stop) once.</li> <li>● After checking for leakage from pipes, fittings, or other devices, correctly connect them, and then turn ON the power supply again.</li> <li>● Contact your CKD branch or dealer.</li> </ul>	○
	Sensor output failure has occurred.	● Stop the supply of fluid to the device, set the flow rate setting to zero, and then turn ON the device power supply again. If this error is not resolved, contact your CKD branch or dealer.	○ (*2)
	The switch output's overcurrent protection circuit has functioned.	● After checking whether load current exceeds the rating, correctly connect them, and then turn ON the power supply again.	

Generally, the error resets automatically; however, if it does not do so, turn OFF the power supply, check and correct the cause of the error, and then turn ON the power supply again.

\*1: At shipment, the error auto shut-off was set to OFF (when an error occurs: valve fully closed). Refer to page 1360 for details.

\*2: OFF regardless of the setting of error auto shut-off (when an error occurs: valve fully closed).

## Controlling the flow rate





### (1) When controlling the flow rate using direct memory function

Target value can be entered by key. Control flow rate can be controlled freely by operation display key on the product even if there is no external input signal.

Direct memory function has two operation modes.



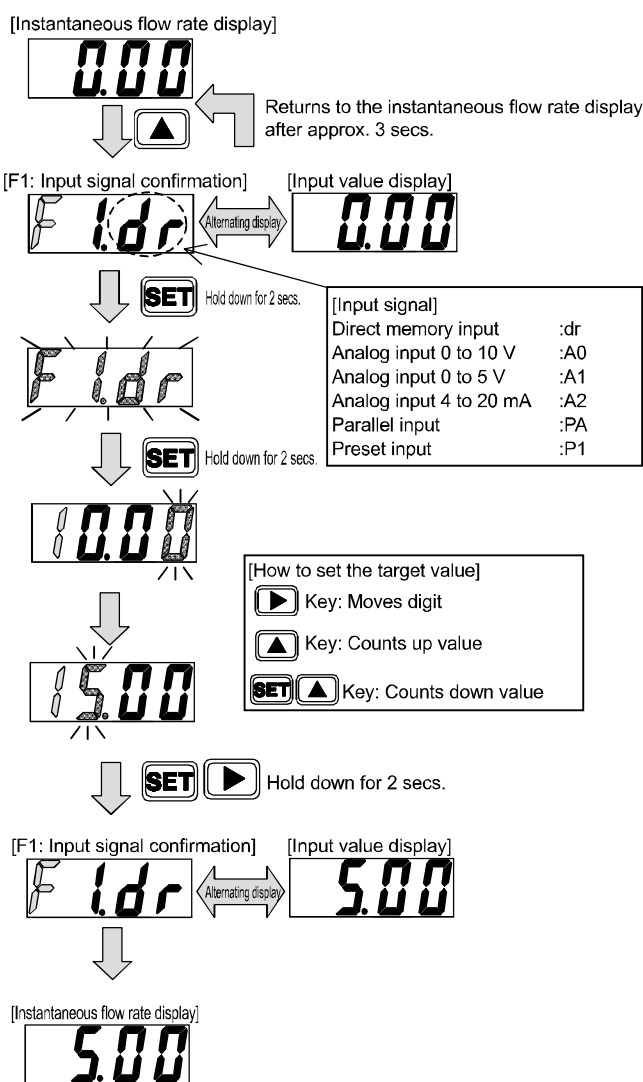
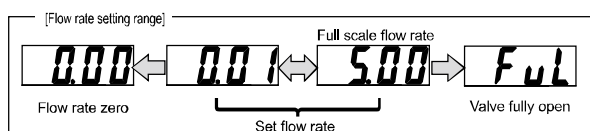

- Direct memory (1): Settings are applied by changing the value. (Even if the value is not confirmed, the flow rate can be varied by changing the value. This function is convenient for fine adjustment of the flow rate. Confirm the setting value after determining the flow rate.)
- Direct memory (2): Applied after the value confirmed. (When not confirming the value, the flow rate is not changed.)

#### [Direct memory (1) operation method]

- (1) Power ON Instantaneous flow rate is displayed.
- (2) By pressing the  key, the screen enters [F1: Input signal confirmation] screen and the present input signal setting state is displayed. The present input signal and input value are alternately displayed. (After 3 secs. have elapsed without pressing the button, the display returns to the instantaneous flow rate display.)
- (3) By holding down the  key for approx. 2 secs., "F1.dr" starts to blink.
- (4) By holding down the  key for approx. 2 secs., the screen enters [Direct memory (1) setting] screen.
- (5) Change the value to change the flow rate. Even if the value is not confirmed, the flow rate can be varied by changing the value.
- (6) By holding down the   keys simultaneously for approx. 2 secs., the value is confirmed. Returns to [F1: Input signal confirmation] screen.
- (7) Returns to the instantaneous flow rate display automatically after approx. 3 secs.



[Input signal]	
Direct memory input	:dr
Analog input 0 to 10 V	:A0
Analog input 0 to 5 V	:A1
Analog input 4 to 20 mA	:A2
Parallel input	:PA
Preset input	:P1

[How to set the target value]	
 Key:	Moves digit
 Key:	Counts up value
  Key:	Counts down value

#### Forced OFF (flow rate zero) method

By holding down the  key for approx. 2 secs. in the flow rate control state (instantaneous flow rate display), the control can be forced to stop (flow rate zero).

By holding down the  key for approx. 2 secs. in the flow rate control stop state (forced OFF), the control can be returned to the flow rate control state.

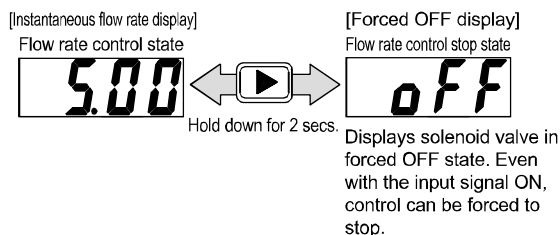

- F.R.L
- F (Filtr)
- R (Reg)
- L (Lub)
- PresSW
- Shutoff
- SlowStart
- FmResistFR
- Oil-ProhR
- MedPresFR
- No Cu/ PTFE FRL
- Outdrs FR
- F.R.L (Related)
- CompFRL
- LgFRL
- PrecsR
- VacF/R
- Clean FR
- ElecPneuR
- AirBoost
- SpdContr
- Silncr
- CheckV/ other
- Jnt/tube
- AirUnt
- PresCompn
- Mech/ ElecPresSw
- ContactSW
- AirSens
- PresSW Cool
- AirFloSens/ Contr
- WaterRtSens
- TotAirSys (Total Air)
- TotAirSys (Gamma)
- RefrDry
- DesicDry
- HiPolymDry
- MainFiltr
- Dischrg etc
- Ending

F.R.L
F (Filtr)
R (Reg)
L (Lub)
PresSW
Shutoff
SlowStart
FmResistFR
Oil-ProhR
MedPresFR
No Cu/ PTFE FRL
Outdrs FR
F.R.L (Related)
CompFRL
LgFRL
PrecsR
VacF/R
Clean FR
ElecPneuR
AirBoost
SpdContr
SiIncr
CheckV/ other
Jnt/tube
AirUnt
PrecsCompn
Mech/ ElecPresSw
ContactSW
AirSens
PresSW Cool
AirFloSens/ Contr
WaterRtSens
TotAirSys (Total Air)
TotAirSys (Gamma)
RefrDry
DesicDry
HiPolymDry
MainFiltr
Dischrg etc
Ending

## Controlling the flow rate

### [Direct memory (2) operation method]

- (1) Power ON Instantaneous flow rate is displayed.
- (2) By pressing the key once, the screen enters [F1: Input signal confirmation] screen and the present input signal setting state is displayed. The present input signal and input value are alternately displayed. (After 3 secs. have elapsed without pressing the button, the display returns to the instantaneous flow rate display.)
- (3) By holding down the key for approx. 2 secs., "F1.dr" starts to blink.
- (4) By holding down the key for approx. 2 secs., the screen enters [Direct memory (2) setting] screen.
- (5) Change the value.  
(When not confirming the value, the flow rate is not changed.)
- (6) By holding down the keys simultaneously for approx. 2 secs., the value is confirmed. Returns to [F1: Input signal confirmation] screen.
- (7) Returns to the instantaneous flow rate display automatically after approx. 3 secs.

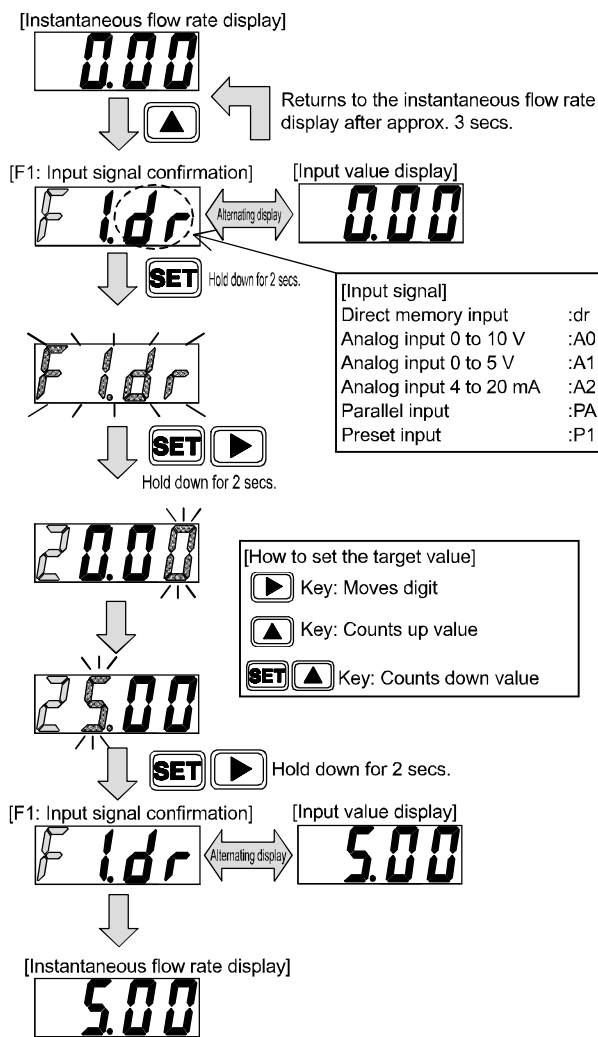

### Forced OFF (flow rate zero) method

- By holding down the key for approx. 2 secs. in the flow rate control state (instantaneous flow rate display), the control can be forced to stop (flow rate zero).
- By holding down the key for approx. 2 secs. in the flow rate control stop state (forced OFF), the control can be returned to the flow rate control state.

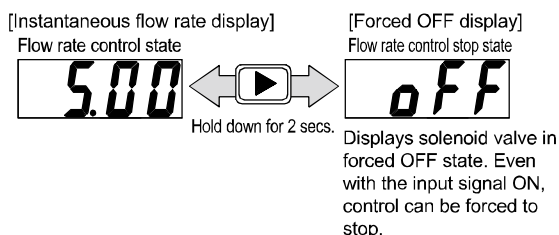

### CAUTION:

- The control is not stopped when direct memory setting is performed. Taking safety into account, if required, conduct it after stopping the control (forced OFF).
- The flow rate control/forced OFF state (setting value) is retained even after the power supply is turned OFF.



## Controlling the flow rate

### (2) When controlling the flow rate using preset input (analog input only)

By specifying 4 arbitrary flow rates, the flow rate can be controlled with an external input signal (2-bit).

Example) To control 0, 1, 2, 5 l/min using preset input, select the preset input in the input setting mode

P1: 0 l/min    P2: 1 l/min  
P3: 2 l/min    P4: 5 l/min

for each setting. When signals are input from a PLC, etc., as indicated in the table at right, the flow rate is controlled to each preset flow rate.

D sub-socket pin No.	2	1	Preset memory number
Cable option insulator color	Orange	Brown	
Input	Bit 2	Bit 1	
Input signal	OFF	OFF	P1
	OFF	ON	P2
	ON	OFF	P3
	ON	ON	P4

#### [Control method using preset input signal]

- Power ON Instantaneous flow rate is displayed.
- By pressing the key once, the screen enters [F1: Input signal confirmation] screen and the present input signal and input value are alternately displayed. (After 3 secs. have elapsed without pressing the button, the display returns to the instantaneous flow rate display.)
- By holding down the key for approx. 2 secs., "F1.dr" starts to blink.
- By pressing the key 2 times, "F1.P1" starts to blink.
- By holding down the key for approx. 2 secs., the screen enters P1 setting confirmation screen.
- Hold down the key for approx. 2 secs. to move to the target input screen, and then enter the target value.
- By holding down the key for approx. 2 secs., the target value is stored in memory, and the screen enters P2 setting confirmation screen. Determine target values through P4 similarly.
- Returns to the instantaneous flow rate display automatically after approx. 3 secs. Flow rate can be controlled using the preset input.

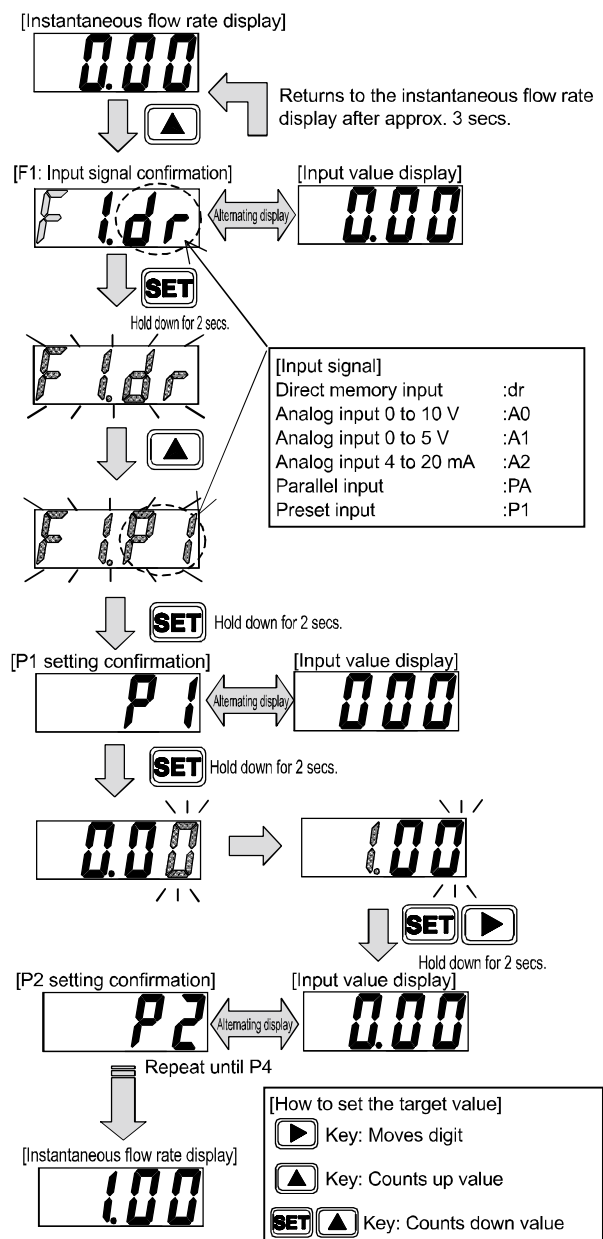

\* If switching bit 1 and bit 2 at the same time, switch within 15 ms.

As an example, note that preset memory may be wrongly set if the time difference is large, such as when switching the preset memory from P2 → P3.

F.R.L
F (Filtr)
R (Reg)
L (Lub)
PresSW
Shutoff
SlowStart
FmResistFR
Oil-ProhR
MedPresFR
No Cu/PTFE FRL
Outdrs FR
F.R.L (Related)
CompFRL
LgFRL
PrecsR
VacF/R
Clean FR
ElecPneuR
AirBoost
SpdContr
Silncr
CheckV/other
Jnt/tube
AirUnt
PresCompn
Mech/ElecPresSw
ContactSW
AirSens
PresSW Cool
AirFloSens/Contr
WaterPtSens
TotAirSys (Total Air)
TotAirSys (Gamma)
RefrDry
DesicDry
HiPolymDry
MainFiltr
Dischrg etc
Ending

- F.R.L
- F (Filtr)
- R (Reg)
- L (Lub)
- PresSW
- Shutoff
- SlowStart
- FlmResistFR
- Oil-ProhR
- MedPresFR
- No Cu/PTFE FRL
- Outdrs FR
- F.R.L (Related)
- CompFRL
- LgFRL
- PrecsR
- VacF/R
- Clean FR
- ElecPneuR
- AirBoost
- SpdContr
- Silncr
- CheckV/other
- Jnt/tube
- AirUnt
- PrecsCompn
- Mech/ElecPresSw
- ContactSW
- AirSens
- PresSW Cool
- AirFloSens/Contr
- WaterRtSens
- TotAirSys (Total Air)
- TotAirSys (Gamma)
- RefrDry
- DesicDry
- HiPolymDry
- MainFiltr
- Dischrg etc
- Ending

## Controlling the flow rate



### (3) Setting change using short cut keys (only when using direct memory and preset input functions)

When using the direct memory function and the preset input function to control the flow rate, the screen can enter the setting value change screen with a single key operation.

**Note:** Enters the screen for changing the set value of the input signal when the shortcut key is pressed.  
 (Example: When controlling the flow rate with the preset input P2, the screen enters the P2 setting value change screen.)  
 Not applicable when controlling the flow rate using analog input or parallel input.

#### [Setting value change method using shortcut]

(1) Power ON Instantaneous flow rate is displayed.  
 (Applicable only when controlling with direct memory function or preset input function)

(2) By holding down the  key for 3 secs., the screen enters the screen for changing the set value of the input signal when the  key is pressed.

(3) Change the value to change the flow rate. Even if the value is not confirmed, the flow rate can be varied by changing the value.

(4) By holding down the   keys simultaneously for approx. 2 secs., the value is confirmed. Returns to [F1: Input signal confirmation] screen.

(5) Returns to the instantaneous flow rate display automatically after approx. 3 secs.

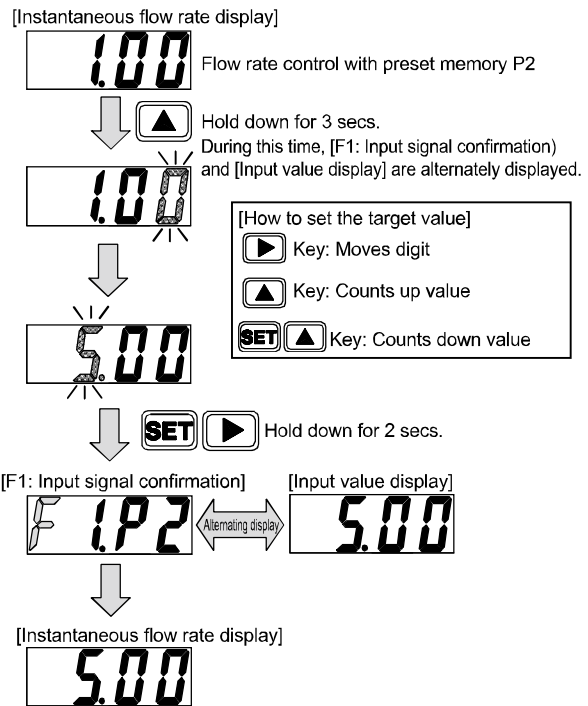





**Note:** When changing settings using shortcut keys, do not switch the preset external input.  
 The setting value may be stored at an incorrect preset number. Because the data is not stored in memory after turning off the power supply without confirming the value, make sure to confirm the value before turning OFF the power supply.

## Controlling the flow rate

### (4) When controlling the flow rate using analog input (analog input only)

Flow rate can be controlled with an analog input signal.

#### [Control method using analog input signal]

- (1) Power ON Instantaneous flow rate is displayed.
- (2) By pressing the  key once, the screen enters [F1: Input signal confirmation] screen and the present input signal setting state is displayed. The present input signal and input value are alternately displayed. (After 3 secs. have elapsed without pressing the button, the display returns to the instantaneous flow rate display.)
- (3) By holding down the  key for approx. 2 secs., "F1.dr" starts to blink.
- (4) By pressing the  key once, "F1.A 0" starts to blink. (Depending on the model No., the number in the  changes.)
- (5) By holding down the  key for approx. 2 secs., the setting is confirmed. Returns to [F1: Input signal confirmation] screen.
- (6) Returns to the instantaneous flow rate display automatically after approx. 3 secs. Flow rate can be controlled using analog input.

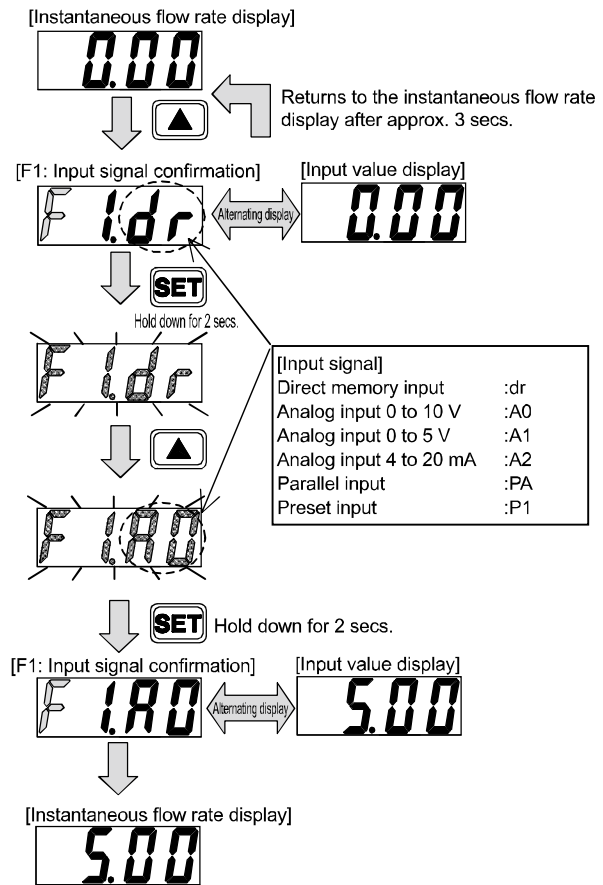

CAUTION: Fully open (FUL) cannot be set with the analog input.

F.R.L
F (Filtr)
R (Reg)
L (Lub)
PresSW
Shutoff
SlowStart
FmResistFR
Oil-ProhR
MedPresFR
No Cu/ PTFE FRL
Outdrs FR
F.R.L (Related)
CompFRL
LgFRL
PrecsR
VacF/R
Clean FR
ElecPneuR
AirBoost
SpdContr
Silncr
CheckV/ other
Jnt/tube
AirUnt
PresCompn
Mech/ ElecPresSw
ContactSW
AirSens
PresSW Cool
AirFloSens/ Contr
WaterPtSens
TotAirSys (Total Air)
TotAirSys (Gamma)
RefrDry
DesicDry
HiPolymDry
MainFiltr
Dischrg etc
Ending

F.R.L  
F (Filtr)  
R (Reg)  
L (Lub)  
PresSW  
Shutoff  
SlowStart  
FlmResistFR  
Oil-ProhrR  
MedPresFR  
No Cu/ PTFE FRL  
Outdrs FR  
F.R.L (Related)  
CompFRL  
LgFRL  
PrecsR  
VacFR/R  
Clean FR  
ElecPneur  
AirBoost  
SpdContr  
Silncr  
CheckV/ other  
Jnt/tube  
AirUnt  
PrecsCompn  
Mech/ ElecPresSw  
ContactSW  
AirSens  
PresSW Cool  
AirFloSens/ Contr  
WaterRtSens  
TotAirSys (Total Air)  
TotAirSys (Gamma)  
RefrDry  
DesicDry  
HiPolymDry  
MainFiltr  
Dischrg etc  
Ending

## Controlling the flow rate

### (5) When controlling the flow rate using parallel input (parallel input only)

Flow rate can be controlled with a parallel 10-bit (signal from PLC, etc.). Expensive input-output devices such as D/A converters are not required.

The parallel input signal has 10 points, and when converted into a decimal, it is 0-1023. The resolution is approx. 0.1%.

$$\text{Input signal} = \text{Set flow rate} / \text{Full scale flow rate} \times 1023$$

Example) When setting the flow rate to 300 ml/min with full scale flow rate of 500 ml/min





$$300 \text{ (ml/min)} / 500 \text{ (ml/min)} \times 1023 = 613.8 \rightarrow 614$$

When 614 (decimal) is converted into binary, the result is 1001100110. 1 sets the input signal to ON, and 0 sets the input signal to OFF.

(Refer to table below)

D sub-socket pin No.	12	11	9	8	7	6	4	3	2	1
Cable option insulator color	Green (black line)	White	Red (black line)	White (black line)	Pink	Light blue	Purple	Yellow	Orange	Brown
Input	Bit 10 MSB	Bit 9	Bit 8	Bit 7	Bit 6	Bit 5	Bit 4	Bit 3	Bit 2	Bit 1 LSB
Binary [for 614 (decimal)]	1	0	0	1	1	0	0	1	1	0
Input signal	ON	OFF	OFF	ON	ON	OFF	OFF	ON	ON	OFF

#### [Control method using parallel input signal]

- Power ON Instantaneous flow rate is displayed.
- By pressing the  key once, the screen enters [F1: Input signal confirmation] screen and the present input signal setting state is displayed. The present input signal and input value are alternately displayed. (After 3 secs. have elapsed without pressing the button, the display returns to the instantaneous flow rate display.)
- By holding down the  key for approx. 2 secs., "F1.dr" starts to blink.
- By pressing the  key 1 time, "F1.PA" starts to blink.
- By holding down the  key for approx. 2 secs., the setting is confirmed. Returns to [F1: Input signal confirmation] screen.
- Returns to the instantaneous flow rate display automatically after approx. 3 secs. Flow rate can be controlled using parallel input.

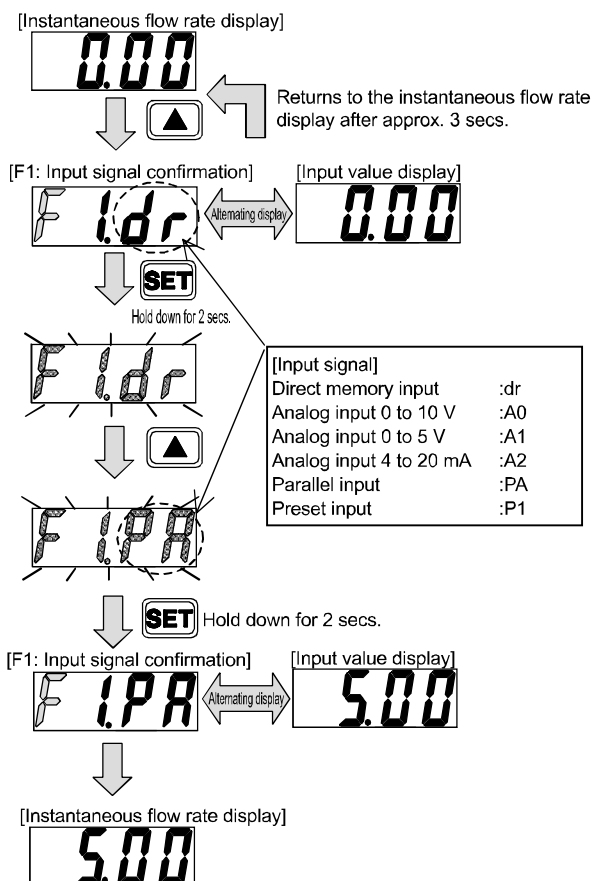

CAUTION: Fully open (FUL) cannot be set with the parallel input.

#### [Reference]

If low resolution is acceptable, the number of inputs can be reduced.

Example) If resolution of approx. 2% is acceptable, operation can be performed with input of 6 points (0-63 when converted to decimal). In this case, by shorting the bits 5 to 1 in the table above together to 1 bit (LSB) and turning ON/OFF, the control can be performed with input of 6 points.

## Integrating the flow rate

### (1) How to display integrating flow

Displays flow rate integration. The display range is as in the table below. The integrating flow is a calculated (reference) value.

Model No. FCM-		9500 L9500	0001 L0001	0002 L0002	0005 L0005	0010 L0010	0020	0050	0100
Flow rate display	Display range	0 to 500 mℓ/min	0.00 to 1.00 ℓ/min	0.00 to 2.00 ℓ/min	0.00 to 5.00 ℓ/min	0.0 to 10.0 ℓ/min	0.0 to 20.0 ℓ/min	0.0 to 50.0 ℓ/min	0 to 100 ℓ/min
Integrating functions	Display range	999999 mℓ	9999.99 ℓ	9999.99 ℓ	9999.99 ℓ	99999.9 ℓ	99999.9 ℓ	99999.9 ℓ	999999 ℓ
	Display resolution	1 mℓ	0.01 ℓ	0.01 ℓ	0.01 ℓ	0.1 ℓ	0.1 ℓ	0.1 ℓ	1 ℓ
	Pulse output rate	5 mℓ	0.01 ℓ	0.02 ℓ	0.05 ℓ	0.1 ℓ	0.2 ℓ	0.5 ℓ	1 ℓ

[How to display integration]

- Instantaneous flow rate display**  
Integration starts from the time when the power supply is turned ON. (The integrated value is reset when the power supply is turned OFF.)
- By holding down the **SET** key for approx. 2 secs., the screen enters the integration display screen. To return to the instantaneous flow rate display, hold down **SET** key for approx. 2 secs. Pressing the **▶** key changes the display digit.
- By holding down the **SET ▶** key for approx. 2 secs., the integrated value is reset. For the analog input, integrated value reset is possible from the external input (No. 3 pin). The integrated value is reset when the power supply is turned OFF.

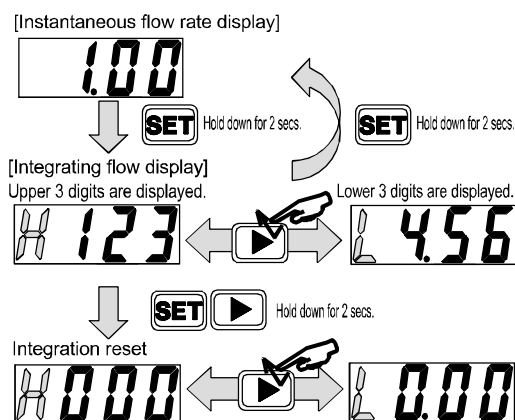

### (2) When closing the solenoid valve when the value reaches the set integrating flow

When the value reaches the set integrating flow, the solenoid valve is closed.  
Ideal for filling processes with a constant flow rate, etc.

[Operating method]

- Instantaneous flow rate display**
- Press the **▲** key 5 times to enter [F5: Integration auto shut-off setting screen]. If the integration auto shut-off setting is enabled, "F5.on" and the present setting value are alternately displayed. (After 3 secs. have elapsed without pressing the button, the display returns to the instantaneous flow rate display.)
- By holding down the **SET** key for approx. 2 secs., "F5.--" starts to blink. When not using the integration auto shut-off, by holding down **SET** key for approx. 2 secs., the display returns to [F5 screen], and after approx. 3 secs., it returns to the instantaneous flow rate display.
- When using the integration auto shut-off, press **▲** key to start "F5.on" blinking, and hold down **SET** key for approx. 2 secs. After setting the higher digit, hold down **SET ▶** key for approx. 2 secs. After setting the lower digit, hold down **SET ▶** key for approx. 2 secs. The display returns to [F5 screen], and after approx. 3 secs., it returns to the instantaneous flow rate display.

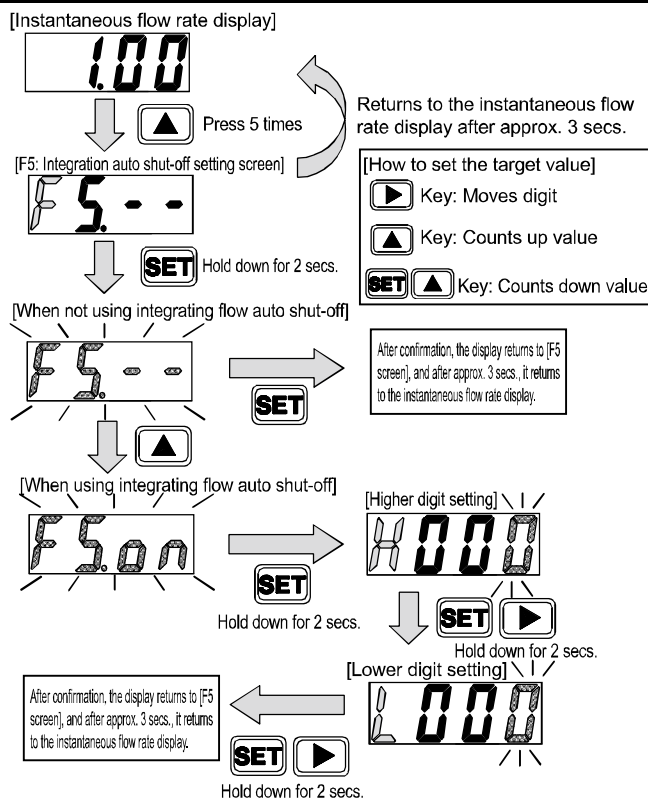

- \* In this mode alone, the integrated value is reset when the input signal goes to zero. (enabled only after auto shut-off)
- \* The solenoid valve is cut off automatically and switch operation is performed when the value matches the integrating flow value.
- \* When the display turns "OFF" by auto shut-off, the switch output light is not turned ON. By resetting the integrated value (with button operation or external input), the display returns to the flow rate display.
- \* Even if the auto shut-off function is disabled at the time of auto shut-off, operation cannot be performed unless the integrated value is reset.
- \* The integrated value is reset at the point when the auto shut-off is turned "ON" and the value is set.

- F.R.L
- F (Filtr)
- R (Reg)
- L (Lub)
- PresSW
- Shutoff
- SlowStart
- FmResistFR
- Oil-ProhR
- MedPresFR
- No Cu/ PTFE FRL
- Outdrs FR
- F.R.L (Related)
- CompFRL
- LgFRL
- PrecsR
- VacF/R
- Clean FR
- ElecPneuR
- AirBoost
- SpdContr
- Silncr
- CheckV/ other
- Jnt/tube
- AirUnt
- PresCompn
- Mech/ ElecPresSw
- ContactSW
- AirSens
- PresSW Cool
- AirFloSens/ Contr
- WaterPtSens
- TotAirSys (Total Air)
- TotAirSys (Gamma)
- RefrDry
- DesicDry
- HiPolymDry
- MainFiltr
- Dischrg etc
- Ending



F.R.L
F (Filtr)
R (Reg)
L (Lub)
PresSW
Shutoff
SlowStart
FlmResistFR
Oil-Prohr
MedPresFR
No Cu/ PTFE FRL
Outdrs FR
F.R.L (Related)
CompFRL
LgFRL
PrecsR
VacF/R
Clean FR
ElecPneuR
AirBoost
SpdContr
SiIncr
CheckV/ other
Jnt/tube
AirUnt
PrecsCompn
Mech/ ElecPresSw
ContactSW
AirSens
PresSW Cool
AirFloSens/ Contr
WaterRtSens
TotAirSys (Total Air)
TotAirSys (Gamma)
RefrDry
DesicDry
HiPolymDry
MainFiltr
Dischrg etc
Ending

## Integrating the flow rate

### (3) When an integrated pulse is outputted (switch output only)

The integrated pulse is output. Refer to the table on page 1353 for pulse rate.

Refer to the wire connection method (page 1342) and example of the internal circuit and load connection (pages 1343, 1344) for the switch output wire connection method.

[Operating method]

- (1) Instantaneous flow rate display
- (2) Press the key 4 times to enter [F4: Switch output setting screen]. If the switch output setting is enabled, "F4.□" and the present setting value are alternately displayed.  
(After 3 secs. have elapsed without pressing the button, the display returns to the instantaneous flow rate display.)
- (3) Hold down the key for 2 secs. to enter the switch output setting mode.
- (4) By pressing the key 3 times, "F4.3" starts to blink. By holding down the key for approx. 2 secs., the integrated pulse output is confirmed. The display returns to [F4 screen], and after approx. 3 secs., it returns to the instantaneous flow rate display.

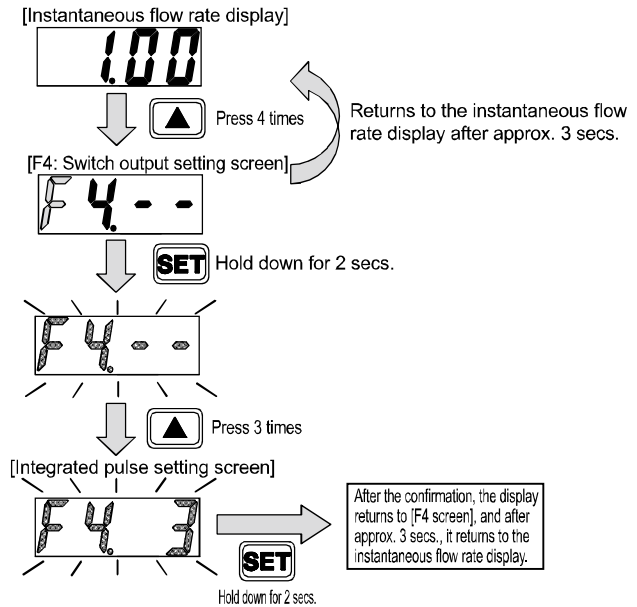

### (4) When switch is ON when the value reaches the set integrating flow (switch output only)

The switch output is turned ON when the value reaches the set integrating flow.

Refer to the wire connection method (page 1342) and example of the internal circuit and load connection (pages 1343, 1344) for the switch output wire connection method.

[Operating method]

- (1) Instantaneous flow rate display
- (2) Press the key 4 times to enter [F4: Switch output setting screen]. If the switch output setting is enabled, "F4.□" and the present setting value are alternately displayed.  
(After 3 secs. have elapsed without pressing the button, the display returns to the instantaneous flow rate display.)
- (3) Hold down the key for 2 secs. to enter the switch output setting mode.
- (4) Press the key once to start "F4.4" blinking, and hold down key for approx. 2 secs. to enter the target value setting screen.  
After setting the higher 3 digits of the target value, hold down key for approx. 2 secs.  
After setting the lower 3 digits of the target value, hold down key for approx. 2 secs. The integrated value is reset immediately after confirmation.
- (5) The display returns to [F4 screen], and after approx. 3 secs., it returns to the instantaneous flow rate display.

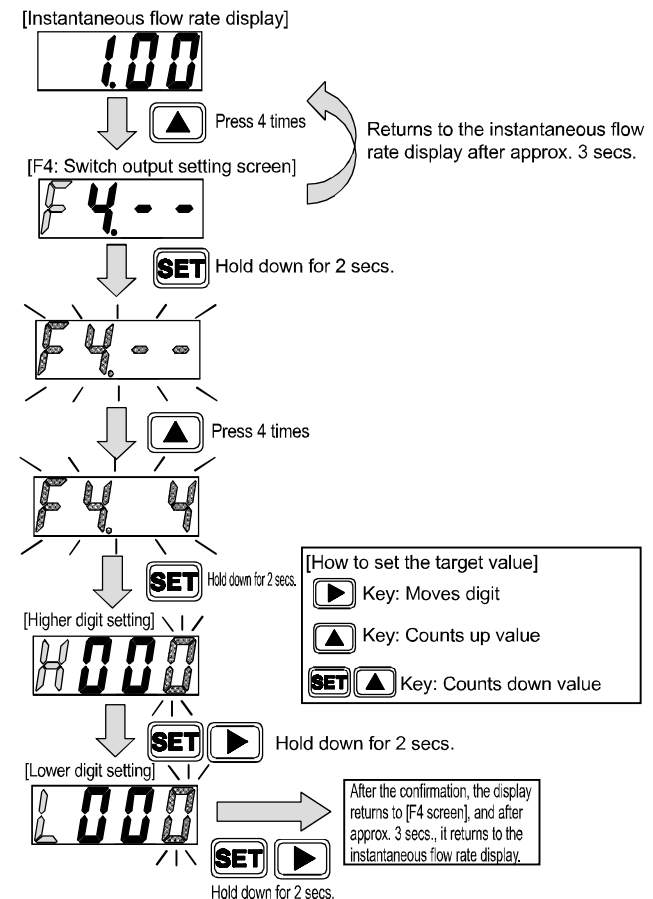



## Using the switch output function (switch output only)

### (1) When using the tolerance mode

Turns the switch output ON when the value is within tolerance against the input signal setting value.  
The tolerance value can be set on both positive and negative sides, with % F.S. (full scale).  
Refer to the wire connection method (page 1342) and example of the internal circuit and load connection (pages 1343, 1344) for the switch output wire connection method.

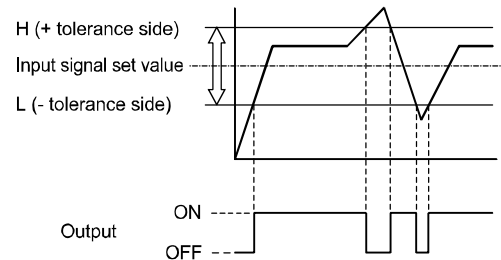

#### [Operating method]

- (1) Instantaneous flow rate display
- (2) Press the key 4 times to enter [F4: Switch output setting screen]. If the switch output setting is enabled, "F4.□" and the present setting value are alternately displayed.  
(After 3 secs. have elapsed without pressing the button, the display returns to the instantaneous flow rate display.)
- (3) Hold down the key for 2 secs. to enter the switch output setting mode.
- (4) Press the key once to start "F4.1" blinking, and hold down key for approx. 2 secs. to enter the target value setting screen.
- (5) After setting the tolerance value (negative side), hold down key for approx. 2 secs.  
Negative side setting range: -50 to 0% F.S.
- (6) After setting the tolerance value (positive side), hold down key for approx. 2 secs.  
Positive side setting range: 0 to 50% F.S.
- (7) The display returns to [F4 screen], and after approx. 3 secs., it returns to the instantaneous flow rate display.

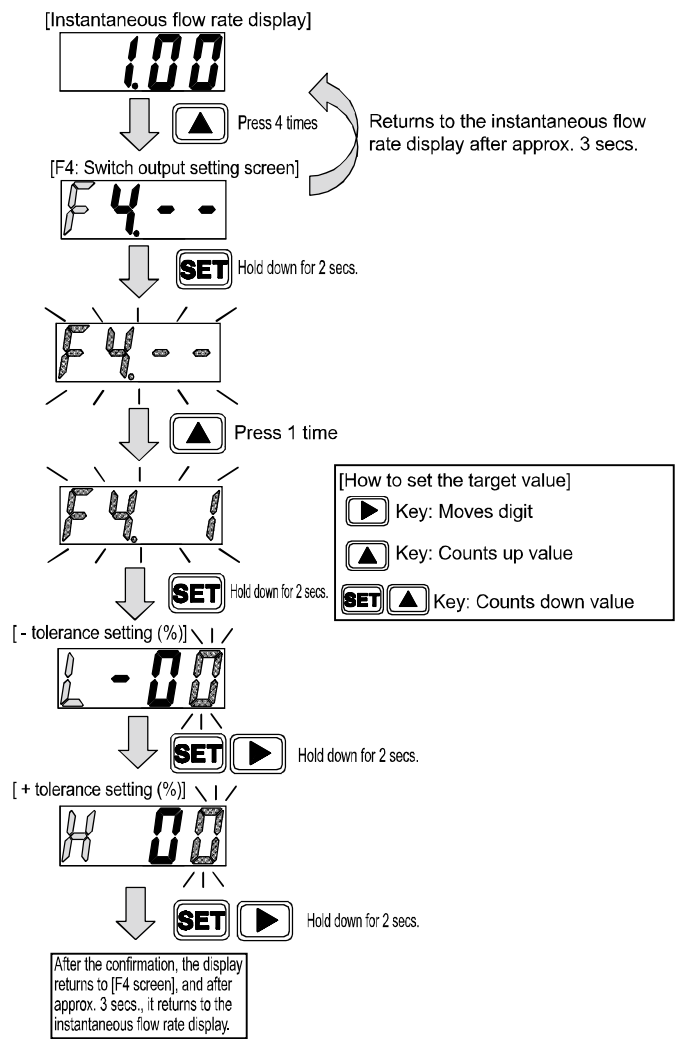

\* When "FUL" is selected as the input signal set value (valve fully open), it operates with the tolerance of the set value selected before. As an example, if the input signal set value is changed from 50 l/min to "FUL" (valve fully open), the switch will be turned ON within the tolerance of 50 l/min.

F.R.L
F (Filtr)
R (Reg)
L (Lub)
PresSW
Shutoff
SlowStart
FmResistFR
Oil-ProhR
MedPresFR
No Cu/PTFE FRL
Outdrs FR
F.R.L (Related)
CompFRL
LgFRL
PrecsR
VacF/R
Clean FR
ElecPneUR
AirBoost
SpdContr
Silncr
CheckV/other
Jnt/tube
AirUnt
PresCompn
Mech/ElecPresSw
ContactSW
AirSens
PresSW Cool
AirFloSens/Contr
WaterPtSens
TotAirSys (Total Air)
TotAirSys (Gamma)
RefrDry
DesicDry
HiPolymDry
MainFiltr
Dischrg etc
Ending

F.R.L
F (Filtr)
R (Reg)
L (Lub)
PresSW
Shutoff
SlowStart
FlmResistFR
Oil-ProhR
MedPresFR
No Cu/ PTFE FRL
Outdrs FR
F.R.L (Related)
CompFRL
LgFRL
PrecsR
VacFR
Clean FR
ElecPneR
AirBoost
SpdContr
Silncr
CheckV/ other
Jnt/tube
AirUnt
PrecsCompn
Mech/ ElecPresSw
ContactSW
AirSens
PresSW Cool
AirFloSens/ Contr
WaterRtSens
TotAirSys (Total Air)
TotAirSys (Gamma)
RefrDry
DesicDry
HiPolymDry
MainFiltr
Dischrg etc
Ending

## Using the switch output function (switch output only)

### (2) When using the designated range mode

The switch output turns ON when the value is outside the designated flow rate range. The upper/lower limits are set regardless of input signal setting value (control target value). Both upper and lower limits can be set, with % F.S. (full scale). Refer to the wire connection method (page 1342) and example of the internal circuit and load connection (pages 1343, 1344) for the switch output wire connection method.

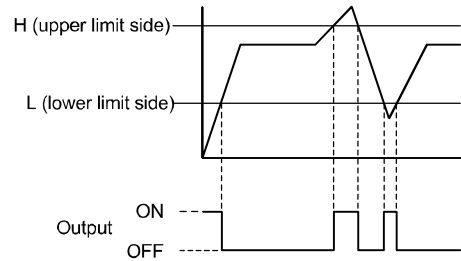

#### [Operating method]

- (1) Instantaneous flow rate display
- (2) Press the key 4 times to enter [F4: Switch output setting screen]. If the switch output setting is enabled, "F4.□" and the present setting value are alternately displayed.  
(After 3 secs. have elapsed without pressing the button, the display returns to the instantaneous flow rate display.)
- (3) Hold down the key for 2 secs. to enter the switch output setting mode.
- (4) Press the key twice to start "F4.2" blinking, and hold down key for approx. 2 secs. to enter the target value setting screen.
- (5) After setting the lower limit, hold down key for approx. 2 secs.  
Lower limit setting range: 0 to 90% F.S.
- (6) After setting the upper limit, hold down key for approx. 2 secs.  
Positive side setting range: 10 to 100% F.S.  
With interval of 10% F.S. or more between the upper limit and lower limit
- (7) The display returns to [F4 screen], and after approx. 3 secs., it returns to the instantaneous flow rate display.

[Instantaneous flow rate display]

1.00

Press 4 times

Returns to the instantaneous flow rate display after approx. 3 secs.

[F4: Switch output setting screen]

F4.-.

Hold down for 2 secs.

F4.-.

Press 2 times

F4.2

Hold down for 2 secs.

[Lower limit setting (%)]

00

Hold down for 2 secs.

[Upper limit setting (%)]

100

Hold down for 2 secs.

After the confirmation, the display returns to [F4 screen], and after approx. 3 secs., it returns to the instantaneous flow rate display.

[How to set the target value]

Key: Moves digit

Key: Counts up value

Key: Counts down value

## Operating methods (list)

- CAUTION:**
- At shipment, the product is in the unlocked state. Put on key lock if required.
  - The key locked/unlocked state is retained after turning the power supply OFF.
  - The control is not stopped during setting of F1: input signal selection and F2: input signal zero/span.
  - Taking safety into account, if required, conduct it after stopping the control (forced OFF).
  - The flow rate control/forced OFF state is retained even after the power supply is turned OFF.

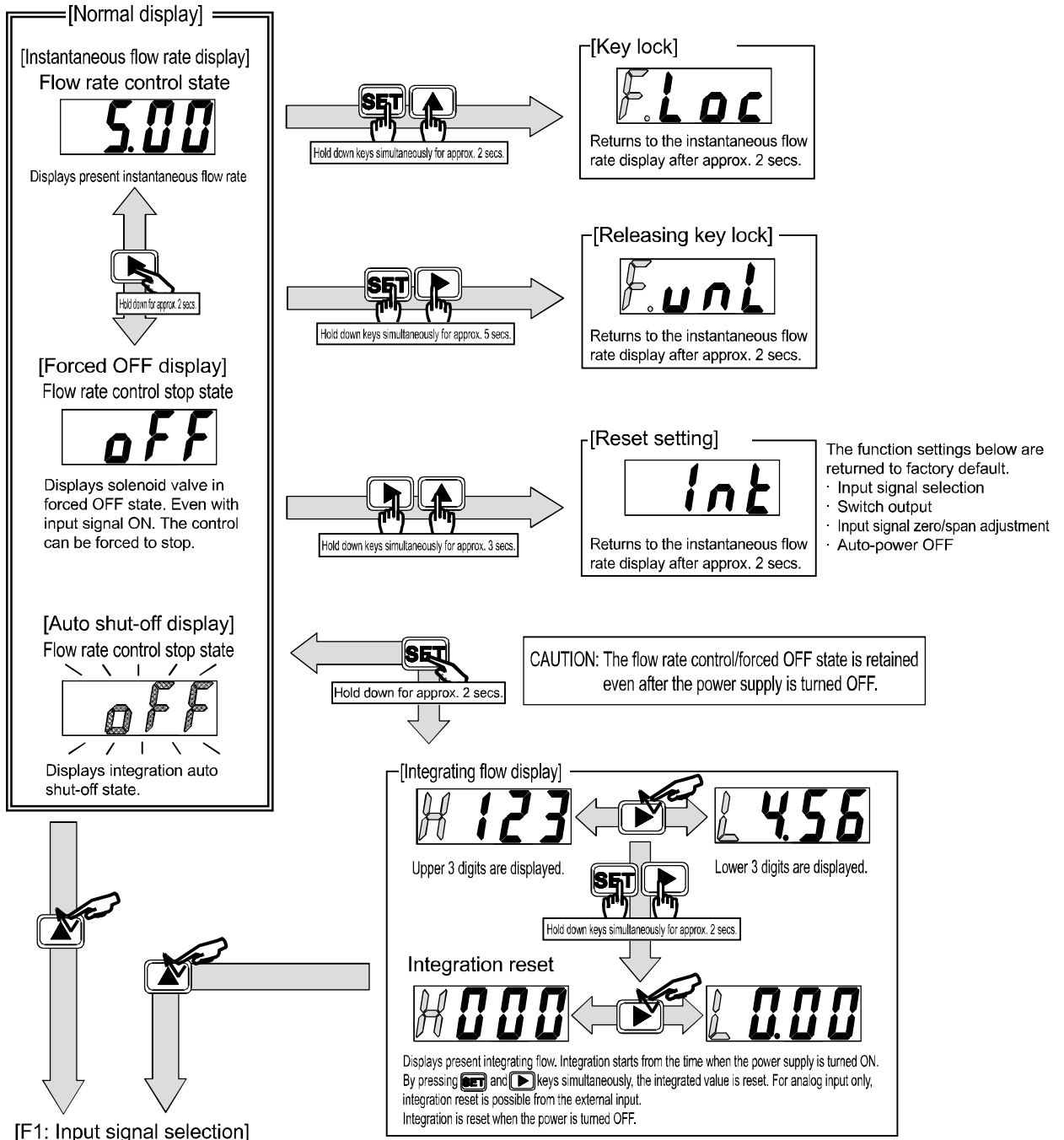

F.R.L
F (Filtr)
R (Reg)
L (Lub)
PresSW
Shutoff
SlowStart
FmResistFR
Oil-ProhR
MedPresFR
No Cu/PTFE FRL
Outdrs FR
F.R.L (Related)
CompFRL
LgFRL
PrecsR
VacF/R
Clean FR
ElecPneuR
AirBoost
SpdContr
Silncr
CheckV/other
Jnt/tube
AirUnt
PresCompn
Mech/ElecPresSw
ContactSW
AirSens
PresSW Cool
AirFloSens/Contr
WaterPtSens
TotAirSys (Total Air)
TotAirSys (Gamma)
RefrDry
DesicDry
HiPolymDry
MainFiltr
Dischrg etc
Ending



### Operating methods (list)

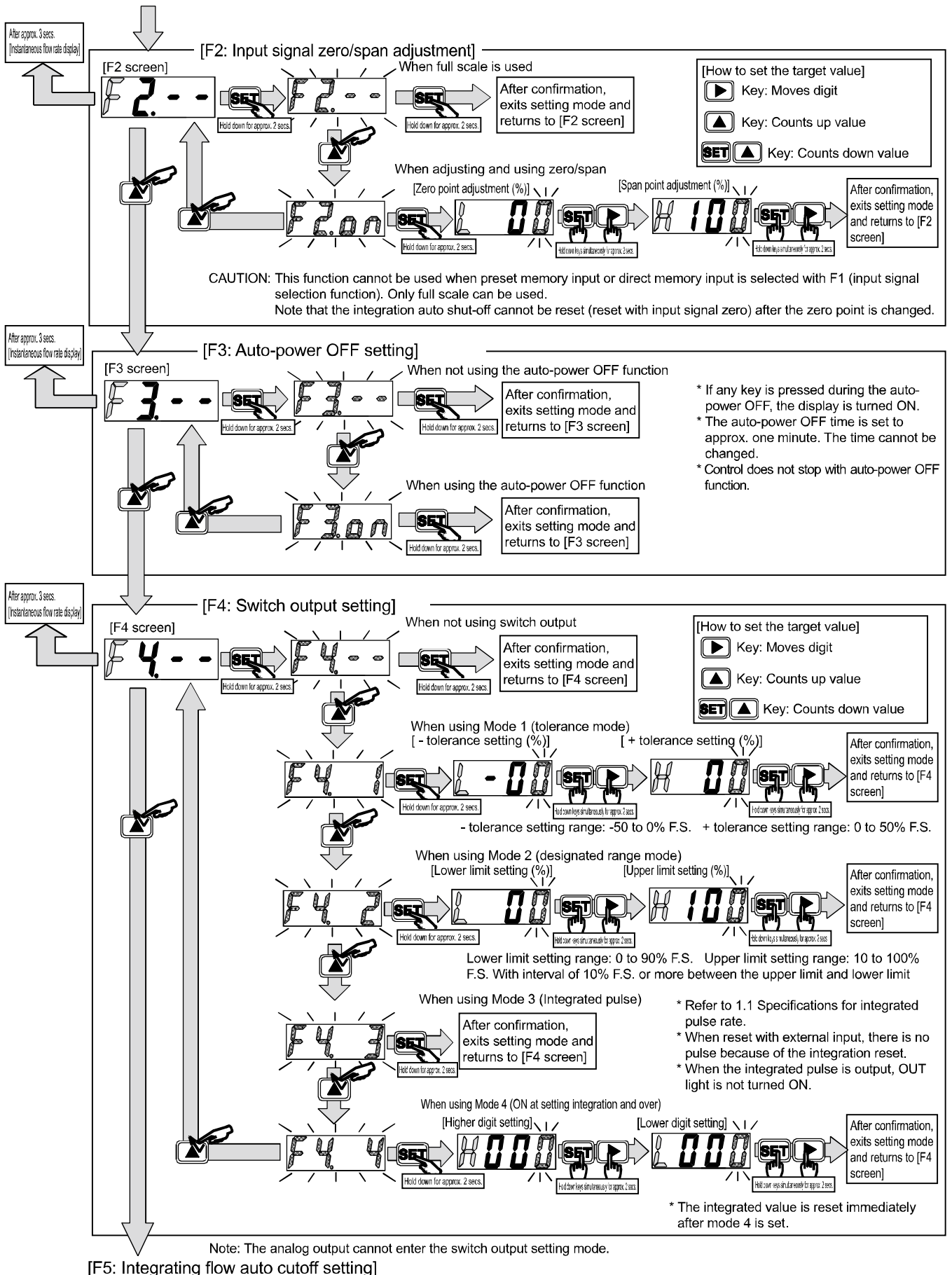

- F.R.L
- F (Filtr)
- R (Reg)
- L (Lub)
- PresSW
- Shutoff
- SlowStart
- FmResistFR
- Oil-ProhR
- MedPresFR
- No Cu/ PTFE FRL
- Outdrs FR
- F.R.L (Related)
- CompFRL
- LgFRL
- PrecsR
- VacF/R
- Clean FR
- ElecPneuR
- AirBoost
- SpdContr
- Silncr
- CheckV/ other
- Jnt/tube
- AirUnt
- PrecsCompn
- Mech/ ElecPresSw
- ContactSW
- AirSens
- PresSW Cool
- AirFloSens/ Contr
- WaterPtSens
- TotAirSys (Total Air)
- TotAirSys (Gamma)
- RefrDry
- DesicDry
- HiPolymDry
- MainFiltr
- Dischrg etc
- Ending

- F.R.L
- F (Filtr)
- R (Reg)
- L (Lub)
- PresSW
- Shutoff
- SlowStart
- FlmResistFR
- Oil-ProhR
- MedPresFR
- No Cu/  
PTFE FRL
- Outdrs FR
- F.R.L  
(Related)
- CompFRL
- LgFRL
- PrecsR
- VacF/R
- Clean FR
- ElecPneuR
- AirBoost
- SpdContr
- Silncr
- CheckV/  
other
- Jnt/tube
- AirUnt
- PrecsCompn
- Mech/  
ElecPresSw
- ContactSW
- AirSens
- PresSW  
Cool
- AirFloSens/  
Contr
- WaterRtSens
- TotAirSys  
(Total Air)
- TotAirSys  
(Gamma)
- RefrDry
- DesicDry
- HiPolymDry
- MainFiltr
- Dischrg  
etc
- Ending

## Operating methods (list)

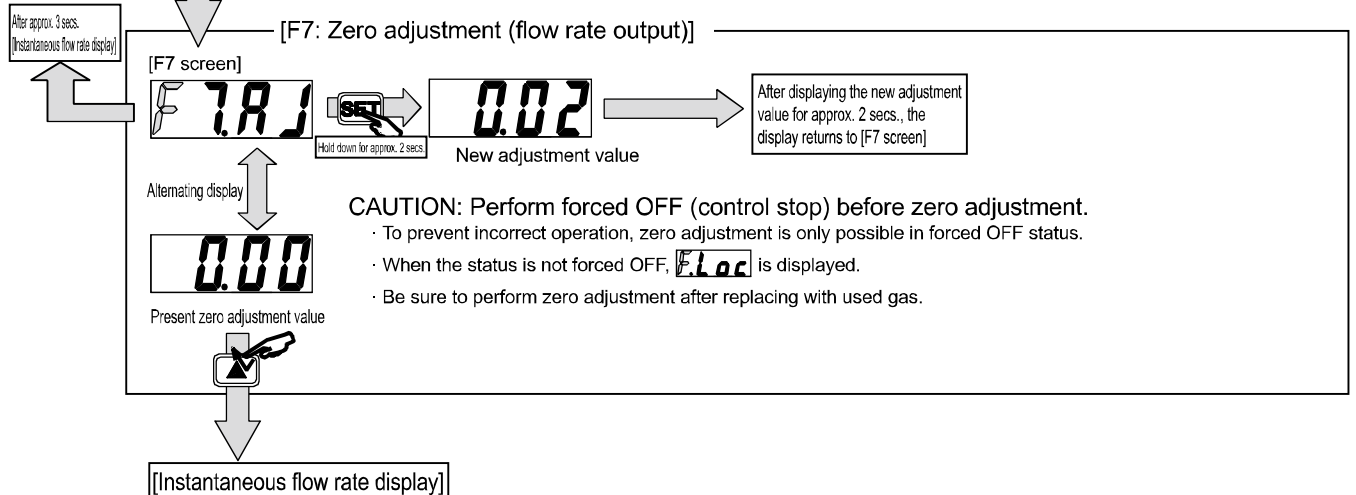
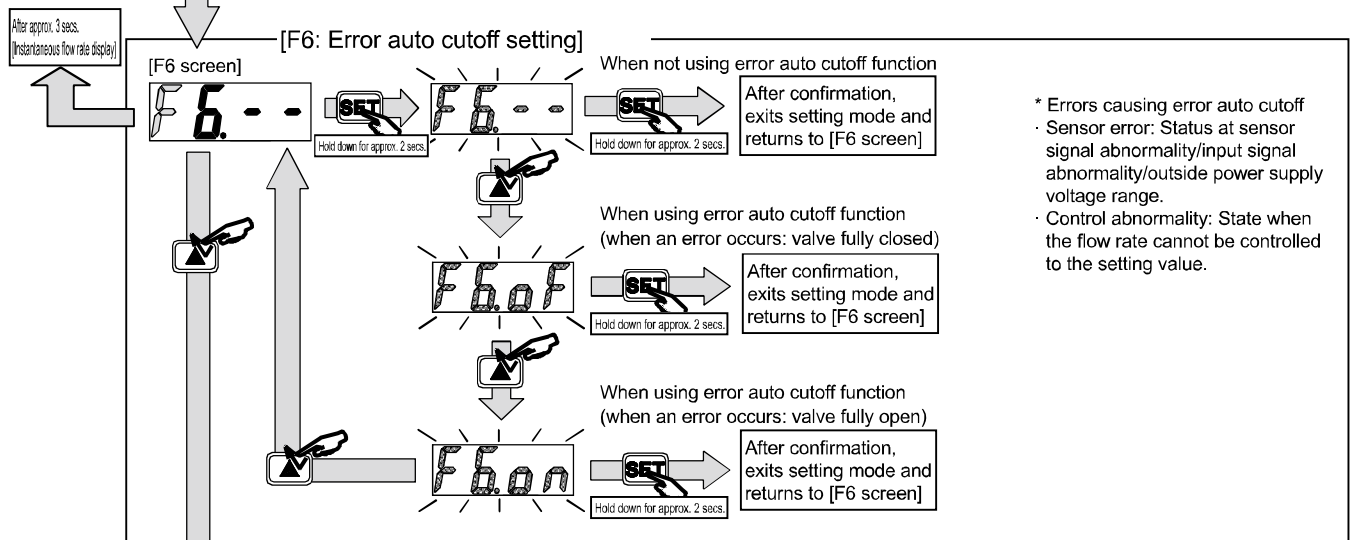
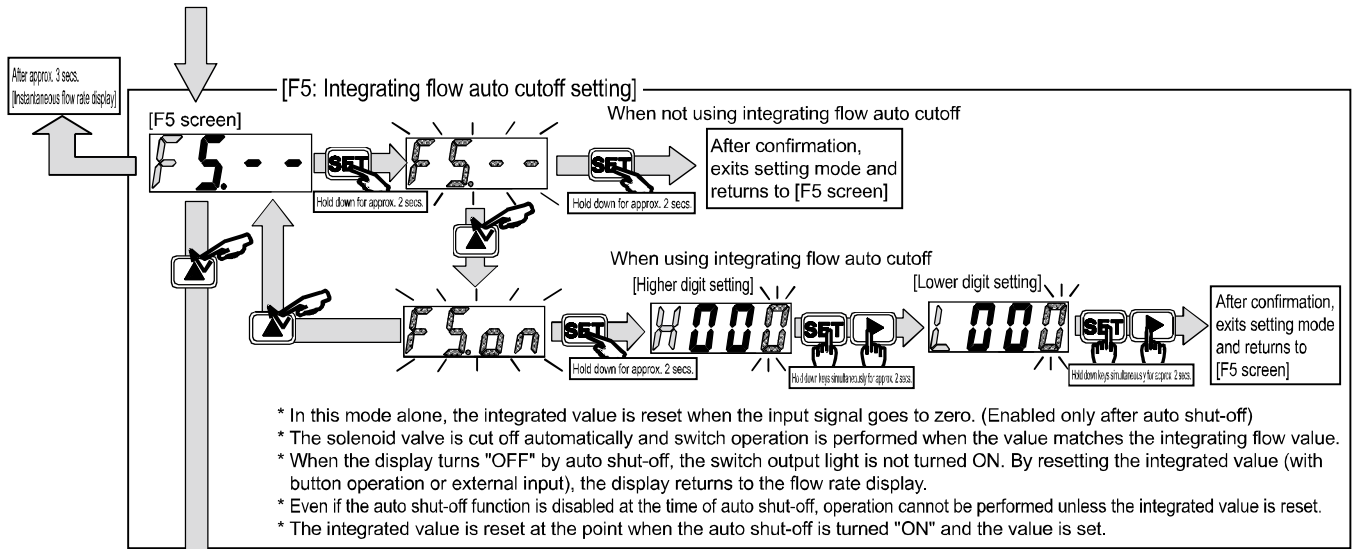



**FCM Glossary**

Applicable to compact flow rate controller FCM.

Term	Explanation
Control range	Calibration range of this product.
Accuracy	Calibration error from CKD reference device. (Conditions: Temperature 25±3°C, power supply voltage 24±0.01 VDC, standard differential pressure, secondary side released to atmosphere)
Repeatability	Calculated from variation (D = Max. - Min.) when flow rate controls of 0% F.S. and 50% F.S. are repeated 20 times continuously in a cycle where the control is sufficiently stabilized. (Reproducibility) = $\pm D/2/FS$ control flow rate x 100[%]
Temperature characteristics	Indicates the fluctuation of the flow rate value according to changes in the ambient / fluid temperatures (reference 25°C) converted per 1°C. Calibration is performed at a temperature of 25°C.
Pressure characteristics	Indicates the fluctuation of the flow rate value according to changes in the working pressure. Calibration is performed at standard differential pressure.
Standard differential pressure	Differential pressure when this product is calibrated. (Secondary side released to atmosphere)
Operating differential pressure	Differential pressure required for normal operation of this product.
Guaranteed proof pressure	Pressure at which the product will not be damaged.
Display resolution	Min. step at which the display changes.
(Integrated) pulse output rate	Integrating flow per pulse when the integrated pulse is output.
LSB	Indicates the min. digit of parallel input.
MSB	Indicates the max. digit of parallel input.
digit	Digit. Min. value of digital display when decimal points are ignored.
AWG	Abbreviation of American Wire Gauge. Standard for cables.

F.R.L

F (Filtr)

R (Reg)

L (Lub)

PresSW

Shutoff

SlowStart

PhiResistFR

Oil-ProhR

MedPresFR

No Cu/ PTFE FRL

Outdrs FR

F.R.L (Related)

CompFRL

LgFRL

PrescR

VacF/R

Clean FR

ElecPneuR

AirBoost

SpdContr

Silncr

CheckV/ other

Jnt/tube

AirUnt

PresCompn

Mech/ ElecPresSw

ContactSW

AirSens

PresSW Cool

AirFloSens/ Contr

WaterPtSens

TotAirSys (Total Air)

TotAirSys (Gamma)

RefrDry

DesicDry

HiPolymDry

MainFiltr

Dischrg etc

Ending



Flow rate controller

# Safety Precautions

Be sure to read this section before use.

F.R.L
F (Filtr)
R (Reg)
L (Lub)
PresSW
Shutoff
SlowStart
FlmResistFR
Oil-ProhR
MedPresFR
No Cu/ PTFE FRL
Outdrs FR
F.R.L (Related)
CompFRL
LgFRL
PrecsR
VacF/R
Clean FR
ElecPneUR
AirBoost
SpdContr
Silncr
CheckV/ other
Jnt/tube
AirUnt
PrecsCompn
Mech/ ElecPresSW
ContactSW
AirSens
PresSW Cool
AirFloSens/ Contr
WaterRtSens
TotAirSys (Total Air)
TotAirSys (Gamma)
RefrDry
DesicDry
HiPolymDry
MainFiltr
Dischrg etc
Ending

## Product-specific cautions: Compact flow rate controller FCM Series

### Design/selection

#### 1. Working fluids

##### **DANGER**

■ Do not feed gas at the explosion limit. There is a risk of explosive accidents.

■ When using this product for hydrogen, be sure to purge with inert gas such as nitrogen or argon before use. Usage without purging with inert gas could result in explosive accidents.

■ For products without oil-free processing in gas-contacting parts, do not feed oxygen gas. Doing so could result in fire. Even for products with oil-free processing, do not use for oxygen gas if the product has been used even once for any other gas.

##### **WARNING**

■ This product cannot be used as a billing meter. Do not use this product for commercial transactions as it is not compliant with the Measurement Act.

■ This product is only for use with the gases indicated in the model No. Do not use fluids other than the applicable fluids, as specifications such as accuracy and control properties cannot be met. In particular, note that if hydrogen gas or helium gas flows into products in this series that is for use with other gases, the sensor safety circuit will activate and the product may not operate. (When the safety circuit is activated, flow rate measurement/control cannot be performed until the power has been turned OFF.)

■ When mixing hydrogen gas or helium gas with a gas other than hydrogen or helium, use caution regarding gas back-flow. If hydrogen gas or helium gas flows into products in this series that is for use with other gases, the sensor safety circuit will activate and the product may not operate. (When the safety circuit is activated, flow rate measurement/control cannot be performed until the power has been turned OFF.) Especially when cutting off the gas, provide individual cutoff valves as in the reference drawing below in order to prevent gas back-flow.

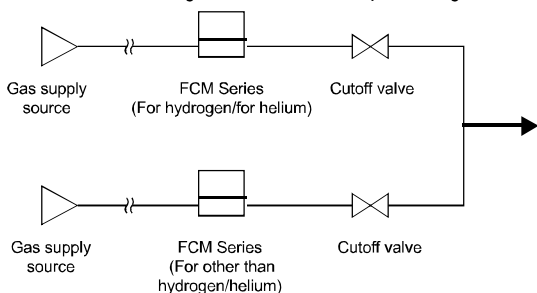

■ Avoid the entry of foreign matter into the product. If foreign matter (dirt, water drops, or oil mist inside the piping, etc.) enters the product, accuracy or control properties may be adversely affected, leading to failure in some cases.

If the entry of foreign matter is possible, install a filter, air dryer, and oil mist filter on the primary side (upstream side) of the product.

- The mesh inside the product rectifies flow in the pipe. Note that it does not filter out foreign matter.
- As compressed air from the compressor contains drainage (water, oil oxides, foreign matter, etc.), install a filter, air dryer, and oil mist filter (micro alescerc) on the primary side (upstream side) of the product.
- When using compressed air, use clean air compliant with JIS B8392-1: 2012 (ISO 8573-1: 2010) [1.1.1 to 1.6.2].

[Recommended circuit]

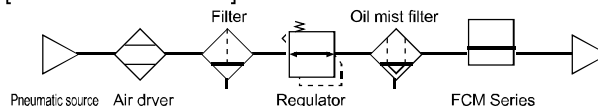

- When using a valve on the primary side of the product, use only valves with oil-prohibited specifications. The product could malfunction or fail if exposed to splattering grease, oil, etc.
- Use dry gas which does not contain corrosive elements such as chlorine, sulfur or acids, and which is clean and does not contain dust or oil mist.
- Depending on the fluid, retaining the fluid for a long time could adversely affect performance. Do not seal the fluid in the pipe for long periods of time.

■ When using the valve with liquefied gases such as propane gas, always vaporize the gas. Failure may result if liquefied gas enters the product.

■ When using this product to control the burner air-fuel ratio, take design measures to prevent backfire and to avoid the effect of backfire on the product. Internal pressure increase in the piping or fire due to burner backfire may lead to failure.

■ Check that the pressure inside the fluid supply line is within the working differential pressure range before using. If the source pressure is low or the pressure at the secondary side is high, the differential pressure becomes insufficient and the fluid does not flow.

■ Due to the flow characteristics of the primary side regulator, the pressure is unstable when the flow rate flows, and FCM output may fluctuate.

**Design/selection**

F.R.L
F (Filtr)
R (Reg)
L (Lub)
PresSW
Shutoff
SlowStart
PhiResistFR
Oil-ProhR
MedPresFR
No Cu/ PTFE FRL
Outdrs FR
F.R.L (Related)
CompFRL
LgFRL
PrescR
VacF/R
Clean FR
ElecPneuR
AirBoost
SpdContr
Silncr
CheckV/ other
Jnt/tube
AirUnt
PresCompn
Mech/ ElecPresSw
ContactSW
AirSens
PresSW Cool
AirFloSens/ Contr
WaterPtSens
TotAirSys (Total Air)
TotAirSys (Gamma)
RefrDry
DesicDry
HiPolymDry
MainFiltr
Dischrg etc
Ending

**2. Working environment**

**⚠ WARNING**

- **Corrosive environments**  
Do not use this product in an atmosphere containing corrosive gases such as sulfur dioxide.
- **Ambient / fluid temperatures**  
Use at ambient / fluid temperatures within the specified range of 0 to 50°C.  
Even if the temperature is within the specified range, do not use in a location where the ambient / fluid temperatures could suddenly change and cause condensation.
- **Proof pressure/operating differential pressure range**  
Usage in applications exceeding the proof pressure or outside the operating differential pressure could result in failure. Use only within the specified range. If the source pressure is low or the pressure at the secondary side is high, the differential pressure decreases and the fluid does not flow.
- **Drip-proof environments**  
The degree of protection of this product is equivalent to IP40. Do not install this product where water, salt, dust, or swarf is present or in a pressurized or depressurized environment. The product cannot be used with large temperature variations or high temperature/humidity since condensation may occur inside the body.
- **The solenoid proportional valve inside this product does not have a fully closed function.**  
When a fully closed state is required, separately provide a cutoff valve outside the product.  
When the external cutoff valve is closed, keep the product valve in standby at a fully closed state (setting flow rate zero). If the product is left in the normal control state with the external cutoff valve closed, excessive flow is produced for a moment when the external cutoff valve is opened.  
When using with frequent ON/OFF operations, its service life as a proportional valve may be reduced depending on the working conditions.
- **Do not install this product in movable sections or where it will be subject to vibration. Vibration or impact may lead to malfunction.**

**⚠ CAUTION**

- **Check for leakage current to avoid malfunction caused by leakage current from other fluid control components.**  
When using a PLC, etc., leakage current could cause the product to malfunction.
- **When the current input is wired, the power ground and signal common are shared.**  
When operating this product in multiples with one PLC and D/A unit, depending on the D/A unit circuit, wiring trouble could prevent the correct signal from being input. Consult with the PLC manufacturer for use.

- **The current input can be used with an input signal of 1 to 5 V. However, because input impedance is small (250 Ω) when comparing to other voltage input, use an appropriate voltage generator.**
- **Be alert for pressure loss in the piping.**  
When piping to this product, keep the differential pressure between upstream and downstream sides within the operating differential pressure range (refer to pages 1335 and 1337). Using the product outside the operating differential pressure range could cause incorrect operation.  
In particular, an orifice or restriction in the secondary side (downstream side) of the product could cause incorrect operation. Please be careful. In addition, the pressure on the primary side or secondary side of the product may fluctuate repeatedly, or the product control may not be able to track pressure changes, leading to unstable flow rate control.
- **Working conditions for CE compliance**  
This product is CE-marked, indicating conformity with the EMC Directives. The standard for the immunity for industrial environments applied to this product is EN61000-6-2; the following requirements must be satisfied in order to conform to this standard:  
Conditions
  - The assessment of this product is performed by using a cable pairing a power supply line and a signal line, assessing this cable as a signal line.
  - This product is not equipped with surge immunity. Implement surge protection measures on the system side.

**3. Flow rate unit**

**⚠ CAUTION**

- **This product's flow rate is measured at a mass flow rate unaffected by temperature or pressure. The unit is l/min., but this is the display when the mass flow rate is converted to volumetric flow rate at 20°C 1 barometric pressure (101 kPa) relative humidity 65%.**

## Mounting, installation and adjustment

### 1. Wiring

#### **⚠ DANGER**

- Use power supply voltage and output within the specified voltage. If voltage exceeding the specified voltage is applied, the product could malfunction or be damaged, or electrical shock or fire could occur. Do not use any load that exceeds the rated output. Otherwise, output damage or fire may result.

#### **⚠ WARNING**

- Check the connector pin and cable conductor wire color when wiring. Incorrect connections could cause product damage, problems, or malfunctions. Check the wire color against instructions and precautions before wiring.

- Ensure that wires are properly insulated. Check that wires do not come into contact with other circuits, that no ground faults occur, and that the insulator between terminals is not defective. Otherwise, overcurrent may flow into the product, causing damage.

- Use a stabilized DC power supply within the specified rating that has been insulated from the AC power supply. A non-insulated power supply could result in electrical shock. If power is not stabilized, the peak value in hot summer could exceed the rating and damage the product or reduce precision.

- Stop the control device and equipment and turn power OFF before wiring. Starting operation suddenly could cause unpredictable and dangerous operation. First, conduct an energized test with controls and machinery stopped, and set target data. Be sure to discharge any accumulated electrostatic charge among personnel, tools, or equipment before and during work. Connect and wire bending resistant material, such as robot wire material for movable sections.

- Do not use at levels exceeding the power supply voltage range. The product could rupture or burn if voltage exceeding the specification range or AC power supply (100 VAC) is applied.

- Install this product and wiring as far away as possible from sources of noise such as power distribution wires. Provide separate countermeasures for surge applied to the power cable.

- Do not short-circuit the load. Failure to observe this could result in rupture or burning.

- The power supply for the stainless steel body is a DC stabilized power supply completely isolated from the AC primary side. Connect either the + side or - side of the power to the F.G. Between the internal power circuit and stainless steel body, a varistor (limit voltage approx. 40 V) is connected to prevent dielectric breakdown of the product. Do not conduct a withstand voltage test or insulation resistance test between the internal power circuit and stainless steel body. Disconnect wiring first if this testing is required. An excessive potential difference between power and stainless steel body will burn internal parts. After installing, connecting and wiring the stainless steel body, electrical welding of the device/frame, or short-circuit accidents, etc., could cause welding current, excessive high voltage caused by welding, or surge voltage, etc., to run through wiring, ground wire, or fluid path connected between such devices, damaging wires or devices. Conduct any work such as electrical welding after removing this device and disconnecting all electric wires connected to the F.G.

#### **⚠ CAUTION**

- The optional shield cable connector is a shielded wire. Insulate wires not being used so that they do not contact other wires, including shielded wires. Unintended connection to the ground, etc., could cause malfunction or damage the product.

- Check the direction of the D sub-connector, and then insert and fit it securely through to the back.

- Lock the D sub-connector so that it will not be dislocated. Before loosening the lock, fix the fixing block with a tool, etc.

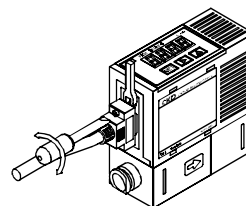

- Extension of cable  
When extending the cable beyond 3 m, the analog output and analog input error may increase or the control may become unstable due to wiring resistance. Use of a cable within 3 m is recommended.



### Mounting, installation and adjustment

F.R.L
F (Filtr)
R (Reg)
L (Lub)
PresSW
Shutoff
SlowStart
PhiResistFR
Oil-ProhR
MedPresFR
No Cu/ PTFE FRL
Outdrs FR
F.R.L (Related)
CompFRL
LgFRL
PrecsR
VacF/R
Clean FR
ElecPneuR
AirBoost
SpdContr
Silncr
CheckV/ other
Jnt/tube
AirUnt
PresCompn
Mech/ ElecPresSW
ContactSW
AirSens
PresSW Cool
AirFloSens/ Contr
WaterPtSens
TotAirSys (Total Air)
TotAirSys (Gamma)
RefrDry
DesicDry
HiPolymDry
MainFiltr
Dischrg etc
Ending

## 2. Piping

### CAUTION

- Align the fluid flow direction to the direction indicated on the body when connecting the pipes.
- Fitting tightening with 4S, 4RM port size (hydrogen/helium model).

#### (1) Fitting tightening method

4RM (1/4" JXR male fitting)...when the gasket material is nickel/SUS316

Tighten the nut with fingers until the gasket contacts the bead surface, and then tighten another 1/8 turn with a tool.

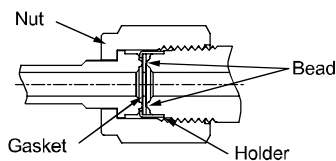

4S (double barbed fitting)...Confirm that the front ferrule, back ferrule and nuts are properly attached, and then insert the tube until it contacts the back of the body. Tighten the nuts as far as possible with fingers, and then tighten 1 1/4 turn with a tool.

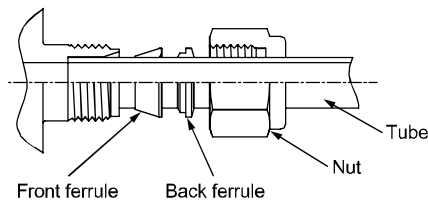

- Before piping, clean out the pipes using an air blower to remove all foreign matter and cutting chips from the pipes. The rectifier or platinum sensor could be damaged if foreign matter, cutting chips, etc., should enter.
- When installing this product on piping, refer to the torque below so that excessive screw-in torque or load torque is not applied to the connection port.

Port thread	Tightening torque N·m
Rc1/4	6 to 8
9/16-18UNF	6 to 8

- Hook a wrench to the stainless steel body when tightening pipes so that force is not applied to the resin section.

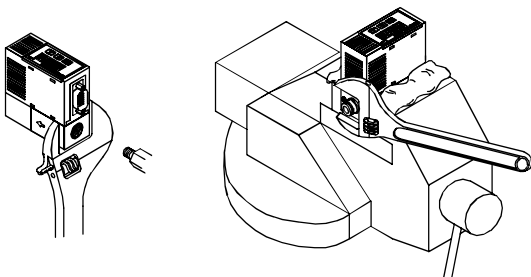

- Make sure that no sealing tape or adhesive enters the pipes when connecting the piping.

- When connecting pipes, wrap sealing tape in the opposite direction from the threading, from the inside position to within 2 mm from the pipe end.
  - If sealing tape protrudes from the pipe threads, it could be cut when screwing the bolts in. This could cause the tape to enter the solenoid valve, causing failures.

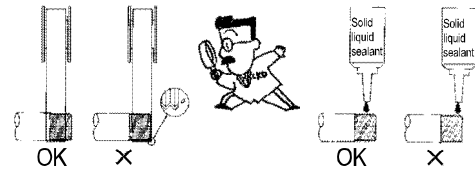

When using a liquid sealant, make sure to keep it away from resin parts. Otherwise resin parts could be damaged, which is dangerous.

- If the piping is removed once, sealant may remain on the thread part. When repiping, remove the remaining sealant.
- Be sure to connect a fitting even when using the stainless steel body with the OUT side opened. The port filter could come OFF.
- When the resin body is used, do not bend the tube near the push-in fitting. If stress is applied to the tube near the push-in fitting, insert an insert ring into the tube, and connect the tube to the push-in fitting.
- When the resin body is used, securely insert the tube, and make sure that it cannot be pulled out. Cut the tube at a right angle with a dedicated cutter before use.
- After piping, check that there are no gas leaks.
- When using this product for oxygen gas, take special care with the points below.
  - The piping work should be performed by an expert in the handling of oxygen gas.
  - Use piping with oil-free processing.
  - Make sure to remove dirt, burrs, etc., in the piping before installing the product.
  - Install a filter on the primary side of the product.
- Do not install the regulator/solenoid valve, etc., immediately before this product. Generated drift may cause errors. Provide a straight piping section if required.
- Although the mounting is "unrestricted in vertical/horizontal direction", the flow rate may vary depending on difference in the mounting orientation or piping conditions.
- Do not install multiple bodies in close contact. The mutual generation of heat could cause the product body's temperature to rise, hastening changes in characteristics or in the resin material. When using the products in a row, set intervals of distance of 10 mm or more.

## Use/maintenance

F.R.L
F (Filtr)
R (Reg)
L (Lub)
PresSW
Shutoff
SlowStart
FlmResistFR
Oil-ProhR
MedPresFR
No Cu/ PTFE FRL
Outdrs FR
F.R.L (Related)
CompFRL
LgFRL
PrecsR
VacFR
Clean FR
ElecPneuR
AirBoost
SpdContr
SiIncr
CheckV/ other
Jnt/tube
AirUnt
PrecsCompn
Mech/ ElecPresSw
ContactSW
AirSens
PresSW Cool
AirFloSens/ Contr
WaterRtSens
TotAirSys (Total Air)
TotAirSys (Gamma)
RefrDry
DesicDry
HiPolymDry
MainFiltr
Dischrg etc
Ending

### ⚠ WARNING

- Output accuracy is affected by temperature characteristics and heat generated when energized. Provide sufficient stand-by time (10 minutes or more after energizing) before use.

### ⚠ CAUTION

- This product uses a micro-sensor chip, and must be installed where it will not be subject to dropping, impact or vibration. Treat the product as a precision component during installation and transportation.

- If a problem occurs during operation, immediately turn the power OFF, stop use and contact your dealer.

- Immediately after power is turned ON, the product does not start flow rate control operation for approx. 2 seconds to complete self-diagnosis. Provide a control circuit/program that ignores signals for at least two seconds after power is turned ON.

- Keep this product's flow rate within the rated flow range.

- Use the product within the operating differential pressure range.

- When changing the setting value, turn OFF the equipment first in order to prevent unexpected operation of the control system.

- Do not disassemble or modify, as this may cause malfunction.

- The case is made of resin. Do not use solvent, alcohol or detergent in cleaning, or resin could absorb it. There is a risk of affecting the resin. Wipe off dirt with a rag soaked in a diluted neutral detergent solution and wrung out well.

- Pay attention to surge current leading.

When the power supply for this product is shared with an inductive load that generates surges, such as a solenoid valve or relay, if the circuit is cut off while the inductive load is functioning, surge current could enter the switch output circuit and cause damage depending on where the surge absorbing element is installed.

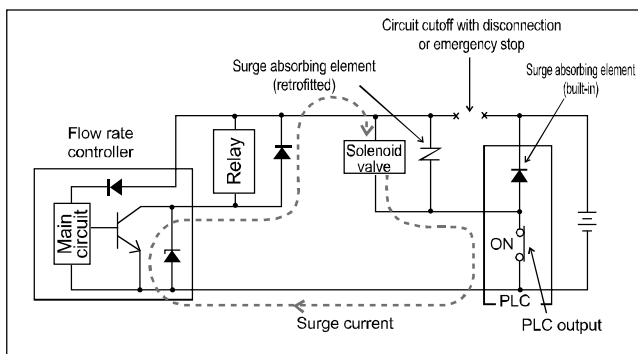

Take the measures as written on the right to prevent damage from sneak surge current.

- Separate the power supply for output including the inductive load, such as the solenoid valve and relay, and input, such as the flow rate controller.
- If a separate power supply cannot be used, directly install a surge absorption element for all inductive loads. Consider that the surge absorption element connected to the PLC, etc., protects only the individual device.
- Connect a surge absorption element to places on the power wiring shown in the figure below, as a measure against disconnections in unspecified areas.

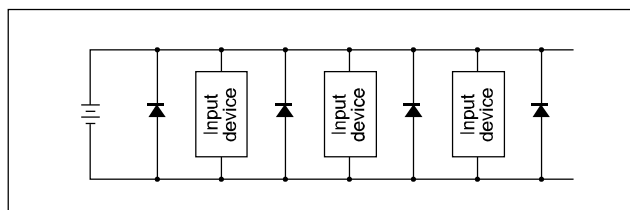

When the devices are connected to a connector, the output circuit could be damaged by the above phenomenon if the connector is disconnected while the power is ON. Turn power OFF before connecting or disconnecting the connector.

- The accuracy may vary from the initial status depending on the working environment or working conditions. It is recommended to check the operation of the product periodically.
- The sensor chip will degrade when used for a long time and cause the detected flow rate to fluctuate. Periodically inspect the sensor chip.