

Compact flow rate sensor

FSM2 (RAPIFLOW®)

■ Sensor controller/flow rate sensor



CONTENTS

Product introduction	1234
Applications	1236
● Display integrated/display separated	1238
● FSM Series dedicated inline filter	1320
FSM2 Technical data	1266
▲ Safety precautions	1282

F.R.L
F (Filtr)
R (Reg)
L (Lub)
PresSW
Shutoff
SlowStart
FmResistFR
Oil-ProhR
MedPresFR
No Cu/ PTFE FRL
Outdrs FR
F.R.L (Related)
CompFRL
LgFRL
PrecsR
VacF/R
Clean FR
ElecPneuR
AirBoost
SpdContr
Silncr
CheckV/ other
Jnt/tube
AirUnt
PresCompn
Mech/ ElecPresSw
ContactSW
AirSens
PresSW Cool
AirFloSens/ Contr
WaterPtSens
TotAirSys (Total Air)
TotAirSys (Gamma)
RefrDry
DesicDry
HiPolymDry
MainFiltr
Dischrg etc
Ending

F.R.L
F (Filtr)
R (Reg)
L (Lub)
PresSW
Shutoff
SlowStart
FmResisFR
Oil-ProhR
MedPresFR
No Cu/ PTFE FRL
Outdrs FR
F.R.L (Related)
CompFRL
LgFRL
PrecsR
VacF/R
Clean FR
ElecPneuR
AirBoost
SpdContr
Silncr
CheckV/ other
Jnt/tube
AirUnt
PrecsCompn
Mech/ ElecPresSw
ContactSW
AirSens
PresSW Cool
AirFloSens/ Contr
WaterRtSens
TotAirSys (Total Air)
TotAirSys (Gamma)
RefrDry
DesicDry
HiPolymDry
MainFiltr
Dischrg etc
Ending

Small size flow rate sensor/RAPIFLOW **FSM2 Series**

Line-up to match your every need

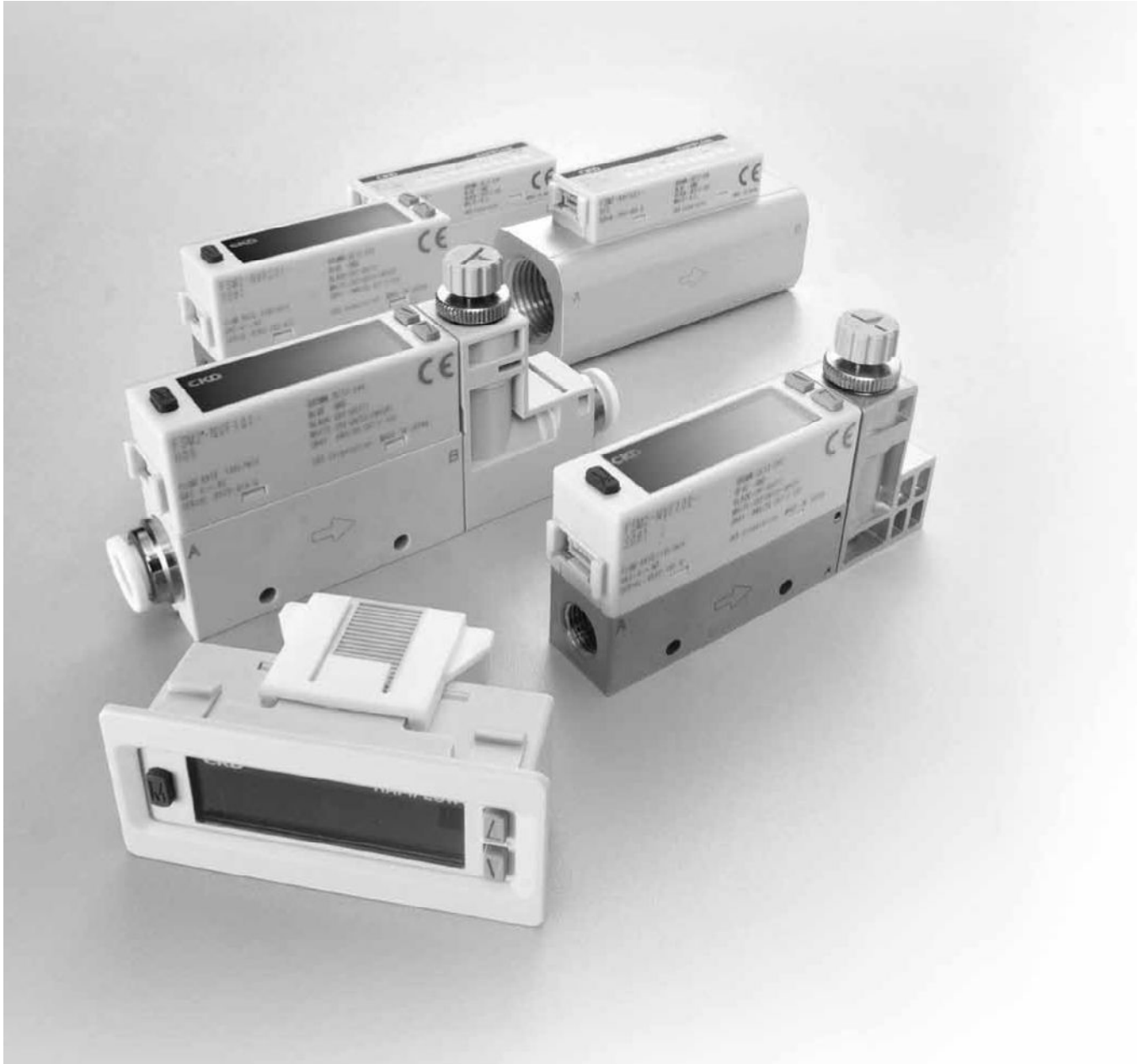

Needle valve integrated

The needle valve, which can adjust the flow rate, has been integrated with the sensor to simplify piping. Space-saving installation is also possible.

Stainless steel bodies also available



Stainless steel body



Resin body

Separated display

When connected to a sensor, the separated display automatically recognizes the flow rate range, and so settings with the display are not required. Complete wiring easily with the connector connection method.



* Only in the default state or when settings are reset. Refer to "Explanation of functions" on page 1276 for details.

Functions which pursue the operability of the small flow rate sensor provide the best selections for various contexts and applications.

Clean-room specifications (P70,P80)

The P70 (anti-dust generation) and P80 (oil-prohibited) specifications are available as standard. These models are perfect for semiconductor and liquid crystal manufacturing applications.

Panel mounting possible

A panel mounting bracket is available. The separated display, sensor body (up to display integrated 200 l/min) and needle valve integrated can be mounted onto a panel.

Close mounting with one panel opening is possible, allowing man-hours and space to be reduced when using multiple units.

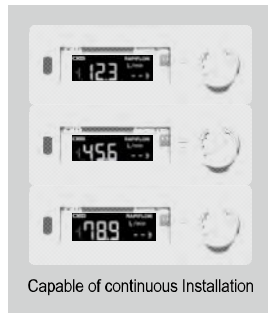

Compact even with large flow rate

With the 500 and 1000 l/min types, the body size has been reduced by 30% compared to conventional models, attaining the highest downsizing in the industry. Downsize and lighten your equipment with this model.

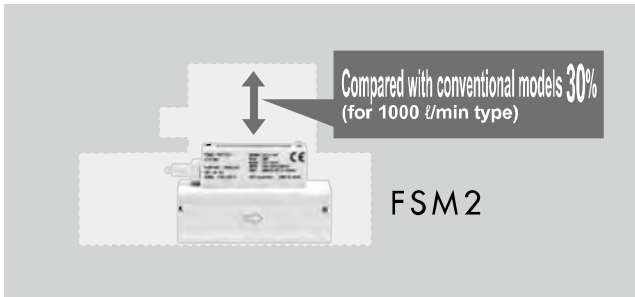

Bi-directional fluid measurement

The flow direction can be randomly set for measurement with the display integrated bi-directional. This increases the freedom of piping installation, and can be used for detecting reverse flows.

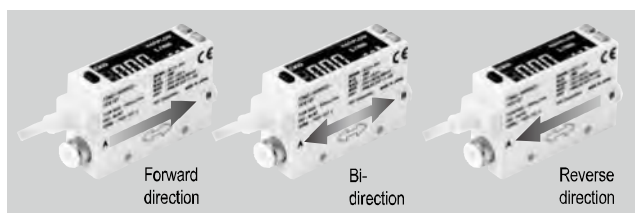

Twin display/2-color display function

A main screen and sub screen can be provided with the display integrated, improving operability. The errors can be seen at a glance with the 2-color display.

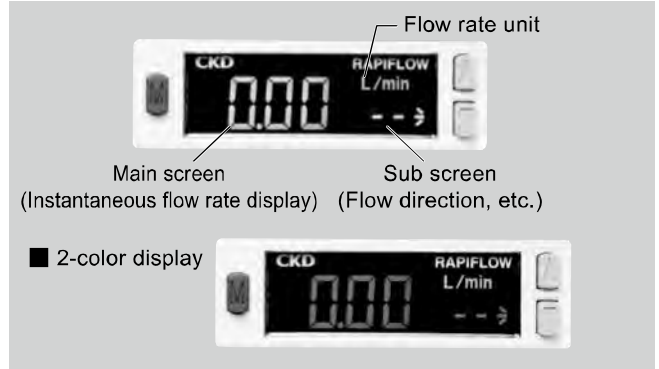

Bar display function

On the separated display, the reference flow rate can be seen at a glance with the flow bar display.



Improvement of accuracy Within ±3% F.S.

An accuracy of ±3% F.S. allows for a more accurate flow rate measurement.

High-speed response 50 msec or less

The platinum sensor chip manufactured with silicon micromachining realizes a high speed response. Contributes to reducing tact time.

Unrestricted in the mounting orientations

The sensor can be mounted in any direction, top, bottom, left or right.

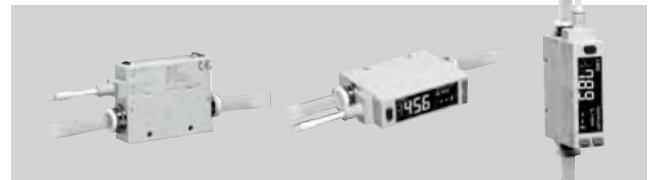

Straight piping section not required

The newly proposed rectifying mechanism eliminates the need for straight piping at either the upstream or downstream side.





F.R.L
F (Filtr)
R (Reg)
L (Lub)
PresSW
Shutoff
SlowStart
PhiResistFR
Oil-ProhR
MedPresFR
No Cu/ PTFE FRL
Outdrs FR
F.R.L (Related)
CompFRL
LgFRL
PrecsR
VacF/R
Clean FR
ElecPneuR
AirBoost
SpdContr
Silncr
CheckV/ other
Jnt/tube
AirUnt
PresCompn
Mech/ ElecPresSw
ContactSW
AirSens
PresSW Cool
AirFloSens/ Contr
WaterPtSens
TotAirSys (Total Air)
TotAirSys (Gamma)
RefrDry
DesicDry
HiPolymDry
MainFiltr
Dischrg etc
Ending

Diverse lineup to match your needs

- F.R.L
- F (Filtr)
- R (Reg)
- L (Lub)
- PresSW
- Shutoff
- SlowStart
- FmResistFR
- Oil-ProhR
- MedPresFR
- No Cu/ PTFE FRL
- Outdrs FR
- F.R.L (Related)
- CompFRL
- LgFRL
- PrecsR
- VacFR
- Clean FR
- ElecPneUR
- AirBoost
- SpdContr
- Silncr
- CheckV/ other
- Jnt/tube
- AirUnt
- PrecsCompn
- Mech/ ElecPresSw
- ContactSW
- AirSens
- PresSW Cool
- AirFloSens/ Contr
- WaterRtSens
- TotAirSys (Total Air)
- TotAirSys (Gamma)
- RefrDry
- DesicDry
- HiPolymDry
- MainFiltr
- Dischrg etc
- Ending

Flow rate range/port size/body material



Body material	Port size	Full scale flow rate											
		500 ml/min	1 l/min	2 l/min	5 l/min	10 l/min	20 l/min	50 l/min	100 l/min	200 l/min	500 l/min	1,000 l/min	
Resin 	φ4 push-in	●	●	●	●	●	●						
	φ6 push-in	●	●	●	●	●	●	●					
	φ8 push-in							●	●	●			
	φ10 push-in								●	●			
Stainless steel 	Rc1/8	●	●	●	●	●	●	●	*1				
	Rc1/4								●	●	*2		
	M5	●	●	●	●	●	●	*1					
Aluminum 	Rc1/2										●	●	

*1: Excluding carbon dioxide models. *2: Excluding argon models and carbon dioxide models.

Applicable fluids

Applicable fluids	Body material	Full scale flow rate											
		500 ml/min	1 l/min	2 l/min	5 l/min	10 l/min	20 l/min	50 l/min	100 l/min	200 l/min	500 l/min	1,000 l/min	
Air, nitrogen	Resin	●	●	●	●	●	●	●	●	●			
	Stainless steel	●	●	●	●	●	●	●	●	●			
	Aluminum										●	●	
Argon	Stainless steel	●	●	●	●	●	●	●	●	●			
Carbon dioxide	Stainless steel	●	●	●	●	●	●	●	●				

Output

Type	Output
Display integrated 	Analog output 1 point (1 to 5 V or 4 to 20 mA) Switch output 2 points (NPN or PNP)
Display separated 	Analog output 1 point (1 to 5 V or 4 to 20 mA) Capable of connecting separated display



Needle valve integrated (option)

Supporting up to full scale 200 l/min (only for display integrated)

- Resin body
- Stainless steel body



Flow direction

Bi-directional	Uni-direction
	
Flow direction can be selected with button operations (display integrated)	

Clean-room specifications (Option)

- P70 specifications: Countermeasures for dust generation
- P80 specifications: Oil-prohibited

Applications

Air consumption flow rate control

The air consumed by the discrete equipment can be seen by monitoring the integrated pulse output or analog output.

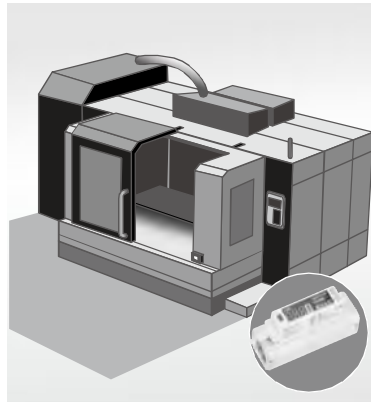
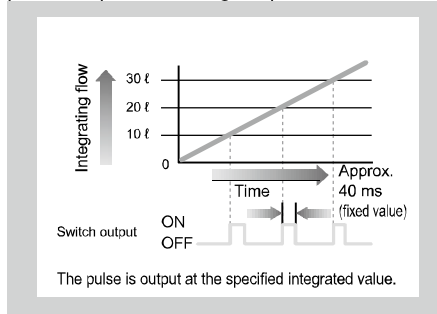

Painting air flow rate control

P80 (oil-prohibited specifications) are perfect for controlling the flow rate of painting air. FSM2 is free of siloxane (organic silicone), so the paint quality is stable.

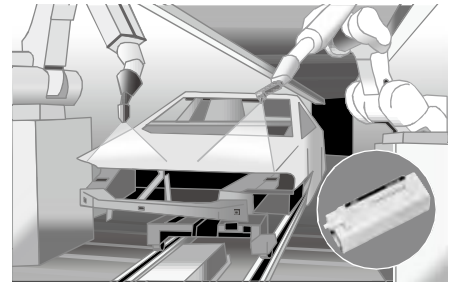

Semiconductor manufacturing system purge gas flow rate control

Control of the purge gas is indispensable for maintaining the performance of a semiconductor manufacturing system. The stainless steel body is suitable for applications which are susceptible to discharged gases. Errors can be detected by using the switch output.

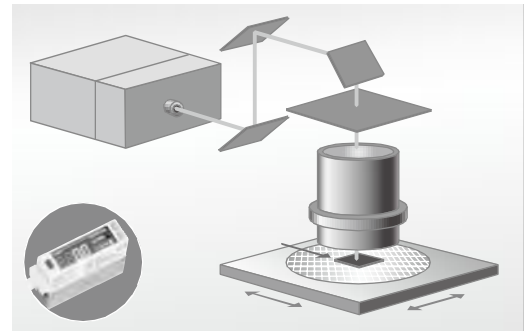
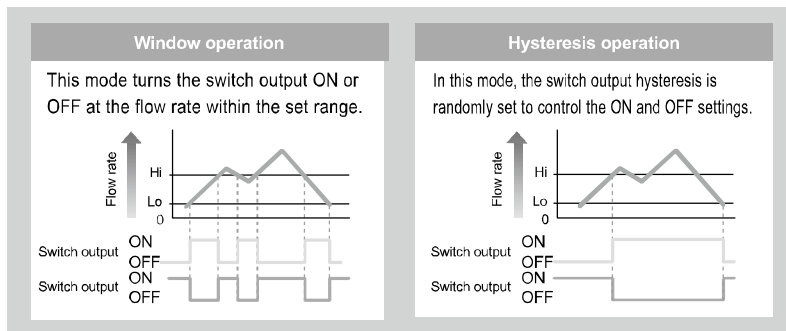

Ionizer flow rate control

The flow rate can be easily adjusted with the needle valve integrated. The P80 (oil-prohibited specifications) are suitable for clean applications. Errors can be detected by using the switch output.

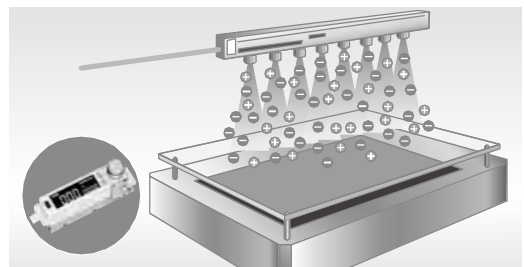

Suction confirmation

Since the flow rate is detected, there is no need to make adjustments according to pressure fluctuations and incorrect detections are eliminated. Capable of managing detection of a clogged nozzle or filter and of a suction failure such as oblique suction.

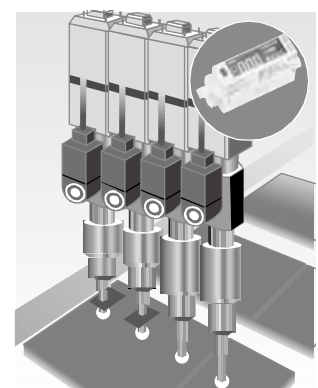
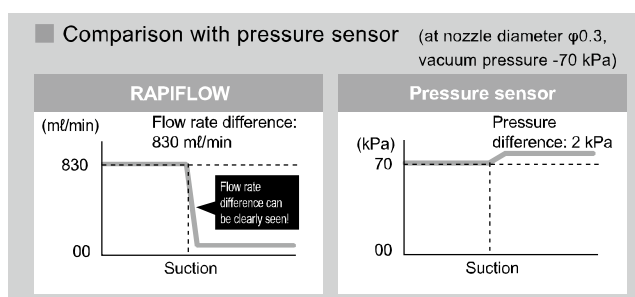

F.R.L
F (Filtr)
R (Reg)
L (Lub)
PresSW
Shutoff
SlowStart
FmResistFR
Oil-ProhR
MedPresFR
No Cu/ PTFE FRL
Outdrs FR
F.R.L (Related)
CompFRL
LgFRL
PrecsR
VacF/R
Clean FR
ElecPneuR
AirBoost
SpdContr
Silncr
CheckV/ other
Jnt/tube
AirUnt
PresCompn
Mech/ ElecPresSw
ContactSW
AirSens
PresSW Cool
AirFloSens/ Contr
WaterPtSens
TotAirSys (Total Air)
TotAirSys (Gamma)
RefrDry
DesicDry
HiPolymDry
MainFiltr
Dischrg etc
Ending



Small flow rate sensor RAPIFLOW
display integrated/display separated

FSM2 Series

- Resin body (flow rate range: 500 ml/min. to 200 l/min.)
- Aluminum body (flow rate range: 500 l/min., 1000 l/min.)
- Stainless steel body (flow rate range: 500 ml/min. to 200 l/min.)



Display integrated (resin/aluminum body) specifications



Descriptions		Display integrated (resin/aluminum body) specifications FSM2-[*1][*2][*3][*4][*5][*6][*7]													
		Full scale flow rate	005	010	020	050	100	200	500	101	201	501	102		
Flow rate range *1	*4	005	500 ml/min	●											
		010	1 l/min		●										
		020	2 l/min			●									
		050	5 l/min				●								
		100	10 l/min					●							
		200	20 l/min						●						
		500	50 l/min							●					
		101	100 l/min								●				
		201	200 l/min									●			
		501	500 l/min										●		
		1000 l/min										●			
Port size/ body material	*5	H04	φ4 Push-in / resin	●	●	●	●	●	●						
		H06	φ6 Push-in / resin	●	●	●	●	●	●						
		H08	φ8 Push-in / resin							●	●	●			
		H10	φ10 Push-in / resin								●	●			
		A15	Rc1/2 / aluminum										●	●	
Needle valve integrated	*1	*6	N	●	●	●	●	●	●	●	●	●	●		
Flow rate display *2, *3	Display	*3	F	4 digit + 4 digit 2 color LCD											
				0 to 500 ml/min	0 to 1000 ml/min	0 to 2.00 l/min	0 to 5.00 l/min	0 to 10.00 l/min	0 to 20.0 l/min	0 to 50.0 l/min	0 to 100.0 l/min	0 to 200 l/min	0 to 500 l/min	0 to 1000 l/min	
			R	-500 to 500 ml/min	-1000 to 1000 ml/min	-2.00 to 2.00 l/min	-5.00 to 5.00 l/min	-10.00 to 10.00 l/min	-20.0 to 20.0 l/min	-50.0 to 50.0 l/min	-100.0 to 100.0 l/min	-200 to 200 l/min	-500 to 500 l/min	-1000 to 1000 l/min	
			Display resolution	1 ml/min			0.01 l/min			0.1 l/min			1 l/min		
Integrating functions *4	Display range	9999999 ml			99999.99 l			999999.9 l			9999999 l				
		Display resolution	1 ml			0.01 l			0.1 l			1 l			
			Integrated pulse output rate	5 ml	10 ml	0.02 l	0.05 l	0.1 l	0.2 l	0.5 l	1 l	2 l	5 l	10 l	
Working conditions	Applicable fluid	*5	Clean air (JIS B 8392-1:2012 (ISO 8573-1:2010) [1:1:1 to 5:6:2]), compressed air (JIS B 8392-1:2012 (ISO 8573-1:2010) [1:1:1 to 1:6:2]), nitrogen gas												
	Max. working pressure	0.7 MPa (≈100 psi, 7 bar)													
	Min. working pressure	-0.09 MPa (≈-13 psi, -0.9 bar)													
	Proof pressure	1 MPa (≈150 psi, 10 bar)													
	Operating ambient temperature/humidity	0 (32°F) to 50°C (122°F), 90% RH or less													
Accuracy	Fluid temperature	0 (32°F) to 50°C (122°F) (no condensation)													
	Working range	Uni-direction: 3 to 100% F.S., bi-direction: -100 to -3% F.S., 3 to 100% F.S.													
	Linearity (display/analog output)	Within ±3% F.S. (Secondary side released to atmosphere)													
	Pressure characteristics	Within ±5% F.S. (-0.09 to 0.7 MPa, where secondary side is released to atmosphere)													
	Temperature characteristics	Within ±0.2% F.S./°C (15 to 35°C, 25°C reference)													
Repeatability	Within ±1% F.S.														
Response time	*7 50 ms or less														
Output	Switch output	*1	N	Output 2 points (NPN open collector output, 50 mA or less, voltage drop 2.4 V or less)											
		P	Output 2 points (PNP open collector output, 50 mA or less, voltage drop 2.4 V or less)												
	Analog output	*2	V	1 to 5 V voltage output 1 point (connecting load impedance 50 kΩ and over) *8											
		A	4 to 20 mA current output 1 point (connecting load impedance 0 to 300 Ω)												
Power supply voltage	*9	*2	V	12 to 24 VDC(10.8 to 26.4 V)											
		A	24 VDC (21.6 to 26.4 V)												
Current consumption	*10 50 mA or less														
Cable	φ3.7, AWG26 or equivalent x 5-conductor (connector connection), insulator outer diameter φ1.0														
Functions	Flow rate display, flow rate display peak hold, switch output, analog output, etc.														
Mounting	Mounting orientation	Unrestricted in vertical/horizontal direction													
	Straight piping section	Not required													
Degree of protection	IEC standards IP40 or equivalent														
Protection circuit	*11 Power reverse connection protection, switch output reverse connection protection, switch output load short-circuit protection														
EMC Directive	EN55011, EN61000-6-2, EN61000-4-2/3/4/6/8														
Weight (main body only)	*5	H04	Approx. 50 g (approx. 80 g with needle valve)												
		H06	Approx. 50 g (approx. 80 g with needle valve)												
		H08	Approx. 70 g (approx. 110 g with needle valve)												
		H10	Approx. 75 g (approx. 115 g with needle valve)												
		A15	Approx. 155 g												
Clean-room specifications	*7	P70	Anti-dust generation *12												
		P80	Oil free *13												



Display integrated (stainless steel body) specifications

1 MPa = 10 bar

Descriptions		Display integrated (stainless steel body) FSM2-[*1][*2][*3][*4][*5][*6][*7][*8]										
		Full scale flow rate	005	010	020	050	100	200	500	101	201	
Flow rate range *1	*4	005	500 ml/min	●								
		010	1 l/min		●							
		020	2 l/min			●						
		050	5 l/min				●					
		100	10 l/min					●				
		200	20 l/min						●			
		500	50 l/min							●		
		101	100 l/min								●	
Port size/ body material	*5	S06	Rc1/8 Stainless steel	●	●	●	●	●	●	(Not for CO ₂)		
		S08	Rc1/4 Stainless steel							●	●	
		SM5	M5 Stainless steel (Custom order product)	●	●	●	●	●	●	(Not for CO ₂)		
Needle valve integrated	*1	*7	N	●	●	●	●	●	●	●		
Flow rate display *2, *3	Display		4 digit + 4 digit 2 color LCD									
	Display range	*3	F	0 to 500 ml/min	0 to 1000 ml/min	0 to 2.00 l/min	0 to 5.00 l/min	0 to 10.00 l/min	0 to 20.0 l/min	0 to 50.0 l/min	0 to 100.0 l/min	0 to 200 l/min
			R	-500 to 500 ml/min	-1000 to 1000 ml/min	-2.00 to 2.00 l/min	-5.00 to 5.00 l/min	-10.00 to 10.00 l/min	-20.0 to 20.0 l/min	-50.0 to 50.0 l/min	-100.0 to 100.0 l/min	-200 to 200 l/min
	Display resolution		1 ml/min			0.01 l/min			0.1 l/min			1 l/min
Integrating functions *4	Display range		9999999 ml			99999.99 l			999999.9 l			9999999 l
	Display resolution		1 ml			0.01 l			0.1 l			1 l
	Integrated pulse output rate		5 ml	10 ml	0.02 l	0.05 l	0.1 l	0.2 l	0.5 l	1 l	2 l	
	Applicable fluid		*6	Blank	Clean air (JIS B 8392-1:2012 (ISO 8573-1:2010) [1:1 to 5:6:2]), compressed air (JIS B 8392-1:2012 (ISO 8573-1:2010) [1:1 to 1:6:2]), nitrogen gas							
Max. working pressure		AR		Argon								
Min. working pressure		C2		Carbon dioxide (CO ₂)								
Proof pressure		1.5 MPa (≈220 psi, 15 bar)										
Operating ambient temperature/humidity		0 (32°F) to 50°C (122°F), 90% RH or less										
Fluid temperature		0 (32°F) to 50°C (122°F) (no condensation)										
Working range		Uni-direction: 3 to 100% F.S., bi-direction: -100 to -3% F.S., 3 to 100% F.S.										
Linearity (display/analog output)		Within ±3% F.S. (Secondary side released to atmosphere)										
Pressure characteristics		Within ±5% F.S. (-0.09 (≈-13 psi) to 0.7 MPa (≈100 psi), where secondary side is released to atmosphere)										
Temperature characteristics		Within ±0.2% F.S./°C (15 (59°F) to 35°C (95°F), 25°C (77°F) reference)										
Repeatability		Within ±1% F.S.										
Response time		*7 50 ms or less										
Output	Switch output	*1	N	Output 2 points (NPN open collector output, 50 mA or less, voltage drop 2.4 V or less)								
			P	Output 2 points (PNP open collector output, 50 mA or less, voltage drop 2.4 V or less)								
	Analog output	*2	V	1 to 5 V voltage output 1 point (connecting load impedance 50 kΩ and over) *8								
Power supply voltage	*9	*2	V	12 to 24 VDC (10.8 to 26.4 V)								
			A	24 VDC (21.6 to 26.4 V)								
Current consumption		*10 50 mA or less										
Lead wire		φ3.7, AWG26 or equivalent x 5-conductor (connector connection), insulator outer diameter φ1.0										
Functions		Flow rate display, flow rate display peak hold, switch output, analog output, etc.										
Mounting	Mounting orientation		Unrestricted in vertical/horizontal direction									
	Straight piping section		Not required									
Degree of protection		IEC standards IP40 or equivalent										
Protection circuit		*11 Power reverse connection protection, switch output reverse connection protection, switch output load short-circuit protection										
EMC Directive		EN55011, EN61000-6-2, EN61000-4-2/3/4/6/8										
Weight (main body only)	*5	S06	Approx. 95 g (approx. 160 g with needle valve)									
		S08	Approx. 115 g (approx. 200 g with needle valve)									
		SM5	Approx. 140 g									
Clean-room specifications	*8	P70	Anti-dust generation *12									
		P80	Oil free *13									

- *1: This valve cannot be used as a stop valve that requires no leakage. Slight leakage is allowed for in the specifications.
 - *2: The value converted to volumetric flow rate at standard condition (20°C 1 barometric pressure (101 kPa) relative humidity 65%)
 - *3: The flow rate display is rounded off at approx. ±1% F.S. or less (forced zero).
 - *4: The integrating flow is a calculated (reference) value. It is reset when the power is turned OFF.
 - *5: Use dry gas which does not contain corrosive elements such as chlorine, sulfur or acids, and which is clean and does not contain dust or oil mist. When using compressed air, use clean air compliant with JIS B8392-1:2012 Grade (1:1 to 1:6:2). Compressed air from the compressor contains drainage (water, oil oxides, foreign matter, etc.). To maintain the function of this product, install a filter, air dryer (min. pressure dew point 10°C or less), and oil mist filter (max. oil content 0.1 mg/m³) on the primary side (upstream side) of this product. [Recommended circuit]
- Pneumatic source → Air dryer → Filter → Regulator → Oil mist filter (micro alescerc) → FSM2 Series

[Recommended device]
Air filter: F series
Oil mist filter: M series
- *6: Calibration of this product is performed within specified range. Accuracy conditions: Temperature 25±3 °C, power supply voltage 24±0.01 VDC. F.S. stands for full scale flow rate.
 - *7: Response time can be set in seven steps from 50 ms. or less to approx. 1.5 s.
 - *8: The output impedance of the analog output section is approx. 1 kΩ. If the impedance of the connecting load is small, output and error increase. Check error with the impedance of the connecting load before using.
 - *9: The power supply voltage specifications differ for the voltage output and current output.
 - *10: Current for when 24 VDC is connected, and no load is applied. The current consumption will vary depending on how the load is connected.
 - *11: This product's protection circuit is effective only for specific misconnections and load short-circuits. It does not provide protection for all misconnections.
 - *12: [P70] Anti-dust generation (product surface is degreased and cleaned before packing. Heat sealed into antistatic bag in clean bench (Class 1000 and over).)
 - *13: [P80] Oil free (In addition to P70 specifications, gas-contact sections are degreased and cleaned. Refer to the "Internal structure and parts list" for details on the gas-contact materials.)

F.R.L
F (Filtr)
R (Reg)
L (Lub)
PresSW
Shutoff
SlowStart
FlnResistFR
Oil-ProhR
MedPresFR
No Cu/ PTFE FRL
Outdrs FR
F.R.L (Related)
CompFRL
LgFRL
PrecsR
VacF/R
Clean FR
ElecPneUR
AirBoost
SpdContr
Silncr
CheckV/ other
Jnt/tube
AirUnt
PresCompn
Mech/ ElecPresSw
ContactSW
AirSens
PresSW Cool
AirFloSens/ Contr
WaterRtSens
TotAirSys (Total Air)
TotAirSys (Gamma)
RefrDry
DesicDry
HiPolymDry
MainFiltr
Dischrg etc
Ending

Display separated (resin/aluminum body) specifications



1 MPa = 10 bar

Descriptions		Display separated (resin/aluminum body) FSM2-A[*1][*2][*3]-[*4]-[*5]											
		Full scale flow rate	005	010	020	050	100	200	500	101	201	501	102
Flow rate range *1	*3	005	500 ml/min	●									
		010	1 l/min		●								
		020	2 l/min			●							
		050	5 l/min				●						
		100	10 l/min					●					
		200	20 l/min						●				
		500	50 l/min							●			
		101	100 l/min								●		
		201	200 l/min									●	
		501	500 l/min										●
102	1000 l/min											●	
Port size/ body material	*4	H04	φ4 Push-in / resin	●	●	●	●	●	●				
		H06	φ6 Push-in / resin	●	●	●	●	●	●				
		H08	φ8 Push-in / resin							●	●	●	
		H10	φ10 Push-in / resin								●	●	
		A15	Rc1/2 / aluminum										●
Flow direction		*2	F	Uni-direction									
			R	Bi-direction									
Working conditions	Applicable fluid		*2	Clean air (JIS B 8392-1:2012 (ISO 8573-1:2010) [1:1:1 to 5:6:2]), compressed air (JIS B 8392-1:2012 (ISO 8573-1:2010) [1:1:1 to 1:6:2]), nitrogen gas									
	Max. working pressure			0.7 MPa (≈100 psi, 7 bar)									
	Min. working pressure			-0.09 MPa (≈-13 psi, -0.9 bar)									
	Proof pressure			1 MPa (≈150 psi, 10 bar)									
	Operating ambient temperature/humidity			0 (32°F) to 50°C (122°F), 90% RH or less									
	Fluid temperature			0 (32°F) to 50°C (122°F) (no condensation)									
Accuracy	Working range			Uni-direction: 3 to 100% F.S., bi-direction: -100 to -3% F.S., 3 to 100% F.S.									
	Linearity (analog output)			Within ±3% F.S. (Secondary side released to atmosphere)									
	Pressure characteristics			Within ±5% F.S. (-0.09 (≈-13 psi) to 0.7 MPa (≈100 psi), where secondary side is released to atmosphere)									
	Temperature characteristics			Within ±0.2% F.S./°C (15 (59°F) to 35°C (95°F), 25°C (77°F) reference)									
*3	Repeatability			Within ±1% F.S.									
	Response time			50 ms or less									
Display			Flow bar display										
Output	Analog output	*1	V	1 to 5 V voltage output 1 point (connecting load impedance 50 kΩ and over) *4									
			A	4 to 20 mA current output 1 point (connecting load impedance 0 to 300 Ω)									
Power supply voltage	*5	*1	V	12 to 24 VDC (10.8 to 26.4 V)									
			A	24 VDC (21.6 to 26.4 V)									
Current consumption		*6	50 mA or less										
Lead wire			φ3.7, AWG26 or equivalent x 4-conductor (connector connection), insulator outer diameter φ1.0										
Functions			Analog output, flow bar display, error display										
Mounting	Mounting orientation			Unrestricted in vertical/horizontal direction									
	Straight piping section			Not required									
Degree of protection			IEC standards IP40 or equivalent										
Protection circuit		*7	Power reverse connection protection										
EMC Directive			EN55011, EN61000-6-2, EN61000-4-2/3/4/6/8										
Weight (main body only)	*4	H04	Approx. 40 g										
		H06	Approx. 40 g										
		H08	Approx. 60 g										
		H10	Approx. 65 g										
		A15	Approx. 145 g										
Clean-room specifications	*5	P70	Anti-dust generation *8										
		P80	Oil free *9										

Display separated (stainless steel body) specifications

1 MPa = 10 bar



Descriptions		Display separated (stainless steel body) FSM2-A[*1][*2][*3]-[*4][*5]-[*6]										
		Full scale flow rate	005	010	020	050	100	200	500	101	201	
Flow rate range *1	*3	005	500 ml/min	●								
		010	1 l/min		●							
		020	2 l/min			●						
		050	5 l/min				●					
		100	10 l/min					●				
		200	20 l/min						●			
		500	50 l/min							●		
		101	100 l/min								●	
		201	200 l/min									●
Port size/ body material	*4	S06	Rc1/8 Stainless steel	●	●	●	●	●	●	(Not for CO ₂)		
		S08	Rc1/4 Stainless steel							●	●	
		SM5	M5 Stainless steel (custom order)	●	●	●	●	●	●	(Not for CO ₂)		●
Flow direction		*2	F	Uni-direction								
			R	Bi-direction								
Working conditions	Applicable fluid *2	*5	Blank	Clean air (JIS B 8392-1:2012 (ISO 8573-1:2010) [1:1:1 to 5:6:2]), compressed air (JIS B 8392-1:2012 (ISO 8573-1:2010) [1:1:1 to 1:6:2]), nitrogen gas								
			AR	Argon								
			C2	Carbon dioxide (CO ₂)								
	Max. working pressure		1.0 MPa (≈150 psi, 10 bar)									
	Min. working pressure		-0.09 MPa (≈-13 psi, -0.9 bar)									
Proof pressure		1.5 MPa (≈220 psi, 15 bar)										
Operating ambient temperature/humidity		0 (32°F) to 50°C (122°F), 90% RH or less										
Fluid temperature		0 (32°F) to 50°C (122°F) (no condensation)										
Accuracy	Working range		Uni-direction: 3 to 100% F.S., bi-direction: -100 to -3% F.S., 3 to 100% F.S.									
	Linearity (analog output)		Within ±3% F.S. (Secondary side released to atmosphere)									
	Pressure characteristics		Within ±5% F.S. (-0.09 (≈-13 psi) to 0.7 MPa (≈100 psi), where secondary side is released to atmosphere)									
	Temperature characteristics		Within ±0.2% F.S./°C (15 (59°F) to 35°C (95°F), 25°C (77°F) reference)									
*3	Repeatability		Within ±1% F.S.									
Response time		50 ms or less										
Display		Flow bar display										
Output	Analog output	*1	V	1 to 5 V voltage output 1 point (connecting load impedance 50 kΩ and over) *4								
			A	4 to 20 mA current output 1 point (connecting load impedance 0 to 300 Ω)								
Power supply voltage	*5	*1	V	12 to 24 VDC (10.8 to 26.4 V)								
			A	24 VDC (21.6 to 26.4 V)								
Current consumption		*6	50 mA or less									
Lead wire		φ3.7, AWG26 or equivalent x 4-conductor (connector connection), insulator outer diameter φ1.0										
Functions		Analog output, flow bar display, error display										
Installation	Mounting orientation		Unrestricted in vertical/horizontal direction									
	Straight piping section		Not required									
Degree of protection		IEC standards IP40 or equivalent										
Protection circuit		*7	Power reverse connection protection									
EMC Directive		EN55011, EN61000-6-2, EN61000-4-2/3/4/6/8										
Weight (main body only)	*4	S06	Approx. 85 g									
		S08	Approx. 105 g									
		SM5	Approx. 130 g									
Clean-room specifications	*6	P70	Anti-dust generation *8									
		P80	Oil free *9									

*1: The value converted to volumetric flow rate at standard condition (20°C 1 barometric pressure (101 kPa) relative humidity 65%)
 *2: Use dry gas which does not contain corrosive elements such as chlorine, sulfur or acids, and which is clean and does not contain dust or oil mist. When using compressed air, use clean air compliant with JIS B8392-1: 2012 Grade [1:1:1 to 1:6:2]. Compressed air from the compressor contains drainage (water, oil oxides, foreign matter, etc.). To maintain the function of this product, install a filter, air dryer (min. pressure dew point 10°C or less), and oil mist filter (max. oil content 0.1 mg/m³) on the primary side (upstream side) of this product.
 [Recommended circuit]

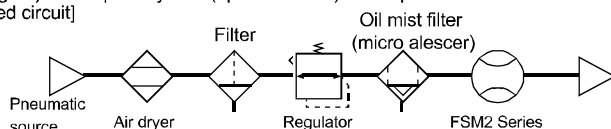

[Recommended device]
 Air filter: F series
 Oil mist filter: M series

*3: Calibration of this product is performed within specified range. Accuracy conditions: Temperature 25±3 °C, power supply voltage 24±0.01 VDC. F.S. stands for full scale flow rate.
 *4: The output impedance of the analog output section is approx. 1 kΩ. If the impedance of the connecting load is small, output and error increase. Check error with the impedance of the connecting load before using.
 *5: The power supply voltage specifications differ for the voltage output and current output.
 *6: Current for when 24 VDC is connected, and no load is applied. The current consumption will vary depending on how the load is connected.
 *7: This product's protection circuit is effective only for specific misconnections and load short-circuits. It does not provide protection for all misconnections.
 *8: [P70] Anti-dust generation (product surface is degreased and cleaned before packing. Heat sealed into antistatic bag in clean bench (Class 1000 and over).)
 *9: [P80] Oil-free (In addition to P70 specifications, gas-contact sections are degreased and cleaned. Refer to the "Internal structure and parts list" for details on the gas-contact materials.)

F.R.L
F (Filtr)
R (Reg)
L (Lub)
PresSW
Shutoff
SlowStart
FlnResistFR
Oil-ProhR
MedPresFR
No Cu/ PTFE FRL
Outdrs FR
F.R.L (Related)
CompFRL
LgFRL
PrecsR
VacF/R
Clean FR
ElecPneUR
AirBoost
SpdContr
Silncr
CheckV/ other
Jnt/tube
AirUnt
PresCompn
Mech/ ElecPresSW
ContactSW
AirSens
PresSW Cool
AirFloSens/ Contr
WaterPtSens
TotAirSys (Total Air)
TotAirSys (Gamma)
RefrDry
DesicDry
HiPolymDry
MainFiltr
Dischrg etc
Ending

F.R.L Separated display specifications

Descriptions				Separated display FSM2-D-[*1][*2]- □ -[*3]	
Settable flow rate range	*1	mℓ	5, 10, 50, 100, 500		
		ℓ	1, 2, 4, 5, 10, 12, 20, 25, 32, 50, 100, 200, 500, 1000, 1500		
Operating ambient temperature/humidity	0 (32°F) to 50°C (122°F)				
Display	4 digit + 4 digit 2 color LCD				
Input voltage	1 to 5 V				
Output	Switch output	*1	N	Output 2 points (NPN open collector output, 50 mA or less, voltage drop 2.4 V or less)	
			P	Output 2 points (PNP open collector output, 50 mA or less, voltage drop 2.4 V or less)	
Analog output	*2	V	1 to 5 V voltage output 1 point (connecting load impedance 50 kΩ and over) *6		
		A	4 to 20 mA current output 1 point (connecting load impedance 0 to 300 Ω)		
Power supply voltage	*2	V	12 to 24 VDC (10.8 to 26.4 V)		
		A	24 VDC (21.6 to 26.4 V)		
Current consumption	*2	40 mA or less (when 24 VDC is connected, and no load is connected)			
Cable	φ3.7, AWG26 or equivalent x 5-conductor (connector connection), insulator outer diameter φ1.0				
Functions	Flow rate display, flow rate display peak hold, switch output, analog output				
Degree of protection	IEC standards IP40 or equivalent				
Protection circuit	*3	Power reverse connection protection			
EMC Directive	EN55011, EN61000-6-2, EN61000-4-2/3/4/6/8				
Accessory	1 sensor connection connector (e-con), conforming cable AWG24 to 26, insulator outer diameter φ1.0 to 1.2				
Weight (main body only)	Approx. 40 g				
Clean-room specifications	*4	*3	P70	Anti-dust generation	

- *1: The flow rate range, flow direction and gas type are automatically recognized only when the FSM2 display separated is connected. (Default state)
The FSM-H Series, FSM-V Series and WFK3000 Series flow rate ranges are supported in addition to the FSM2 Series, but automatic recognition is supported only with the FSM2 Series. Always set the product's flow rate range, flow direction and gas type before use.
The connectable flow rate ranges are shown in "Display by flow rate range" below.
When the sensor section is changed, the previous flow rate range settings, etc., will still be recorded. Always reset the settings before using.
- *2: Current for when 24 VDC is connected, and no load is connected. The current consumption will vary depending on how the load is connected.
- *3: This product's protection circuit is effective only for specific misconnections and load short-circuits. It does not provide protection for all misconnections.
- *4: [P70] Anti-dust generation (product surface is degreased and cleaned before packing. Heat sealed into antistatic bag in clean bench (Class 1000 and over).)
- *5: When connecting to the FSM-V Series or WFK3000 Series, the cable size is different so a separate compatible sensor connection connector (e-con) will be required. Contact your nearest CKD sales office or dealer.
The enclosed sensor connection connector (e-con) can be used with the FSM Series and FSM-H Series.
- *6: The output impedance of the analog output section is approx. 1 kΩ. If the impedance of the connecting load is small, output and error increase. Check error with the impedance of the connecting load before using.

Display for each flow rate range

Flow rate display	Display range	Uni-direction	0 to 500 ml/min	0 to 1000 ml/min	0 to 2.00 ℓ/min	0 to 4.00 ℓ/min	0 to 5.00 ℓ/min	0 to 10.00 ℓ/min	0 to 12.0 ℓ/min	0 to 20.0 ℓ/min	0 to 25.0 ℓ/min	0 to 32.0 ℓ/min	0 to 50.0 ℓ/min	0 to 100.0 ℓ/min	0 to 200 ℓ/min	0 to 500 ℓ/min	0 to 1000 ℓ/min	0 to 1.50 m ³ /min	0 to 5.00 mℓ/min	0 to 10.00 mℓ/min	0 to 50.0 mℓ/min	0 to 100.0 mℓ/min
		Bi-direction	-500 to 500 mℓ/min	-1000 to 1000 mℓ/min	-2.00 to 2.00 ℓ/min	-	-5.00 to 5.00 ℓ/min	-10.00 to 10.00 ℓ/min	-	-20.0 to 20.0 ℓ/min	-	-	-50.0 to 50.0 ℓ/min	-100.0 to 100.0 ℓ/min	-200 to 200 ℓ/min	-500 to 500 ℓ/min	-1000 to 1000 ℓ/min	-1.50 to 1.50 m ³ /min	-5.00 to 5.00 mℓ/min	-10.00 to 10.00 mℓ/min	-50.0 to 50.0 mℓ/min	-100.0 to 100.0 mℓ/min
Display resolution			1 mℓ/min		0.01 ℓ/min			0.1 ℓ/min					1 ℓ/min		0.01 m ³ /min	0.01 mℓ/min	0.1 mℓ/min					
Display range			9999999 ml		99999.99 ℓ			999999.9 ℓ					9999999 ℓ		99999.99 m ³	99999.99 mℓ	999999.9 mℓ					
Display resolution			1 mℓ		0.01 ℓ			0.1 ℓ					1 ℓ		0.01 m ³	0.01 mℓ	0.1 mℓ					
Integrated pulse output rate			5 mℓ	10 mℓ	0.02 ℓ	0.04 ℓ	0.05 ℓ	0.1 ℓ	0.12 ℓ	0.2 ℓ	0.25 ℓ	0.32 ℓ	0.5 ℓ	1 ℓ	2 ℓ	5 ℓ	10 ℓ	15 ℓ	0.05 mℓ	0.1 mℓ	0.5 mℓ	1 mℓ

- *1: The flow rate display is rounded off at approx. ±1% F.S. or less (forced zero).
- *2: The integrating flow is a calculated (reference) value. It is reset when the power is turned OFF.
- * The corresponding sensor is the voltage output (1-5 V). If the current output or other voltage output is connected, it will not operate properly.

MEMO

F.R.L
F (Filtr)
R (Reg)
L (Lub)
PresSW
Shutoff
SlowStart
FmResistFR
Oil-ProhR
MedPresFR
No Cu/ PTFE FRL
Outdrs FR
F.R.L (Related)
CompFRL
LgFRL
PrecsR
VacF/R
Clean FR
ElecPneuR
AirBoost
SpdContr
Silncr
CheckV/ other
Jnt/tube
AirUnt
PresCompn
Mech/ ElecPresSw
ContactSW
AirSens
PresSW Cool
AirFloSens/ Contr
WaterPtSens
TotAirSys (Total Air)
TotAirSys (Gamma)
RefrDry
DesicDry
HiPolymDry
MainFiltr
Dischrg etc
Ending

How to order

● Display integrated, display separated, needle valve integrated

FSM2 - A V R 005 - S06 AR 1 B K N - P70

A Output

B Analog output
*2

C Flow direction

D Flow rate

E Port size
(body material)
*3

F Applicable fluid

G Cable

H Bracket

I Traceability

J With needle valve

K Clean-room specifications

* Refer to the table on the next page for the flow rate, port size (body material), and gas combinations.

[Example of model No.]

FSM2-NVF005-S06AR1BKN-P70

Model: RAPIFLOW FSM2

- A** Output : Display integrated (NPN)
- B** Analog output : Voltage output (1 to 5 V)
- C** Flow direction : Uni-direction
- D** Flow rate : 500 mℓ/min
- E** Port size (body material) : Rc 1/8 (stainless steel)
- F** Applicable fluid : Argon
- G** Cable : 1 m
- H** Bracket : With bracket
- I** Traceability : With company certification
- J** With needle valve : With needle valve
- K** Clean-room specifications : Anti-dust generation

⚠ Precautions for model No. selection

*1: For the **A** Output "A", the **H** Panel mounting option "P" cannot be selected.
The separated display is not enclosed with the Item **A** output "A".

*2: When using the FSM2-D for the separated display with the display separated, select "V".

*3: For the **E** Port size "A15", the **H** Panel mounting option "P" cannot be selected.

Code	Content
A Output	
A *1	External display (1 analog output)(Setting invalid for needle valve)
N	Integrated display (2 switch outputs (NPN), 1 analog output)
P	Integrated display (2 switch outputs (PNP), 1 analog output)
B Analog output	
V	Voltage output (1 to 5 V)
A	Current output (4 to 20 mA)
C Flow direction	
F	Uni-direction
R	Bi-direction (Setting not valid for type with needle valve)
D Flow rate (full scale flow rate)	
005	500 mℓ/min
010	1 ℓ/min
020	2 ℓ/min
050	5 ℓ/min
100	10 ℓ/min
200	20 ℓ/min
500	50 ℓ/min
101	100 ℓ/min
201	200 ℓ/min
501	500 ℓ/min (Setting invalid for needle valve)
102	1000 ℓ/min (Setting invalid for needle valve)
E Port size (body material)	
H04	Push-in φ4 (resin)
H06	Push-in φ6 (resin)
H08	Push-in φ8 (resin)
H10	Push-in φ10 (resin)
S06	Rc1/8 (stainless steel)
S08	Rc1/4 (stainless steel)
A15	Rc 1/2 (aluminum) (Setting invalid for needle valve)
SM5	M5 (stainless steel) (custom order product) (Setting invalid for needle valve)
F Applicable fluid	
Blank	Air, nitrogen gas
AR	Argon
C2	Carbon dioxide
G Cable	
Blank	None
1	1 m
3	3 m
H Bracket	
Blank	None
B	With bracket
P *1	Panel mounting kit
I Traceability	
Blank	None
T	Traceability with series variation diagram/company cert.
K	With company certification
J With needle valve	
Blank	None
N	Needle valve integrated
K Clean-room specifications	
Blank	None
P70	Anti-dust generation
P80	Oil free

- F.R.L
- F (Filtr)
- R (Reg)
- L (Lub)
- PresSW
- Shutoff
- SlowStart
- FlmResistFR
- Oil-ProhR
- MedPresFR
- No Cu/PTFE FRL
- Outdrs FR
- F.R.L (Related)
- CompFRL
- LgFRL
- PrecsR
- VacF/R
- Clean FR
- ElecPneuR
- AirBoost
- SpdContr
- SiIncr
- CheckV/other
- Jnt/tube
- AirUnt
- PrecsCompn
- Mech/ElecPresSw
- ContactSW
- AirSens
- PresSW Cool
- AirFloSens/Contr
- WaterRtSens
- TotAirSys (Total Air)
- TotAirSys (Gamma)
- RefrDry
- DesicDry
- HiPolymDry
- MainFiltr
- Dischrg etc
- Ending

Flow rate, port size (body material), and compatible needle valve combinations

D Flow rate		E Port size (body material)							
		H04	H06	H08	H10	S06	S08	A15	SM5
D	005	●◆	●◆			●○△◆			●○△
	010	●◆	●◆			●○△◆			●○△
	020	●◆	●◆			●○△◆			●○△
	050	●◆	●◆			●○△◆			●○△
	100	●◆	●◆			●○△◆			●○△
	200	●◆	●◆			●○△◆			●○
	500		●◆	●◆		●○◆	●○△◆		
	101			●◆	●◆		●○△◆		
	201			●◆	●◆		●◆		
	501							●	
	102							●	

- F Gas
- : Air, nitrogen gas
 - : Argon
 - △ : Carbon dioxide
 - : Not available
- J With needle valve
- ◆ : Needle valve integrated

Combination of port size and clean-room specifications

K Clean-room specifications	P70	E Port size (body material)							
		H04	H06	H08	H10	S06	S08	A15	SM5
	P70	●	●	●	●	●	●	●	●
	P80	●	●			●	●	●	●

- : Available
- : Not available

Discrete option model No.

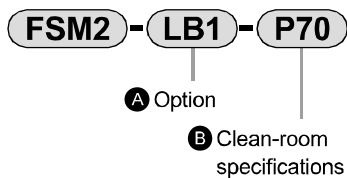

Code	Content
A Option	
LB1	Bracket (for φ4, φ6, φ8, φ10, Rc1/8, Rc1/4, M5)
LB2	Bracket (for Rc1/2)
KHS	Panel mounting kit (for display integrated, for separated display) *
KHS-N	Panel mounting kit (for needle valve integrated)
C51	5-conductor cable 1 m (integrated/non-integrated display)
C53	5-conductor cable 3 m (integrated/non-integrated display)
C41	4-conductor cable 1 m (for display separated)
C43	4-conductor cable 3 m (for display separated)

Code	Content
B Clean-room specifications	
Blank	None
P70	Anti-dust generation

* The panel mounting kit cannot be mounted on the FSM2-□-A15□.

● Separated display

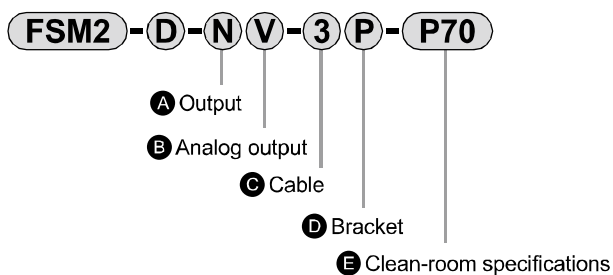

Discrete option model No.

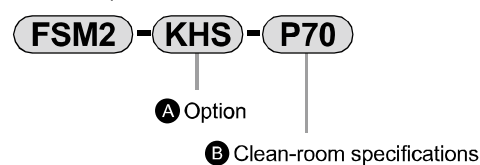

Code	Content
A Output	
N	Switch output (NPN) 2 points, analog output 1 point
P	Switch output (PNP) 2 points, analog output 1 point
B Analog output	
V	Voltage output (1 to 5 V)
A	Current output (4 to 20 mA)
C Cable	
Blank	None
1	1 m
3	3 m
D Bracket	
Blank	None
P	Panel mounting kit
E Clean-room specifications	
Blank	None
P70	Anti-dust generation

Code	Content
A Option	
KHS	Panel mounting kit set
C51	5-conductor cable 1 m (for display integrated, for separated display)
C53	5-conductor cable 3 m (for display integrated, for separated display)
EC	Sensor connection connector (e-con) 5pcs. set
B Clean-room specifications	
Blank	None
P70	Anti-dust generation



CAUTION The corresponding sensor is the voltage output (1-5 V). If the current output or other voltage output is connected, it doesn't operate properly. Use the FSM2-AV □ when using the FSM2.

F.R.L
F (Filtr)
R (Reg)
L (Lub)
PresSW
Shutoff
SlowStart
FmResistFR
Oil-ProhR
MedPresFR
No Cu/
PTFE FRL
Outdrs FR
F.R.L
(Related)
CompFRL
LgFRL
PrecsR
VacF/R
Clean FR
ElecPneuR
AirBoost
SpdContr
Silncr
CheckV/
other
Jnt/tube
AirUnt
PresCompn
Mech/
ElecPresSW
ContactSW
AirSens
PresSW
Cool
AirFloSens/
Contr
WaterPtSens
TotAirSys
(Total Air)
TotAirSys
(Gamma)
RefrDry
DesicDry
HiPolymDry
MainFiltr
Dischrg
etc
Ending

F.R.L
F (Filtr)
R (Reg)
L (Lub)
PresSW
Shutoff
SlowStart
FlmResistFR
Oil-ProhR
MedPresFR
No Cu/
PTFE FRL
Outdrs FR
F.R.L
(Related)
CompFRL
LgFRL
PrecsR
VacF/R
Clean FR
ElecPneuR
AirBoost
SpdContr
Silncr
CheckV/
other
Jnt/tube
AirUnt
PrecsCompn
Mech/
ElecPresSw
ContactSW
AirSens
PresSW
Cool
AirFloSens/
Contr
WaterRtSens
TotAirSys
(Total Air)
TotAirSys
(Gamma)
RefrDry
DesicDry
HiPolymDry
MainFiltr
Dischrg
etc
Ending

Internal structure and parts list

● Display integrated resin body port size $\phi 6$ push-in

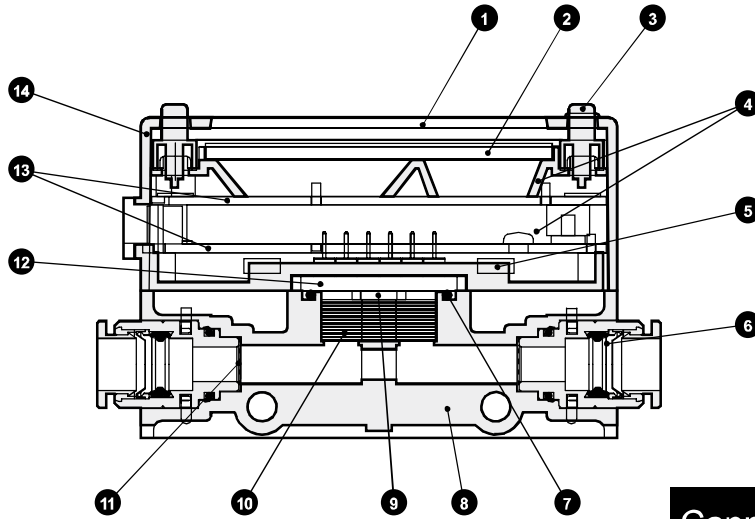

Cannot be disassembled

Main parts list

* The part materials are subject to change without notice.

No.	Part name	Material	No.	Part name	Material
1	Liquid crystal cover	Acrylic resin	8	Resin body (*)	Polyamide resin
2	Liquid crystal	-	9	Sensor chip (*)	Semiconductor chip
3	Switch	Ethylene/propylene diene rubber	10	Rectification plate (*)	Stainless steel
4	Base spacer	Polycarbonate resin	11	Port filter (*)	Stainless steel
5	Module holder	PPS resin	12	Sensor board (*)	Alumina
6	Push-in fitting	-	13	Electronic circuit board	-
7	Sensor gasket (*)	Fluoro rubber	14	Case	ABS resin

(*)...Cleaning parts for P80 specifications

● Display separated stainless steel body port size Rc1/4

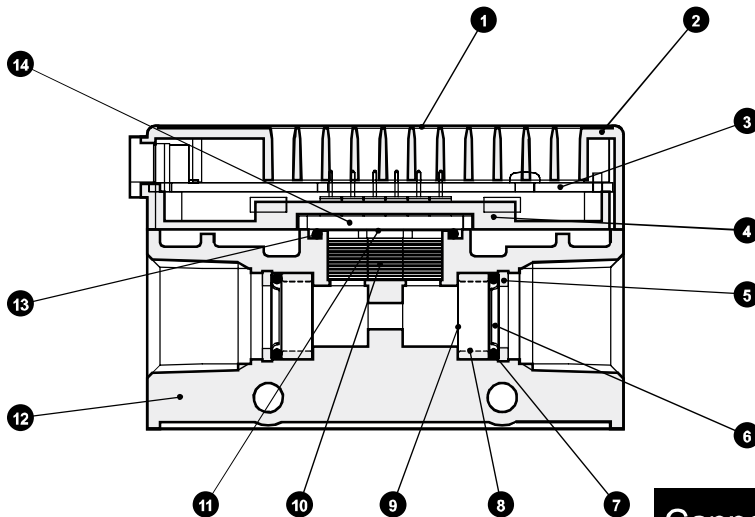

Cannot be disassembled

Main parts list

* The part materials are subject to change without notice.

No.	Part name	Material	No.	Part name	Material
1	Front sheet	Polyethylene film	8	Spacer (*)	Stainless steel
2	Case	ABS resin	9	Port filter (*)	Stainless steel
3	Electronic circuit board	-	10	Rectification plate (*)	Stainless steel
4	Module holder	PPS resin	11	Sensor chip (*)	Semiconductor chip
5	C-ring (*)	Stainless steel	12	Stainless steel body (*)	Stainless steel
6	O-ring holder (*)	Stainless steel	13	Sensor gasket (*)	Fluoro rubber
7	O-ring (*)	Fluoro rubber	14	Sensor board (*)	Alumina

(*)...Cleaning parts for P80 specifications

Internal structure and parts list

- Display separated aluminum body port size Rc1/2

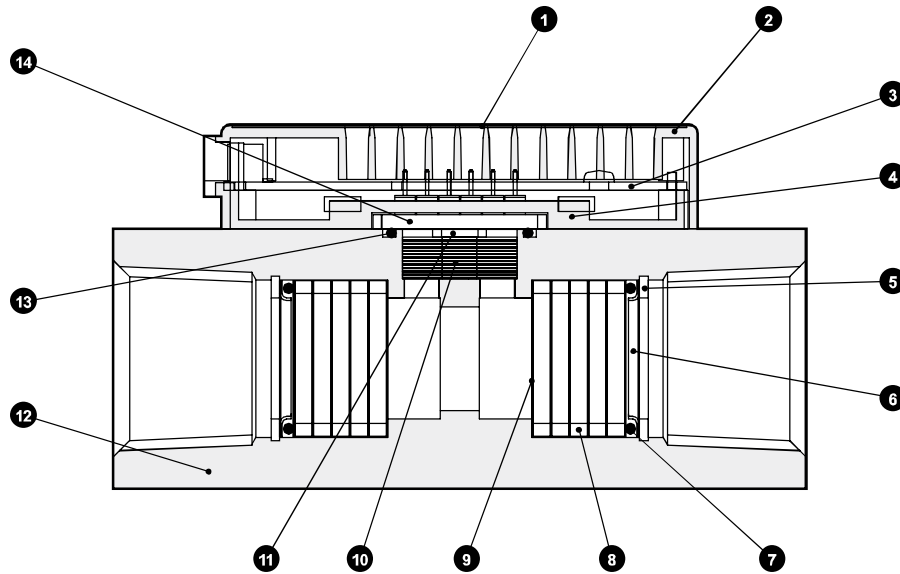

Cannot be disassembled

Main parts list

* The part materials are subject to change without notice.

No.	Part name	Material	No.	Part name	Material
1	Front sheet	Polyester film	8	Spacer (*)	Aluminum alloy
2	Case	ABS resin	9	Port filter (*)	Stainless steel
3	Electronic circuit board	-	10	Rectification plate (*)	Stainless steel
4	Module holder	PPS resin	11	Sensor chip (*)	Semiconductor chip
5	C-ring (*)	Stainless steel	12	Aluminum body (*)	Aluminum
6	O-ring holder (*)	Stainless steel	13	Sensor gasket (*)	Fluoro rubber
7	O-ring (*)	Fluoro rubber	14	Sensor board (*)	Alumina

(*)...Cleaning parts for P80 specifications

F.R.L
F (Filtr)
R (Reg)
L (Lub)
PresSW
Shutoff
SlowStart
FmResistFR
Oil-ProhR
MedPresFR
No Cu/ PTFE FRL
Outdrs FR
F.R.L (Related)
CompFRL
LgFRL
PrecsR
VacF/R
Clean FR
ElecPneuR
AirBoost
SpdContr
Silncr
CheckV/ other
Jnt/tube
AirUnt
PresCompn
Mech/ ElecPresSw
ContactSW
AirSens
PresSW Cool
AirFloSens/ Contr
WaterPtSens
TotAirSys (Total Air)
TotAirSys (Gamma)
RefrDry
DesicDry
HiPolymDry
MainFiltr
Dischrg etc
Ending

F.R.L
F (Filtr)
R (Reg)
L (Lub)
PresSW
Shutoff
SlowStart
FlmResistFR
Oil-ProhR
MedPresFR
No Cu/
PTFE FRL
Ouidrs FR
F.R.L
(Related)
CompFRL
LgFRL
PrecsR
VacF/R
Clean FR
ElecPneuR
AirBoost
SpdContr
Silncr
CheckV/
other
Jnt/tube
AirUnt
PrecsCompn
Mech/
ElecPresSw
ContactSW
AirSens
PresSW
Cool
AirFloSens/
Contr
WaterRtSens
TotAirSys
(Total Air)
TotAirSys
(Gamma)
RefrDry
DesicDry
HiPolymDry
MainFiltr
Dischrg
etc
Ending

Internal structure and parts list

● With needle valve (resin body) FSM2-□-H□N

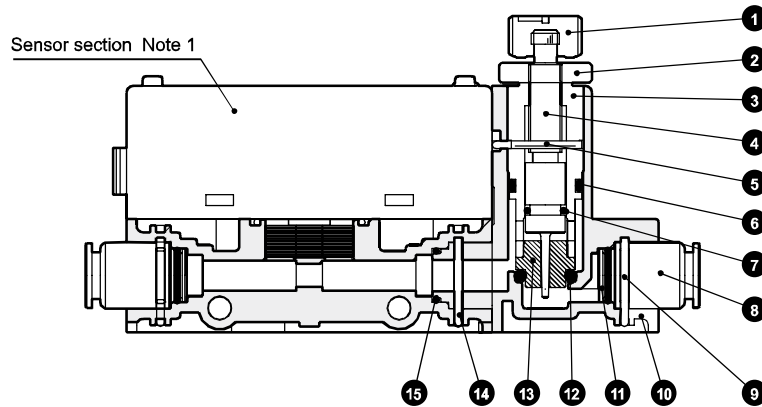

Cannot be disassembled

Main parts list

* The part materials are subject to change without notice.

No.	Part name	Material	No.	Part name	Material
1	Knob	Polybutylene terephthalate	9	Fitting fixing pin	Stainless steel
2	Lock nut	Copper alloy/nickeling	10	Needle valve body	Polyamide resin
3	Needle guide	Copper alloy/nickeling	11	Port filter	Stainless steel
4	Needle	Copper alloy/nickeling *2	12	O-ring	Fluoro rubber
5	Fixing pin	Stainless steel	13	Orifice	Copper alloy/nickeling *3
6	O-ring	Fluoro rubber (fluoro resin coating)	14	Fitting fixing pin	Stainless steel
7	O-ring	Fluoro rubber (fluoro resin coating)	15	O-ring	Fluoro rubber (fluoro resin coating)
8	Cartridge fitting	-			

*1: Refer to page 1246 for details on the sensor's main components.

*2: The needle is stainless steel for FSM2-□005/010/020.

*3: The orifice is PTFE for FSM2-□005/010/020.

● With needle valve (stainless steel body) FSM2-□-S□N

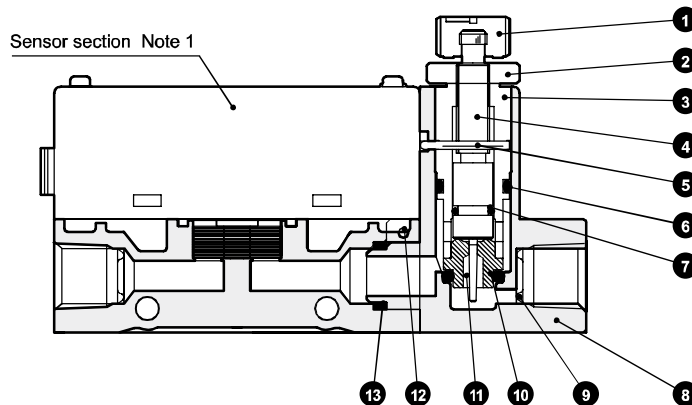

Cannot be disassembled

Main parts list

* The part materials are subject to change without notice.

No.	Part name	Material	No.	Part name	Material
1	Knob	Polybutylene terephthalate	8	Needle valve body	Stainless steel
2	Lock nut	Copper alloy/nickeling	9	Port filter	Stainless steel
3	Needle guide	Stainless steel	10	O-ring	Fluoro rubber
4	Needle	Stainless steel	11	Orifice	Tetra fluoro resin
5	Fixing pin	Stainless steel	12	Spring pin	Stainless steel
6	O-ring	Fluoro rubber (fluoro resin coating)	13	O-ring	Fluoro rubber (fluoro resin coating)
7	O-ring	Fluoro rubber (fluoro resin coating)			

*1: Refer to page 1246 for details on the sensor's main components.

Internal structure and parts list

- Separated display FSM2-D-□

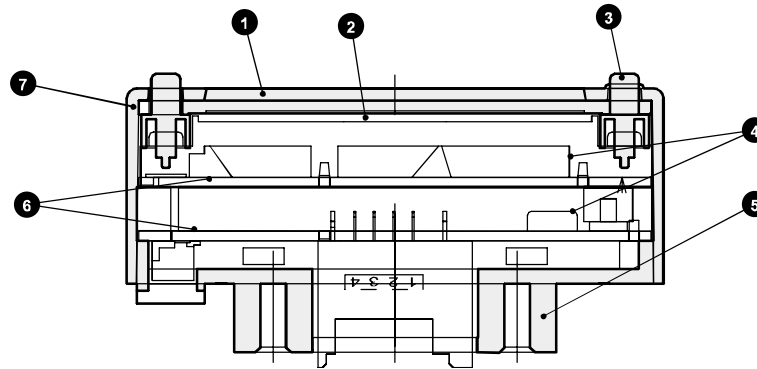

Cannot be disassembled

Main parts list

* The part materials are subject to change without notice.

No.	Part name	Material	No.	Part name	Material
1	Liquid crystal cover	Acrylic resin	5	Back surface cover	Polyamide resin
2	Liquid crystal	-	6	Electronic circuit board	-
3	Switch	Ethylene/propylene rubber	7	Case	ABS resin
4	Base spacer	Polycarbonate resin			

- F.R.L
- F (Filtr)
- R (Reg)
- L (Lub)
- PresSW
- Shutoff
- SlowStart
- FmResistFR
- Oil-ProhR
- MedPresFR
- No Cu/
PTFE FRL
- Outdrs FR
- F.R.L
(Related)
- CompFRL
- LgFRL
- PrescR
- VacF/R
- Clean FR
- ElecPneuR
- AirBoost
- SpdContr
- Silncr
- CheckV/
other
- Jnt/tube
- AirUnt
- PresCompn
- Mech/
ElecPresSw
- ContactSW
- AirSens
- PresSW
Cool
- AirFloSens/
Contr
- WaterPtSens
- TotAirSys
(Total Air)
- TotAirSys
(Gamma)
- RefrDry
- DesicDry
- HiPolymDry
- MainFiltr
- Dischrg
etc
- Ending



- F.R.L
- F (Filtr)
- R (Reg)
- L (Lub)
- PresSW
- Shutoff
- SlowStart
- FlmResistFR
- Oil-ProhR
- MedPresFR
- No Cu/
PTFE FRL
- Outdrs FR
- F.R.L
(Related)
- CompFRL
- LgFRL
- PrecsR
- VacF/R
- Clean FR
- ElecPneuR
- AirBoost
- SpdContr
- SiIncr
- CheckV/
other
- Jnt/tube
- AirUnt
- PrecsCompn
- Mech/
ElecPresSw
- ContactSW
- AirSens
- PresSW
Cool
- AirFloSens/
Contr
- WaterRtSens
- TotAirSys
(Total Air)
- TotAirSys
(Gamma)
- RefrDry
- DesicDry
- HiPolymDry
- MainFiltr
- Dischrg
etc
- Ending

Dimensions (display integrated)

Display integrated, port size: push-in $\phi 4$, $\phi 6$

● FSM2-N/P □ -H04/H06 □ (full scale flow rate: 0.5, 1, 2, 5, 10, 20, 50 l/min)

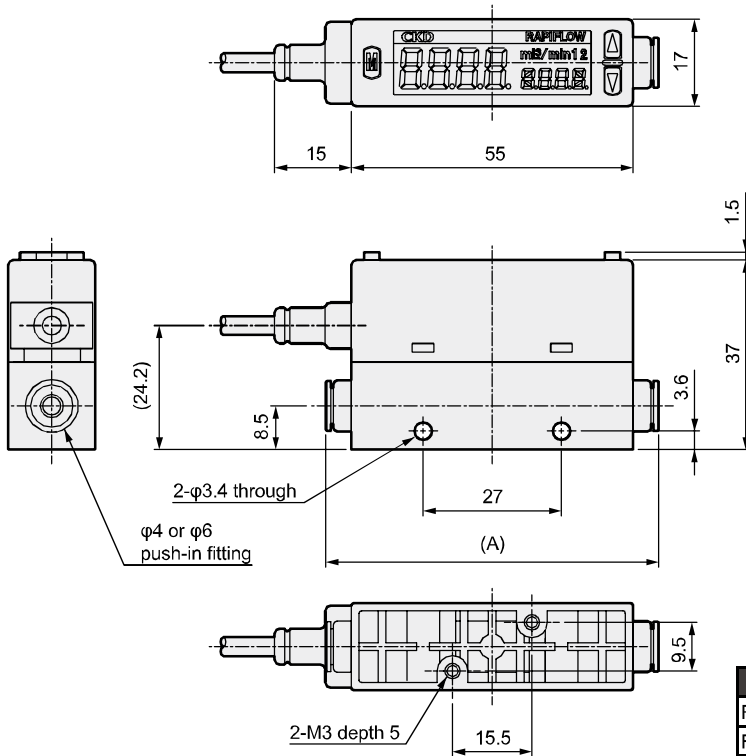

Model No.	Fitting	Dimension (A)
FSM2-N/P □ -H04 □	Push-in $\phi 4$	64.9
FSM2-N/P □ -H06 □	Push-in $\phi 6$	67.2

Display integrated, port size: push-in $\phi 8$, $\phi 10$

● FSM2-N/P □ -H08/H10 □ (full scale flow rate: 50, 100, 200 l/min)

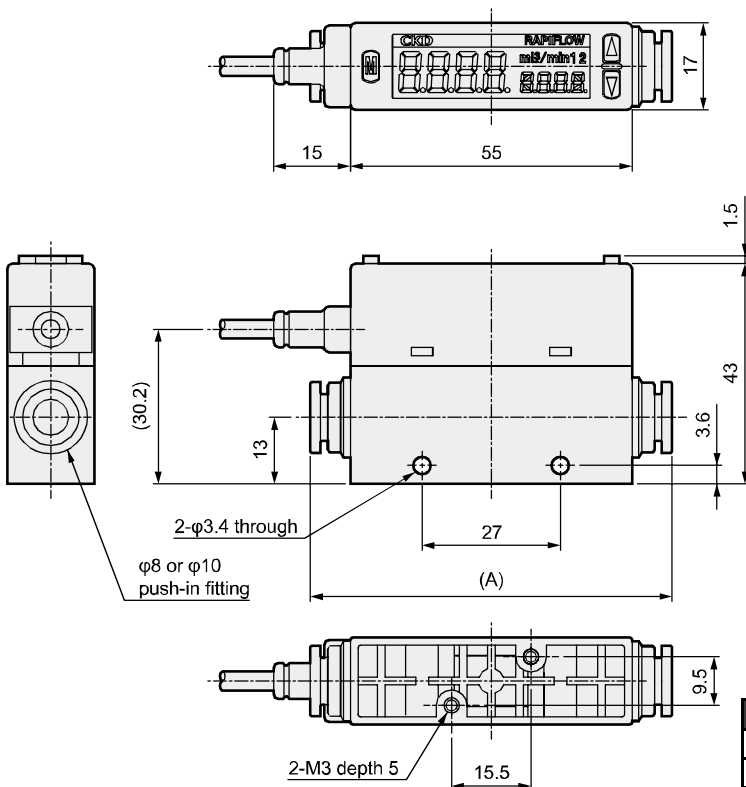

Model No.	Fitting	Dimension (A)
FSM2-N/P □ -H08 □	Push-in $\phi 8$	70.6
FSM2-N/P □ -H10 □	Push-in $\phi 10$	82.2

Dimensions (display integrated)



Display integrated, port size: Rc1/8, M5

- FSM2-N/P □ -S06/SM5 □ (full scale flow rate: 0.5, 1, 2, 5, 10, 20, 50 l/min)

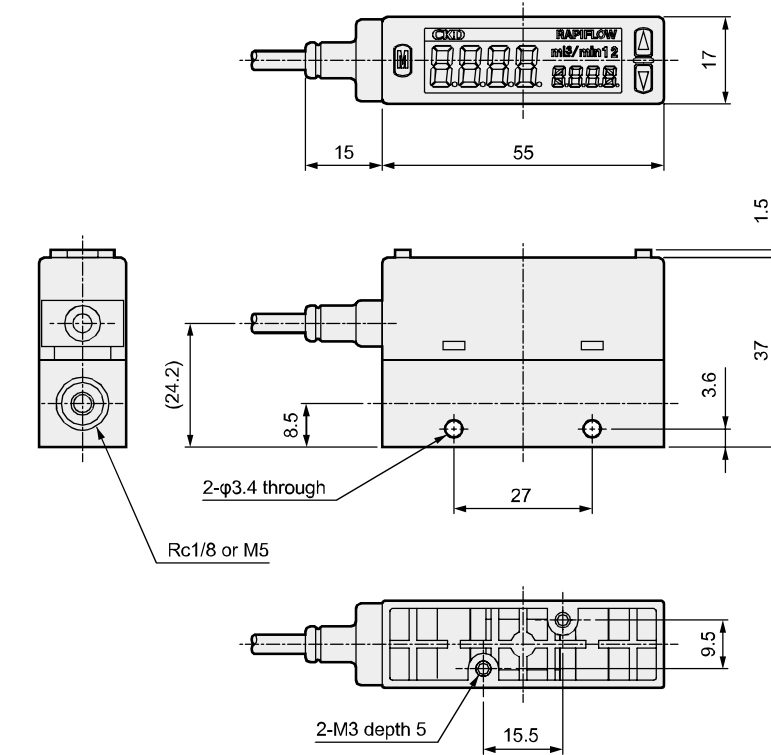

Display integrated, port size: Rc1/4

- FSM2-N/P □ -S08 □ (full scale flow rate: 50, 100, 200 l/min)

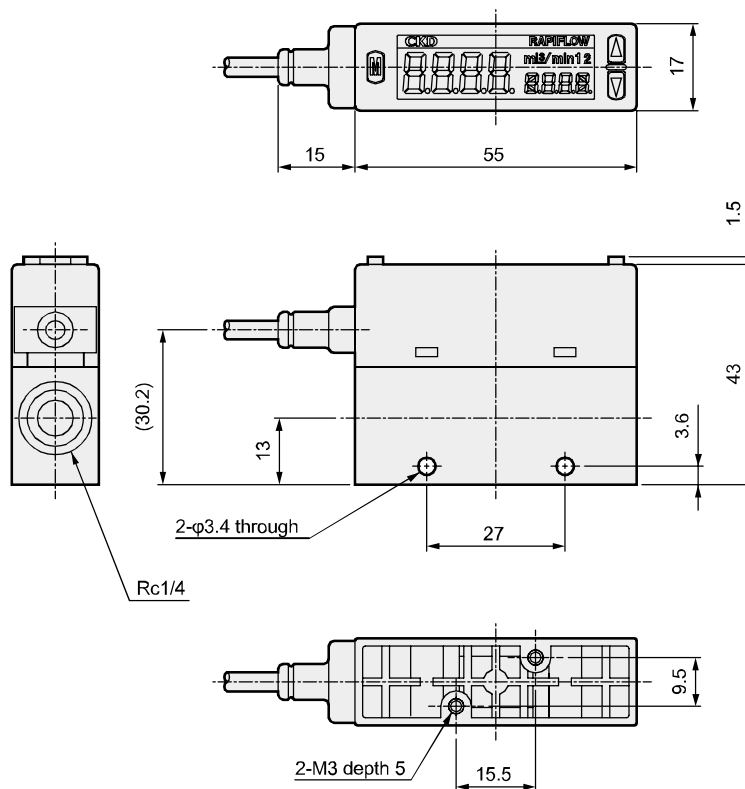

F.R.L
F (Filtr)
R (Reg)
L (Lub)
PresSW
Shutoff
SlowStart
FmResistFR
Oil-ProhR
MedPresFR
No Cu/ PTFE FRL
Outdrs FR
F.R.L (Related)
CompFRL
LgFRL
PrecsR
VacF/R
Clean FR
ElecPneuR
AirBoost
SpdContr
Silncr
CheckV/ other
Jnt/tube
AirUnt
PresCompn
Mech/ ElecPresSw
ContactSW
AirSens
PresSW Cool
AirFloSens/ Contr
WaterPtSens
TotAirSys (Total Air)
TotAirSys (Gamma)
RefrDry
DesicDry
HiPolymDry
MainFiltr
Dischrg etc
Ending

FSM2 Series



F.R.L Dimensions (display integrated)

F (Filtr) Display integrated, port size: Rc1/2

R (Reg) ● FSM2-N/P □ -A15 □ (full scale flow rate: 500, 1000 l/min)

L (Lub)

PresSW

Shutoff

SlowStart

FlmResistFR

Oil-ProhR

MedPresFR

No Cu/
PTFE FRL

Outdrs FR

F.R.L
(Related)

CompFRL

LgFRL

PrecsR

VacF/R

Clean FR

ElecPneuR

AirBoost

SpdContr

SiIncr

CheckV/
other

Jnt/tube

AirUnt

PrecsCompn

Mech/
ElecPresSw

ContactSW

AirSens

PresSW
Cool

AirFloSens/
Contr

WaterRtSens

TotAirSys
(Total Air)

TotAirSys
(Gamma)

RefrDry

DesicDry

HiPolymDry

MainFiltr

Dischrg
etc

Ending

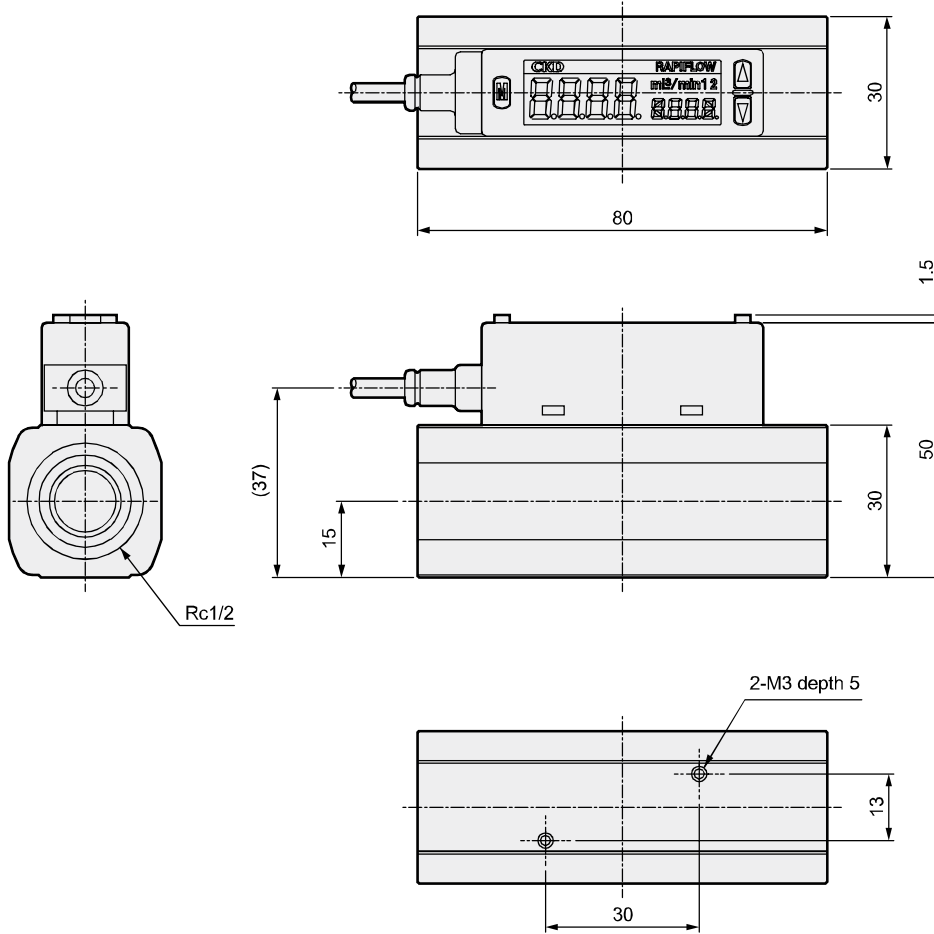

Dimensions (display separated)



Display separated, port size: push-in $\phi 4$, $\phi 6$

- FSM2-A □ -H04/H06 □ (full scale flow rate: 0.5, 1, 2, 5, 10, 20, 50 l/min)

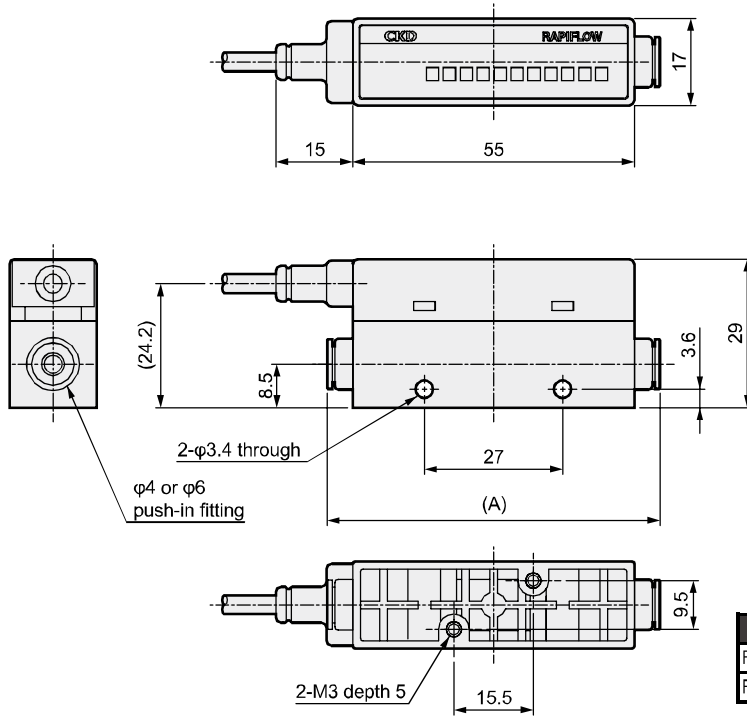

Model No.	Fitting	Dimension (A)
FSM2-A □ -H04 □	Push-in $\phi 4$	64.9
FSM2-A □ -H06 □	Push-in $\phi 6$	67.2

Display separated, port size: push-in $\phi 8$, $\phi 10$

- FSM2-A □ -H08/H10 □ (full scale flow rate: 50, 100, 200 l/min)

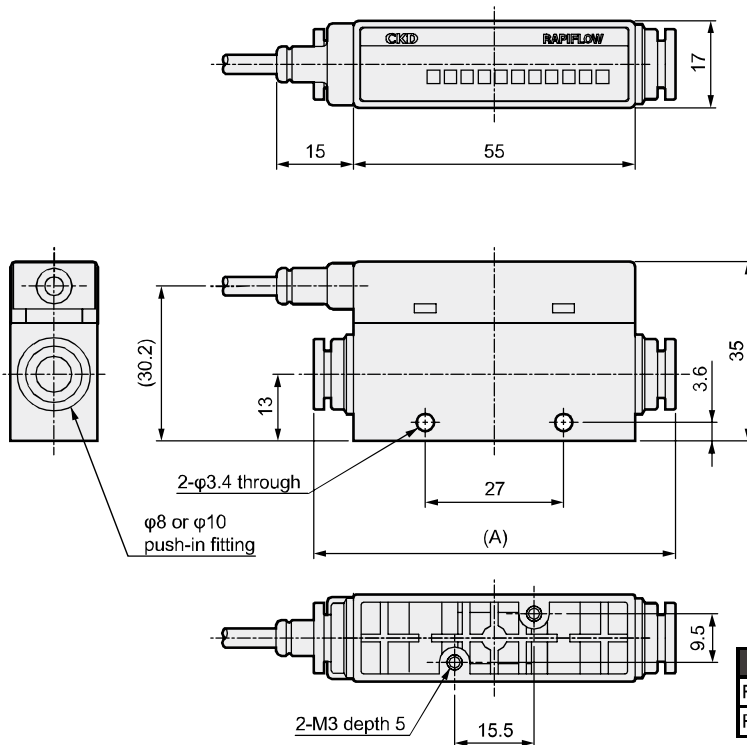

Model No.	Fitting	Dimension (A)
FSM2-A □ -H08 □	Push-in $\phi 8$	70.6
FSM2-A □ -H10 □	Push-in $\phi 15$	82.2

- F.R.L
- F (Filtr)
- R (Reg)
- L (Lub)
- PresSW
- Shutoff
- SlowStart
- PhiResistFR
- Oil-ProhR
- MedPresFR
- No Cu/PTFE FRL
- Outdrs FR
- F.R.L (Related)
- CompFRL
- LgFRL
- PrecsR
- VacF/R
- Clean FR
- ElecPneuR
- AirBoost
- SpdContr
- Silncr
- CheckV/other
- Jnt/tube
- AirUnt
- PresCompn
- Mech/ElecPresSw
- ContactSW
- AirSens
- PresSW Cool
- AirFloSens/Contr
- WaterPtSens
- TotAirSys (Total Air)
- TotAirSys (Gamma)
- RefrDry
- DesicDry
- HiPolymDry
- MainFiltr
- Dischrg etc
- Ending



F.R.L Dimensions (display separated)

F (Filtr) Display separated, port size: Rc1/8, M5

- FSM2-A □ -S06/SM5 □ (full scale flow rate: 0.5, 1, 2, 5, 10, 20, 50 l/min)

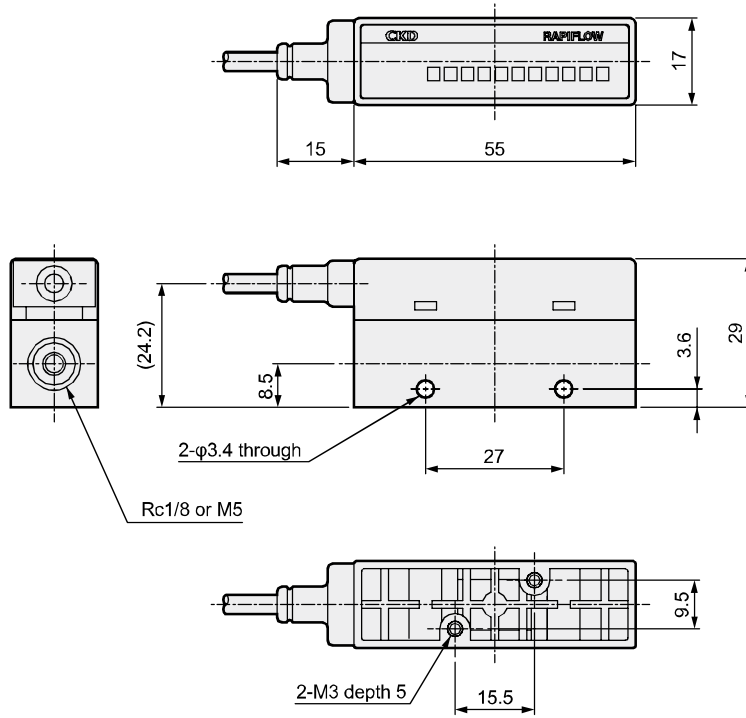

Display separated, port size: Rc1/4

- FSM2-A □ -S08 □ (full scale flow rate: 50, 100, 200 l/min)

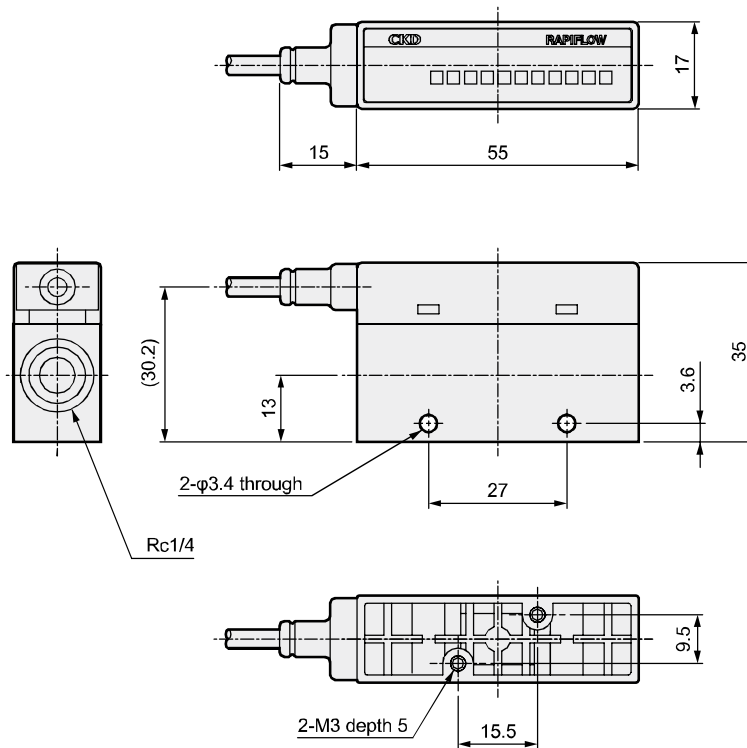

F.R.L
F (Filtr)
R (Reg)
L (Lub)
PresSW
Shutoff
SlowStart
FmResistFR
Oil-ProhR
MedPresFR
No Cu/ PTFE FRL
Outdrs FR
F.R.L (Related)
CompFRL
LgFRL
PrecsR
VacF/R
Clean FR
ElecPneuR
AirBoost
SpdContr
Silncr
CheckV/ other
Jnt/tube
AirUnt
PrecsCompn
Mech/ ElecPresSw
ContactSW
AirSens
PresSW Cool
AirFloSens/ Contr
WaterRtSens
TotAirSys (Total Air)
TotAirSys (Gamma)
RefrDry
DesicDry
HiPolymDry
MainFiltr
Dischrg etc
Ending

Dimensions (display separated)



Display separated, port size: Rc1/2

● FSM2-A □ -A15 □ (full scale flow rate: 500, 1000 l/min)

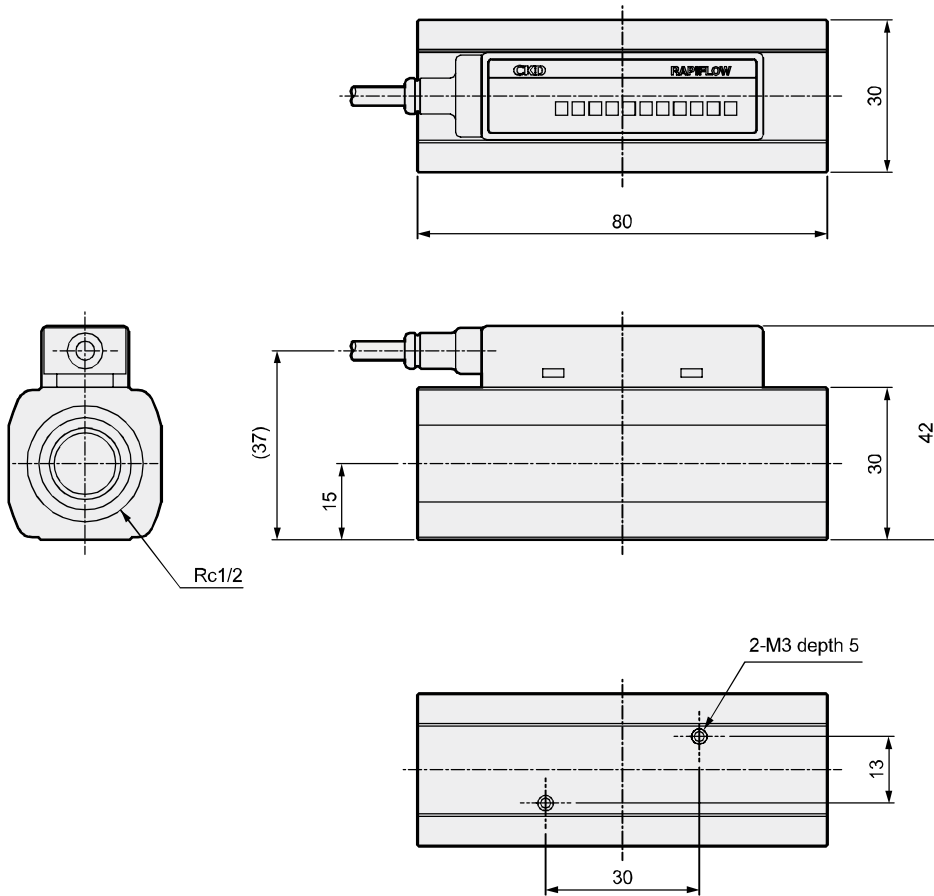

F.R.L
F (Filtr)
R (Reg)
L (Lub)
PresSW
Shutoff
SlowStart
FthResistFR
Oil-ProhR
MedPresFR
No Cu/ PTFE FRL
Outdrs FR
F.R.L (Related)
CompFRL
LgFRL
PrecsR
VacF/R
Clean FR
ElecPneuR
AirBoost
SpdContr
Silncr
CheckV/ other
Jnt/tube
AirUnt
PresCompn
Mech/ ElecPresSw
ContactSW
AirSens
PresSW Cool
AirFloSens/ Contr
WaterPtSens
TotAirSys (Total Air)
TotAirSys (Gamma)
RefrDry
DesicDry
HiPolymDry
MainFiltr
Dischrg etc
Ending



F.R.L Dimensions (display integrated, needle valve integrated)

- F (Filtr) Display integrated, port size: push-in $\phi 4$, $\phi 6$
- R (Reg) ● FSM2-N/P □ -H04/H06 □ N (full scale flow rate: 0.5, 1, 2, 5, 10, 20, 50 ℓ/min)

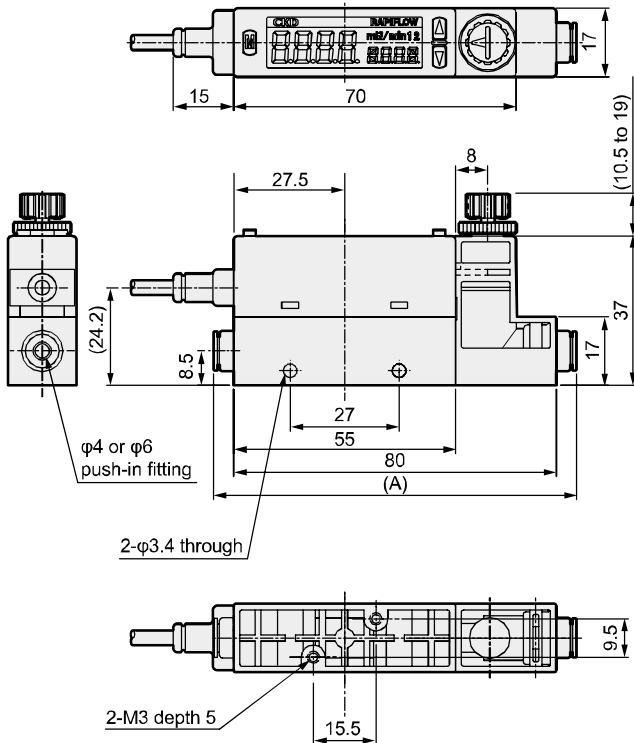

Model No.	Fitting	Dimension (A)
FSM2-N/P □ -H04 □	Push-in $\phi 4$	89.9
FSM2-N/P □ -H06 □	Push-in $\phi 6$	92.2

- Display integrated, port size: push-in $\phi 8$, $\phi 10$
- FSM2-N/P □ -H08/H10 □ N (full scale flow rate: 50, 100, 200 ℓ/min)

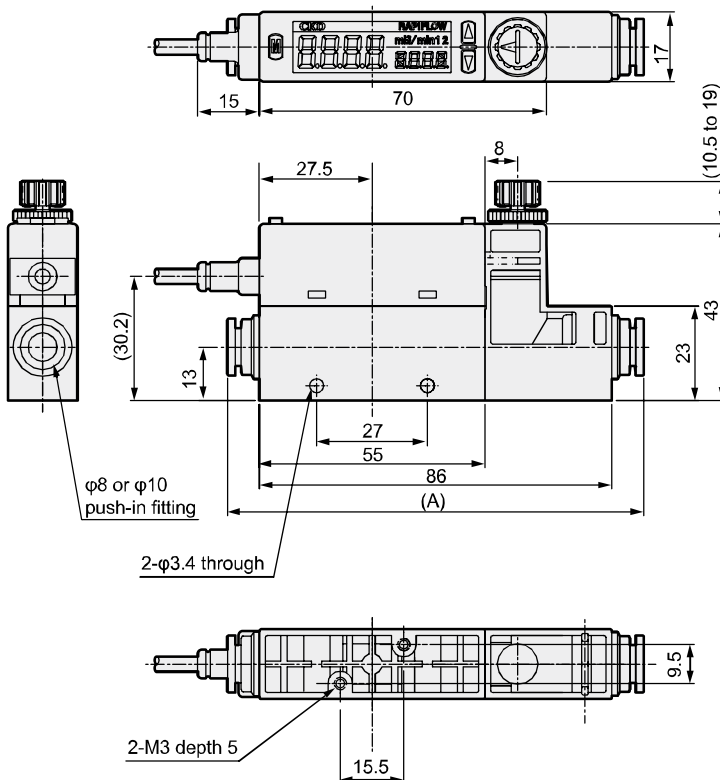

Model No.	Fitting	Dimension (A)
FSM2-N/P □ -H08 □	Push-in $\phi 8$	101.6
FSM2-N/P □ -H10 □	Push-in $\phi 10$	113.2



Dimensions (display integrated, needle valve integrated)

Display integrated, port size: Rc1/8

- FSM2-N/P □ -S06 □ N (full scale flow rate: 0.5, 1, 2, 5, 10, 20, 50 l/min)

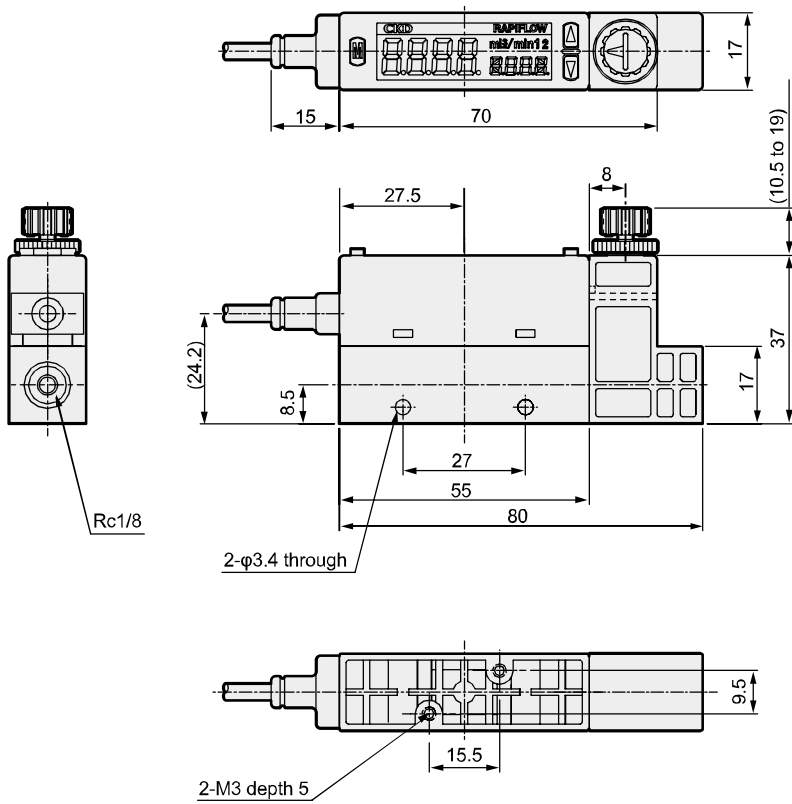

Display integrated, port size: Rc1/4

- FSM2-N/P □ -S08/ □ N (full scale flow rate: 50, 100, 200 l/min)

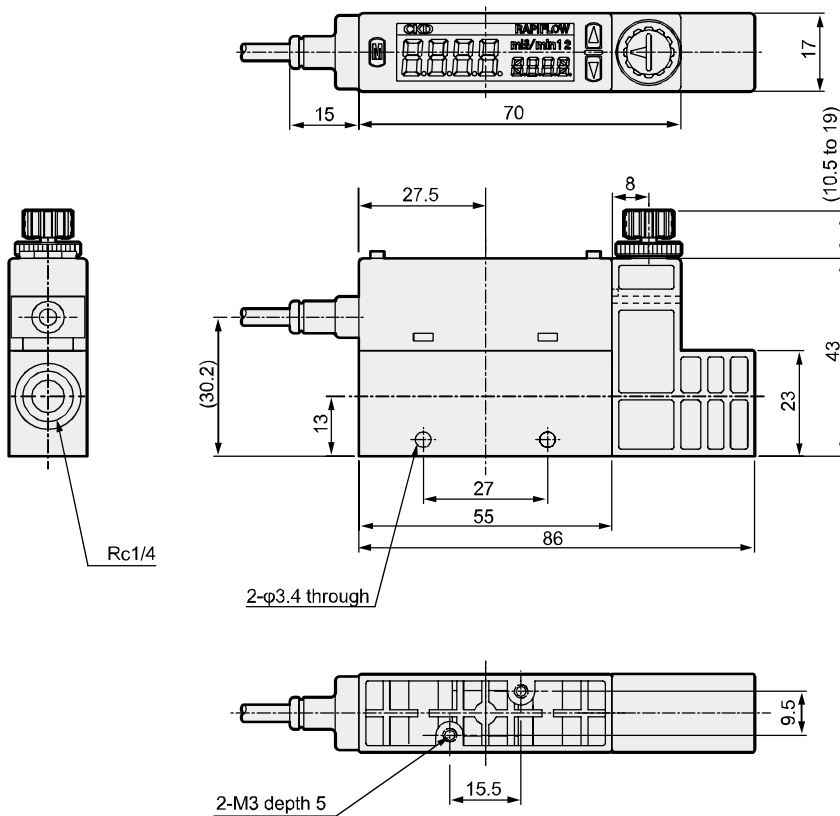

F.R.L
F (Filtr)
R (Reg)
L (Lub)
PresSW
Shutoff
SlowStart
FmResistFR
Oil-ProhR
MedPresFR
No Cu/ PTFE FRL
Outdrs FR
F.R.L (Related)
CompFRL
LgFRL
PrecsR
VacF/R
Clean FR
ElecPneuR
AirBoost
SpdContr
Silncr
CheckV/ other
Jnt/tube
AirUnt
PresCompn
Mech/ ElecPresSw
ContactSW
AirSens
PresSW Cool
AirFloSens/ Contr
WaterRtSens
TotAirSys (Total Air)
TotAirSys (Gamma)
RefrDry
DesicDry
HiPolymDry
MainFiltr
Dischrg etc
Ending



F.R.L
F (Filtr)
R (Reg)
L (Lub)
PresSW
Shutoff
SlowStart
FmResistFR
Oil-ProhR
MedPresFR
No Cu/ PTFE FRL
Outdrs FR
F.R.L (Related)
CompFRL
LgFRL
PrecsR
VacF/R
Clean FR
ElecPneuR
AirBoost
SpdContr
Silncr
CheckV/ other
Jnt/tube
AirUnt
PrecsCompn
Mech/ ElecPresSw
ContactSW
AirSens
PresSW Cool
AirFloSens/ Contr
WaterRtSens
TotAirSys (Total Air)
TotAirSys (Gamma)
RefrDry
DesicDry
HiPolymDry
MainFiltr
Dischrg etc
Ending

Dimensions with options (B: With bracket)

Display integrated, port size: push-in $\phi 4$, $\phi 6$, Rc1/8, M5

● FSM2-N/P □ -H04/H06/S06/SM5 □ B (full scale flow rate: 0.5, 1, 2, 5, 10, 20, 50 l/min)

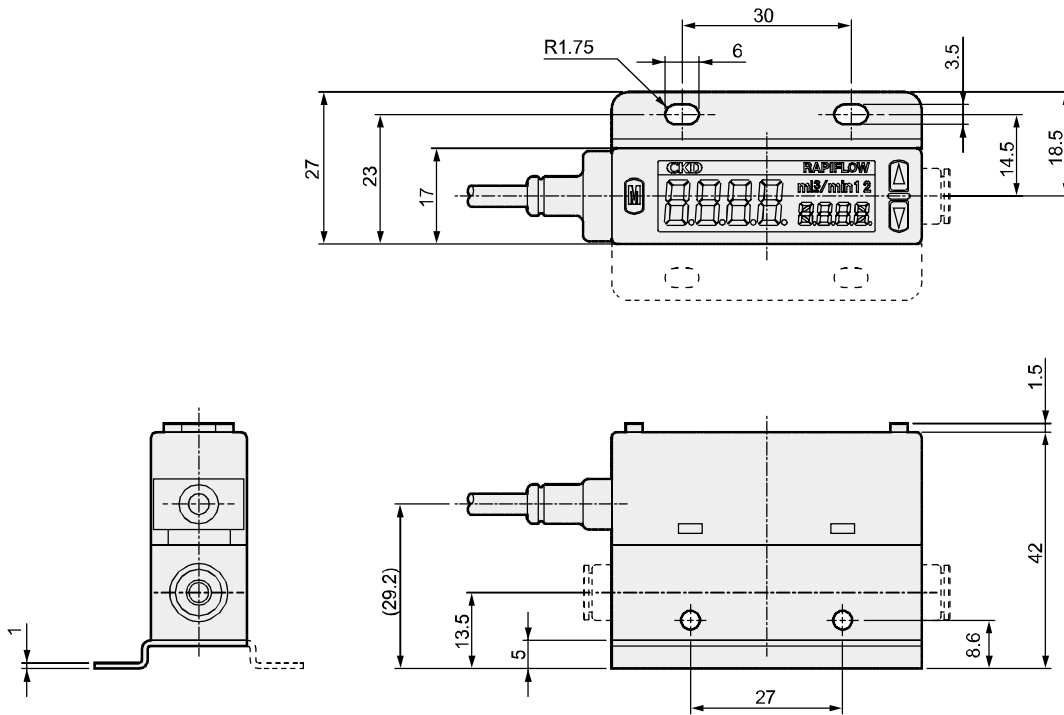

Display integrated, port size: push-in $\phi 8$, $\phi 10$, Rc1/4

● FSM2-N/P □ -H08/H10/S08 □ B (full scale flow rate: 50, 100, 200 l/min)

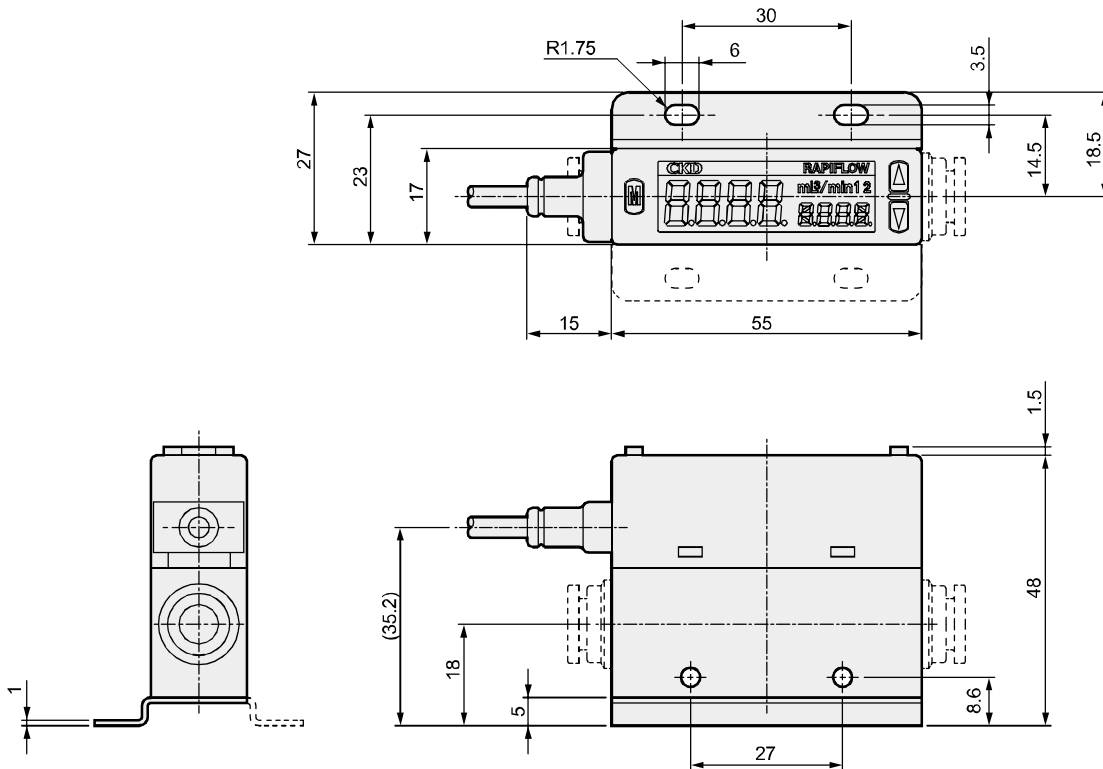

Dimensions with options (B: With bracket)



Display integrated, port size: Rc1/2

- FSM2-N/P □ -A15 □ B (full scale flow rate: 500, 1000 l/min)

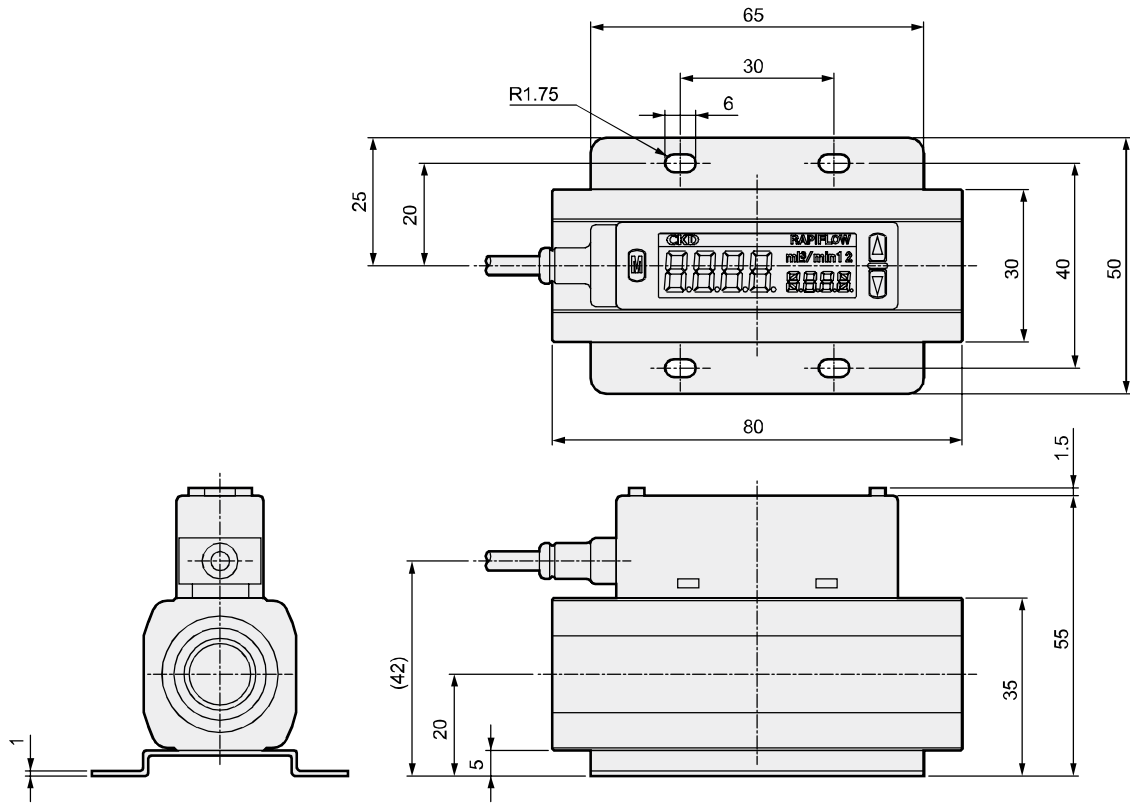

Display separated, port size: push-in $\phi 4$, $\phi 6$, Rc1/8, M5

- FSM2-A □ -H04/H06/S06/SM5 □ B (full scale flow rate: 0.5, 1, 2, 5, 10, 20, 50 l/min)

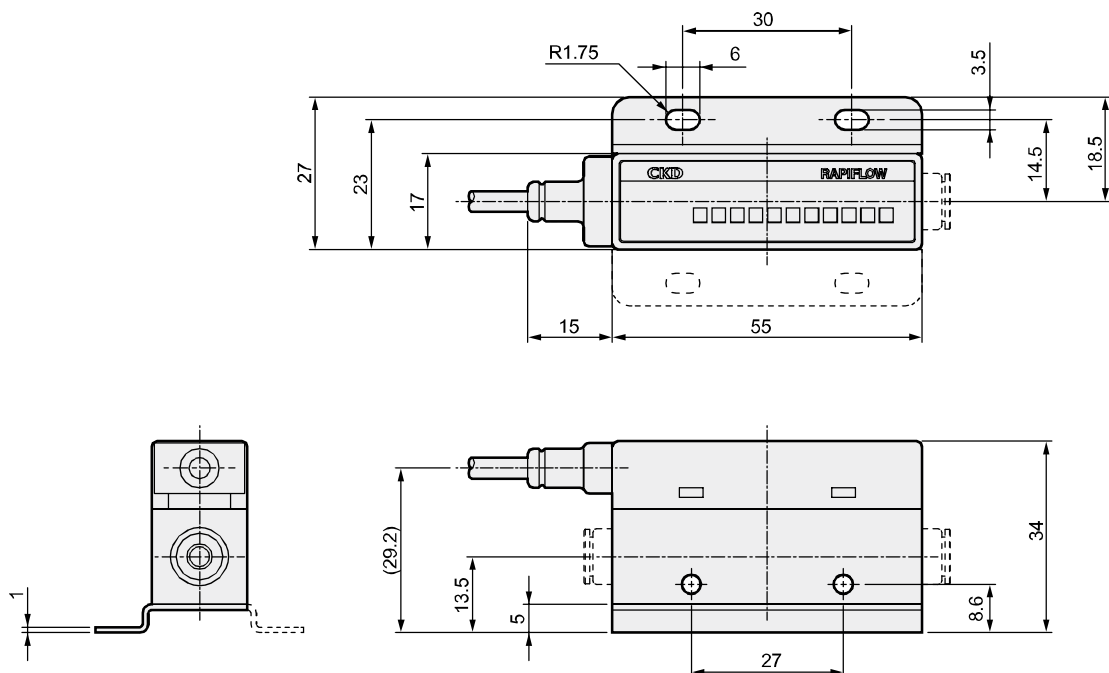

F.R.L
F (Filtr)
R (Reg)
L (Lub)
PresSW
Shutoff
SlowStart
FmResistFR
Oil-ProhR
MedPresFR
No Cu/ PTFE FRL
Outdrs FR
F.R.L (Related)
CompFRL
LgFRL
PrecsR
VacF/R
Clean FR
ElecPneuR
AirBoost
SpdContr
Silncr
CheckV/ other
Jnt/tube
AirUnt
PresCompn
Mech/ ElecPresSw
ContactSW
AirSens
PresSW Cool
AirFloSens/ Contr
WaterPtSens
TotAirSys (Total Air)
TotAirSys (Gamma)
RefrDry
DesicDry
HiPolymDry
MainFiltr
Dischrg etc
Ending



F.R.L
F (Filtr)
R (Reg)
L (Lub)
PresSW
Shutoff
SlowStart
FmResistFR
Oil-ProhR
MedPresFR
No Cu/ PTFE FRL
Outdrs FR
F.R.L (Related)
CompFRL
LgFRL
PrecsR
VacF/R
Clean FR
ElecPneuR
AirBoost
SpdContr
Silncr
CheckV/ other
Jnt/tube
AirUnt
PrecsCompn
Mech/ ElecPresSw
ContactSW
AirSens
PresSW Cool
AirFloSens/ Contr
WaterRtSens
TotAirSys (Total Air)
TotAirSys (Gamma)
RefrDry
DesicDry
HiPolymDry
MainFiltr
Dischrg etc
Ending

Dimensions with options (B: With bracket)

Display separated, port size: push-in $\phi 8$, $\phi 10$, Rc1/4

● FSM2-A -H08/H10/S08 B (full scale flow rate: 50, 100, 200 l/min)

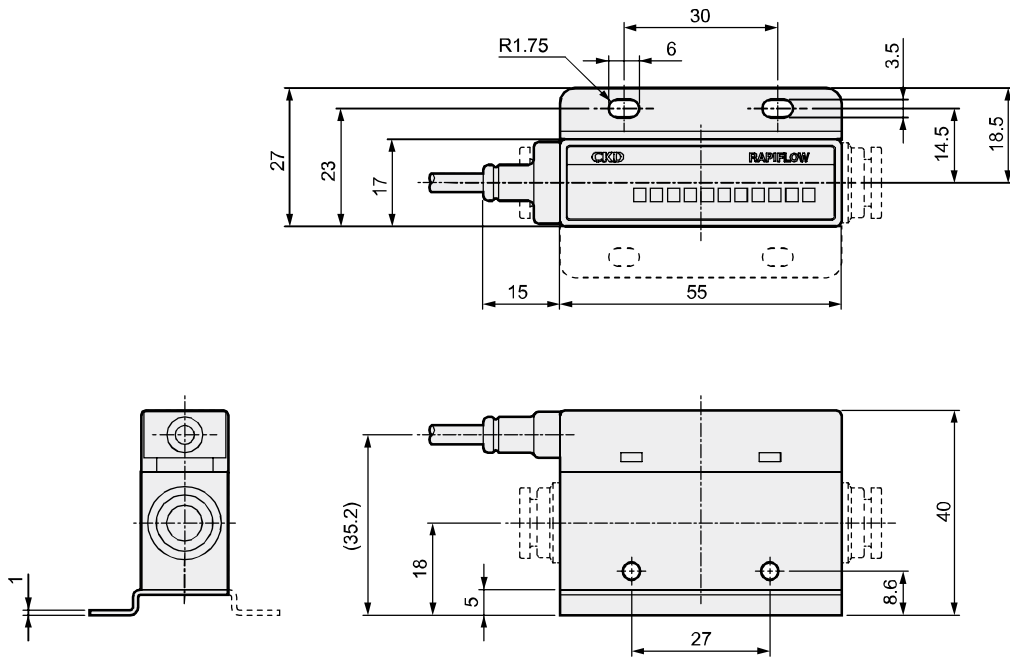

Display separated, port size: Rc1/2

● FSM2-A -A15 B (full scale flow rate: 500, 1000 l/min)

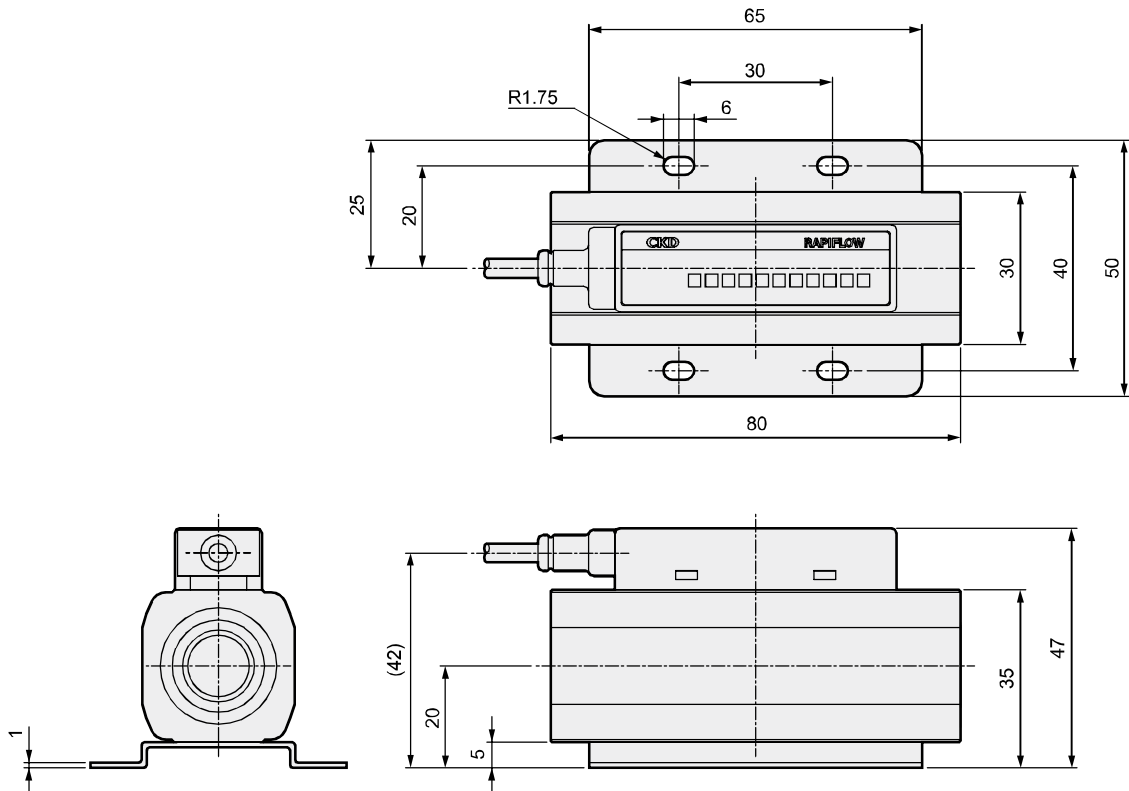

Dimensions with options (B: With bracket)



Needle valve integrated, port size: push-in $\phi 4$, $\phi 6$, Rc1/8

- FSM2-N/P □ -H04/H06/S06 □ BN (full scale flow rate: 0.5, 1, 2, 5, 10, 20, 50 l/min)

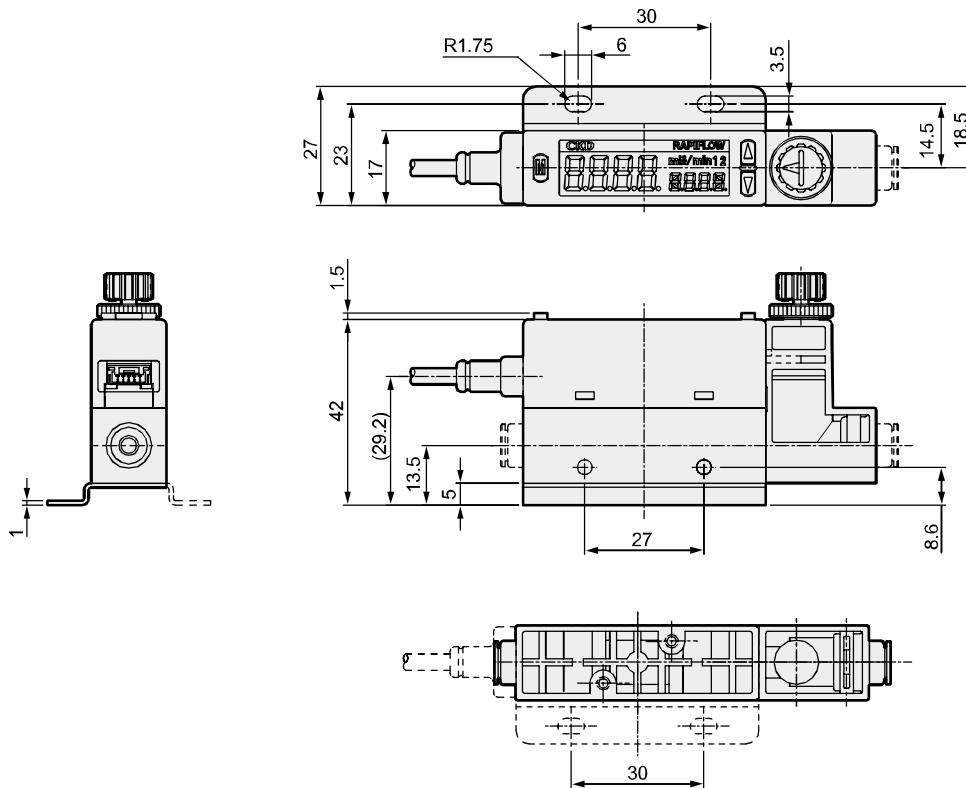

Needle valve integrated, port size: push-in $\phi 8$, $\phi 10$, Rc1/4

- FSM2-N/P □ -H08/H10/S08 □ BN (full scale flow rate: 50, 100, 200 l/min)

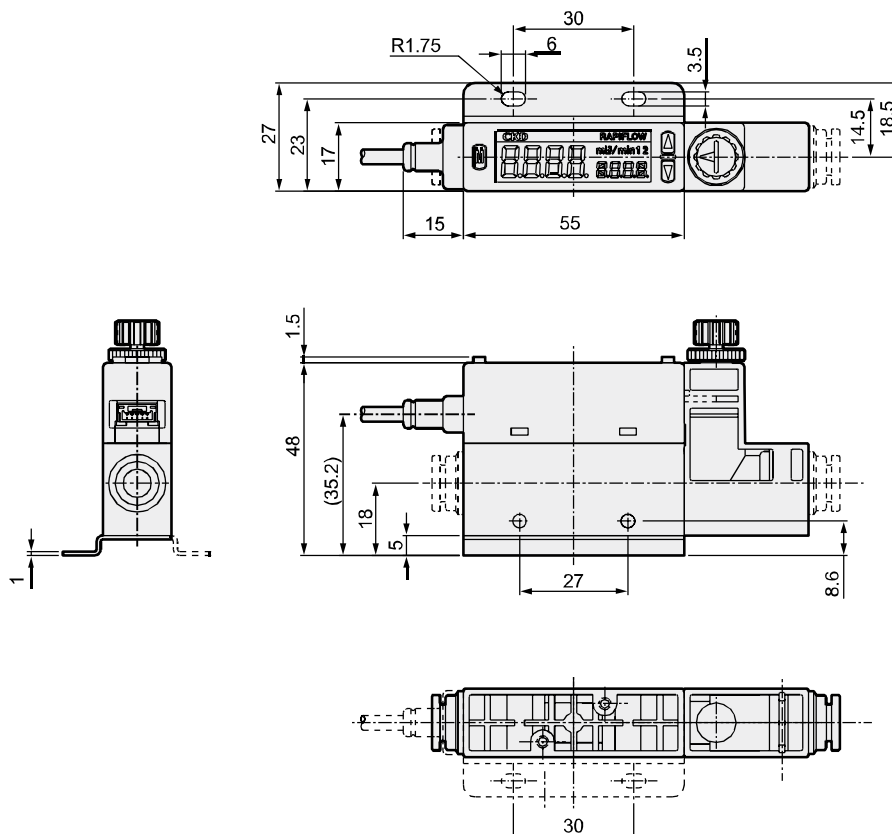

F.R.L
F (Filtr)
R (Reg)
L (Lub)
PresSW
Shutoff
SlowStart
FmResistFR
Oil-ProhR
MedPresFR
No Cu/ PTFE FRL
Outdrs FR
F.R.L (Related)
CompFRL
LgFRL
PrecsR
VacF/R
Clean FR
ElecPneuR
AirBoost
SpdContr
Silncr
CheckV/ other
Jnt/tube
AirUnt
PresCompn
Mech/ ElecPresSw
ContactSW
AirSens
PresSW Cool
AirFloSens/ Contr
WaterPtSens
TotAirSys (Total Air)
TotAirSys (Gamma)
RefrDry
DesicDry
HiPolymDry
MainFiltr
Dischrg etc
Ending



Dimensions with options (P: panel mounting kit with options)

● Display integrated

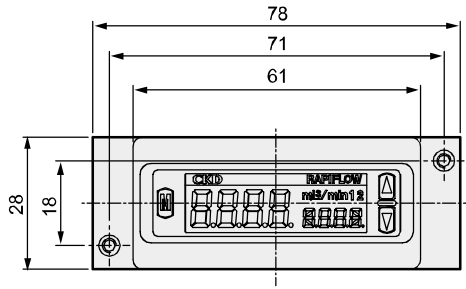

[Panel cut dimension]

In case of single installation

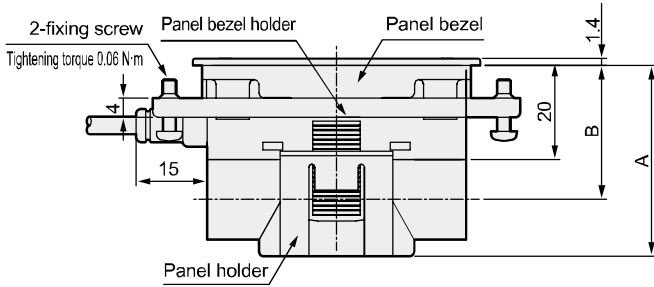
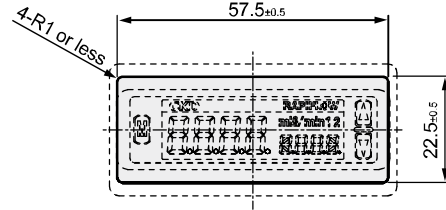

In case of continuous installation

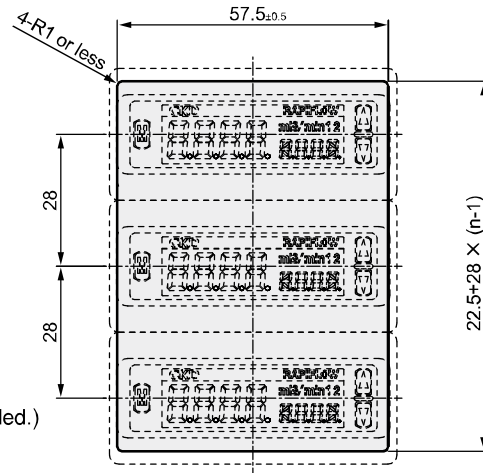

Panel thickness 6mm or less

Model No.	A	B
FSM2-N/P□-H04/H06/S06/SM5□	40.5	28.5
FSM2-N/P□-H08/H10/S08□	46.5	30.0

* Cannot be mounted on FSM-N/P□-A15□.

Weight: 23g
(Body is not included.)

● Needle valve integrated

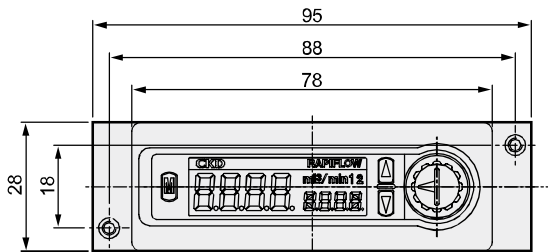

[Panel cut dimension]

In case of single installation

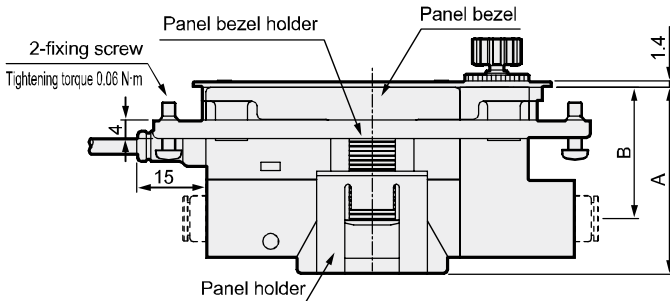
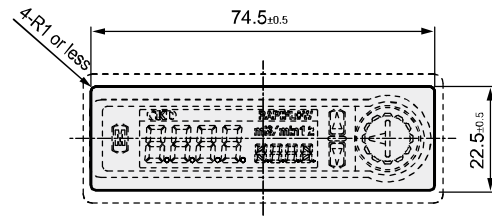

In case of continuous installation

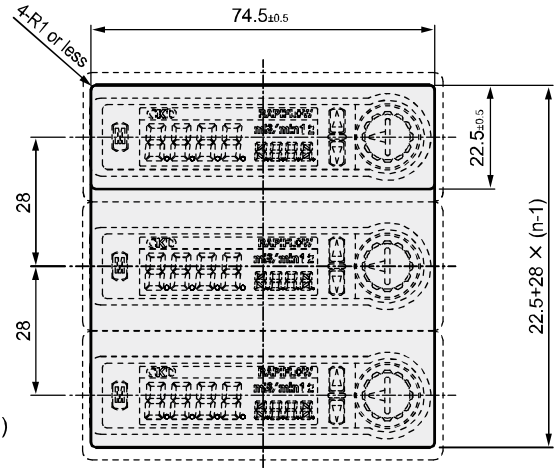

Panel thickness 6mm or less

Model No.	A	B
FSM2-N/P□-H04/H06/S06□N	40.5	28.5
FSM2-N/P□-H08/H10/S08□N	46.5	30.0

Weight: 25g
(Body is not included.)

Optional dimensions



● Bracket

Model No.: FSM2-LB1

(Full scale flow rate: 0.5, 1, 2, 5, 10, 20, 50, 100, 200 l/min)

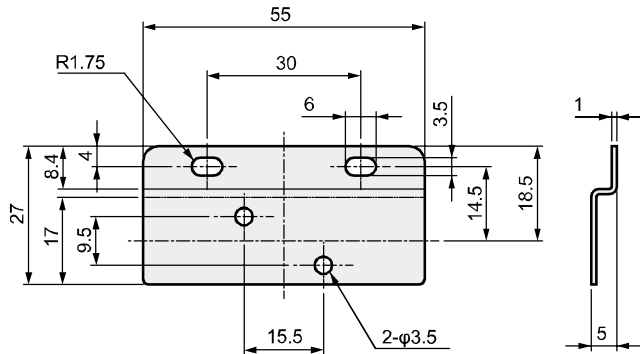

* 2 M3 fixing screws (length 6 mm) attached

Material: Steel
Weight: 13g

Model No.: FSM2-LB2

(Full scale flow rate: 500, 1000 l/min)

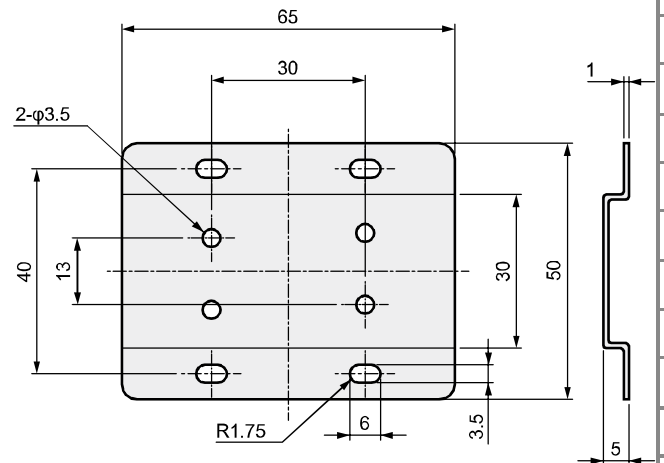

* 2 M3 fixing screws (length 6 mm) attached

Material: Steel
Weight: 28g

● Cable option

Model No.: FSM2-C51, C53

5-conductor cable (for display integrated FSM2-N/P □ - □ , for separated display FSM2-D)

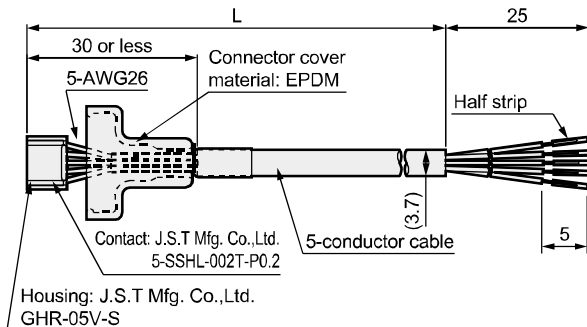

Terminal No.	Cable color
1	Brown
2	Black
3	White
4	Gray
5	Blue

Model No.	L dimensions	Weight g
FSM2-C51	1040±20	21
FSM2-C53	3040±20	57

Model No.: FSM2-C41, C43

4-conductor cable (for display separated FSM2-A □ - □)

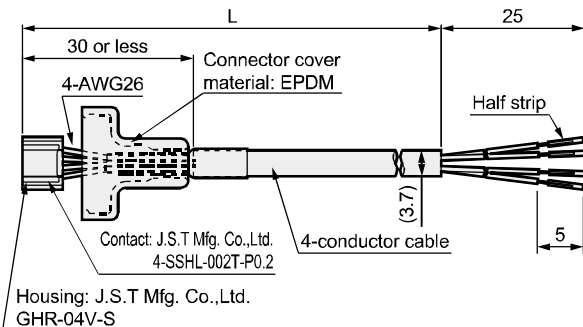

Terminal No.	Cable color
1	Brown
2	Black
3	White
4	Blue

Model No.	L dimensions	Weight g
FSM2-C41	1040±20	19
FSM2-C43	3040±20	52

F.R.L
F (Filtr)
R (Reg)
L (Lub)
PresSW
Shutoff
SlowStart
FhmResistFR
Oil-ProhR
MedPresFR
No Cu/ PTFE FRL
Outdrs FR
F.R.L (Related)
CompFRL
LgFRL
PrecsR
VacF/R
Clean FR
ElecPneuR
AirBoost
SpdContr
Silncr
CheckV/ other
Jnt/tube
AirUnt
PresCompn
Mech/ ElecPresSw
ContactSW
AirSens
PresSW Cool
AirFloSens/ Contr
WaterPtSens
TotAirSys (Total Air)
TotAirSys (Gamma)
RefrDry
DesicDry
HiPolymDry
MainFiltr
Dischrg etc
Ending



Separated display dimensions

F.R.L
F (Filtr)
R (Reg)
L (Lub)
PresSW
Shutoff
SlowStart
FlmResistFR
Oil-ProhR
MedPresFR
No Cu/ PTFE FRL
Outdrs FR
F.R.L (Related)
CompFRL
LgFRL
PrecsR
VacF/R
Clean FR
ElecPneuR
AirBoost
SpdContr
Silncr
CheckV/ other
Jnt/tube
AirUnt
PrecsCompn
Mech/ ElecPresSw
ContactSW
AirSens
PresSW Cool
AirFloSens/ Contr
WaterRtSens
TotAirSys (Total Air)
TotAirSys (Gamma)
RefrDry
DesicDry
HiPolymDry
MainFiltr
Dischrg etc
Ending

● FSM2-D-□

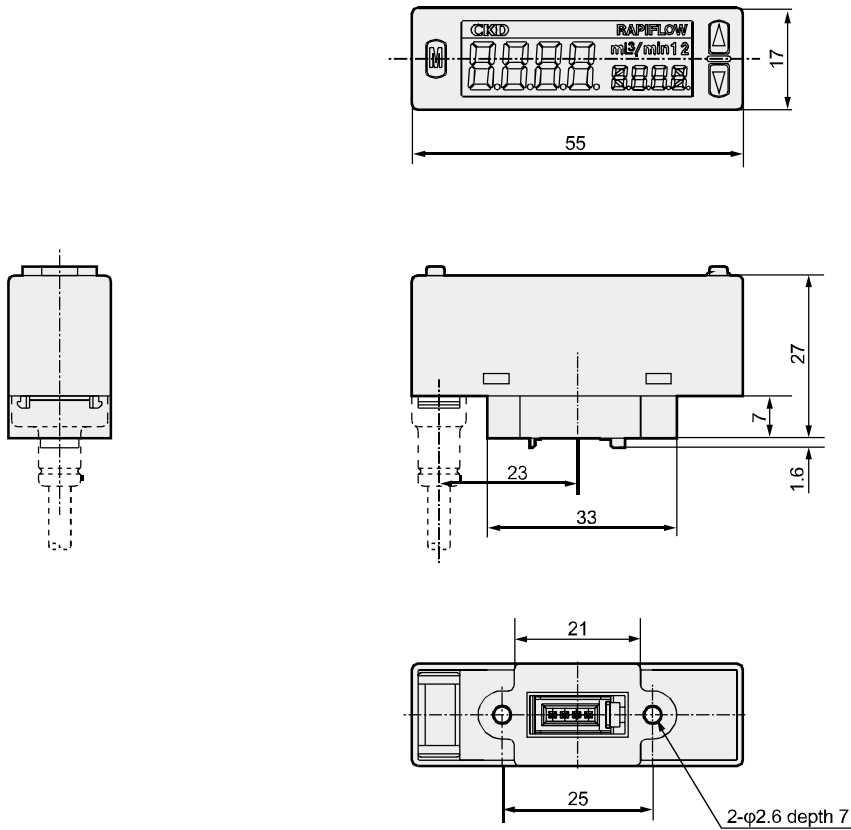

● Panel mounting kit with options dimensions

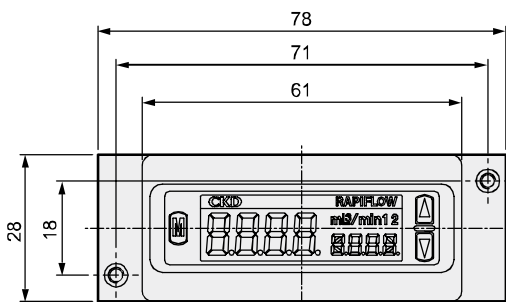

[Panel cut dimension]

In case of single installation

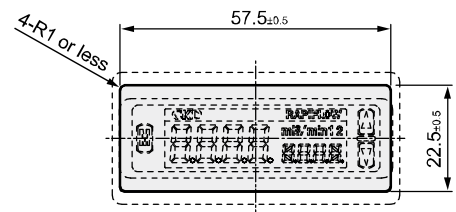

In case of continuous installation

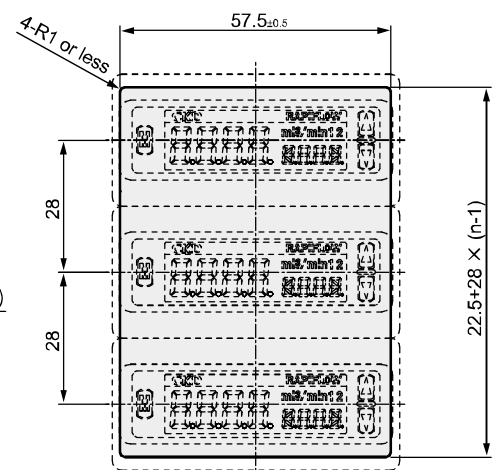

Panel thickness 6mm or less

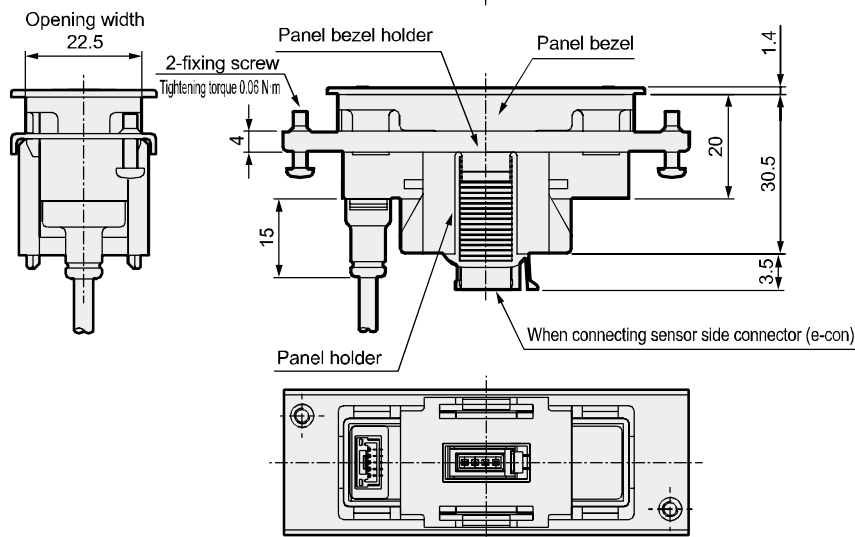

MEMO

F.R.L
F (Filtr)
R (Reg)
L (Lub)
PresSW
Shutoff
SlowStart
FmResistFR
Oil-ProhR
MedPresFR
No Cu/ PTFE FRL
Outdrs FR
F.R.L (Related)
CompFRL
LgFRL
PrecsR
VacF/R
Clean FR
ElecPneuR
AirBoost
SpdContr
Silncr
CheckV/ other
Jnt/tube
AirUnt
PresCompn
Mech/ ElecPresSw
ContactSW
AirSens
PresSW Cool
AirFloSens/ Contr
WaterPtSens
TotAirSys (Total Air)
TotAirSys (Gamma)
RefrDry
DesicDry
HiPolymDry
MainFiltr
Dischrg etc
Ending

- F.R.L
- F (Filtr)
- R (Reg)
- L (Lub)
- PresSW
- Shutoff
- SlowStart
- FlmResistFR
- Oil-ProhR
- MedPresFR
- No Cu/PTFE FRL
- Outdris FR
- F.R.L (Related)
- CompFRL
- LgFRL
- PrecsR
- VacF/R
- Clean FR
- ElecPneuR
- AirBoost
- SpdContr
- Silncr
- CheckV/other
- Jnt/tube
- AirUnt
- PrecsCompn
- Mech/ElecPresSw
- ContactSW
- AirSens
- PresSW Cool
- AirFloSens/Contr
- WaterRtSens
- TotAirSys (Total Air)
- TotAirSys (Gamma)
- RefrDry
- DesicDry
- HiPolymDry
- MainFiltr
- Dischrg etc
- Ending

Example of internal circuit and load connection

- FSM2-N □ - □ (display integrated NPN output)
- FSM2-D-N □ - □ (separated display NPN output)

[CH2 is used as SW output]

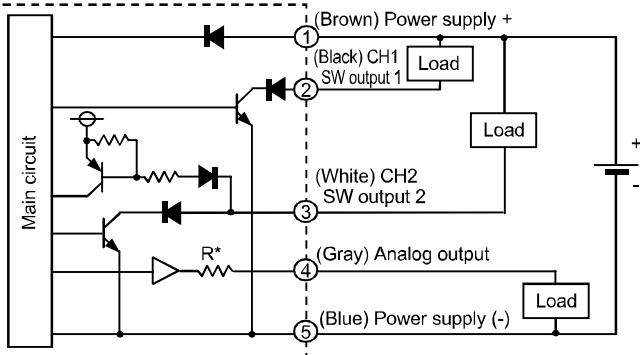

[CH2 is used as external input]

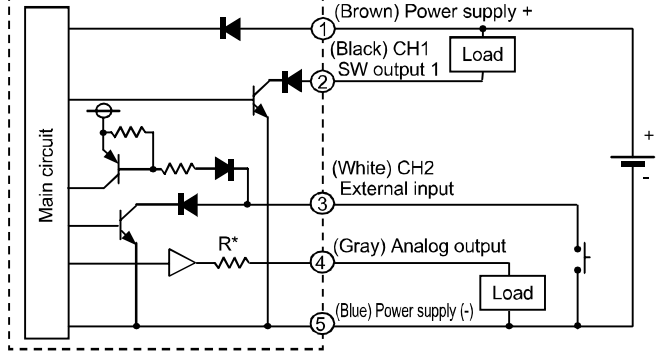

* Analog output: Voltage output R: approx. 1 kΩ
Current output R: approx. 100 Ω

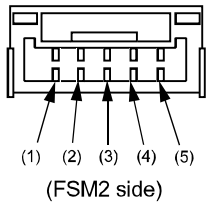

Terminal No.	Option cable color	Name
(1)	Brown	Power supply (+) (voltage output: 12 to 24 V, current output: 24 V)
(2)	Black	CH1 (Switch output 1: max. 50 mA)
(3)	White	CH2 (switch output 2: max. 50 mA, or external input)
(4)	Gray	Analog output Voltage output: 1 to 5 V load impedance 50 kΩ or more Current output: 4 to 20 mA load impedance 300 Ω or less
(5)	Blue	Power supply - (GND)

- FSM2-P □ - □ (display integrated PNP output)
- FSM2-D-P □ - □ (separated display PNP output)

[CH2 is used as SW output]

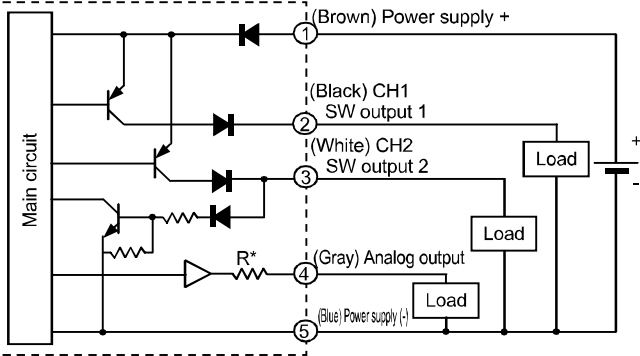

[CH2 is used as external input]

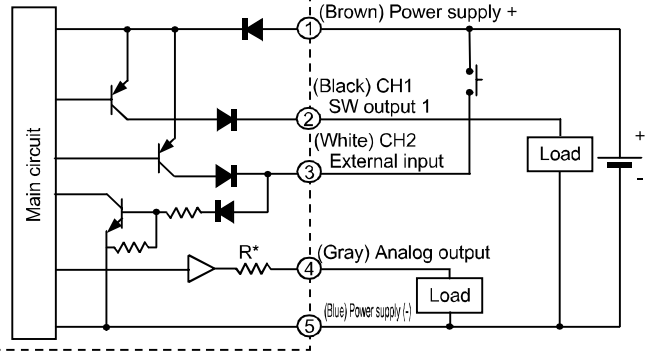

* Analog output: Voltage output R: approx. 1 kΩ
Current output R: approx. 100 Ω

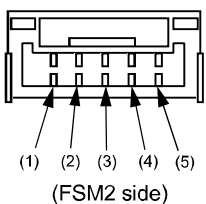

Terminal No.	Option cable color	Name
(1)	Brown	Power supply (+) (voltage output: 12 to 24 V, current output: 24 V)
(2)	Black	CH1 (Switch output 1: max. 50 mA)
(3)	White	CH2 (switch output 2: max. 50 mA, or external input)
(4)	Gray	Analog output Voltage output: 1 to 5 V load impedance 50 kΩ or more Current output: 4 to 20 mA load impedance 300 Ω or less
(5)	Blue	Power supply - (GND)

Example of internal circuit and load connection

● FSM2-A □ - □ (display separated)

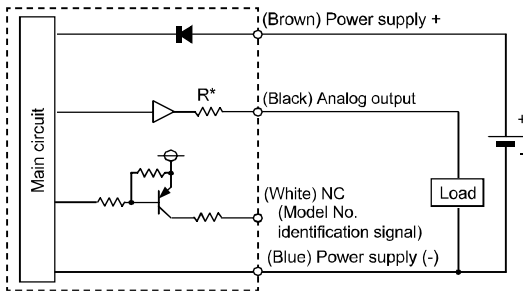

* Analog output: Voltage output R: approx. 1 kΩ
Current output R: approx. 100 Ω

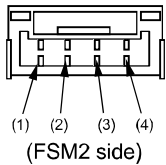

Terminal No.	Option cable color	Name
(1)	Brown	Power supply (+) (voltage output: 12 to 24 V, current output: 24 V)
(2)	Black	Analog output Voltage output: 1 to 5 V Load impedance 50 kΩ and over Current output: 4 to 20 mA Load impedance 300 Ω or less
(3)	White	NC (model identification signal; do not connect when using as single part)
(4)	Blue	Power supply - (GND)

● Connecting the separated display and FSM2 display separated

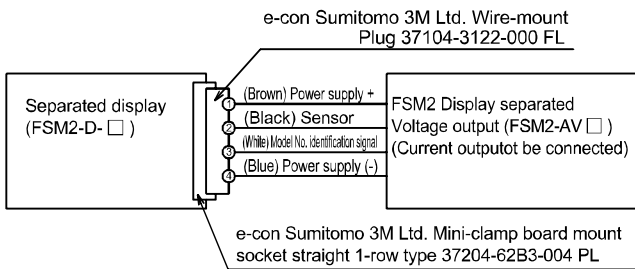

● Connecting the separated display and FSM display separated

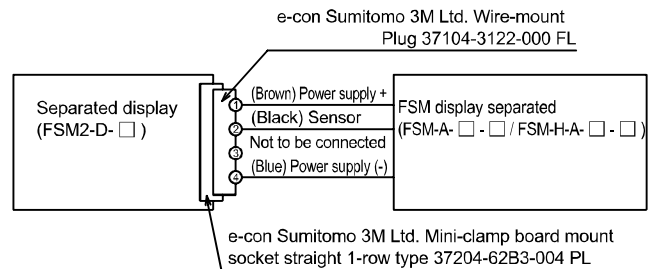

When connecting to the FSM-V Series or WFK Series, the cable size is different so a separate compatible sensor connection connector (e-con) will be required.

Analog output characteristics

Voltage output flow rate uni-direction

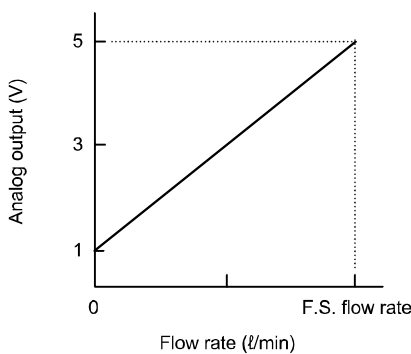

Current output flow rate uni-direction

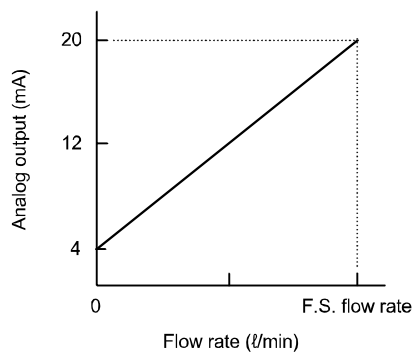

Voltage output flow rate bi-directional

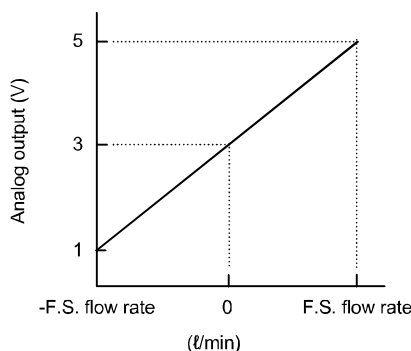

Current output flow rate bi-directional

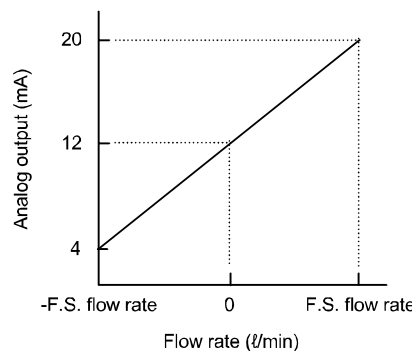

With the display integrated bi-directional, output can be changed to uni-direction output with the button settings. Refer to page 1278 for details.

- F.R.L
- F (Filtr)
- R (Reg)
- L (Lub)
- PresSW
- Shutoff
- SlowStart
- FmResistFR
- Oil-ProhR
- MedPresFR
- No Cu/ PTFE FRL
- Outdrs FR
- F.R.L (Related)
- CompFRL
- LgFRL
- PrecsR
- VacF/R
- Clean FR
- ElecPneuR
- AirBoost
- SpdContr
- Silncr
- CheckV/ other
- Jnt/tube
- AirUnt
- PresCompn
- Mech/ ElecPresSw
- ContactSW
- AirSens
- PresSW Cool
- AirFloSens/ Contr
- WaterPtSens
- TotAirSys (Total Air)
- TotAirSys (Gamma)
- RefrDry
- DesicDry
- HiPolymDry
- MainFiltr
- Dischrg etc
- Ending

F.R.L
F (Filtr)
R (Reg)
L (Lub)
PresSW
Shutoff
SlowStart
FmResistFR
Oil-ProhR
MedPresFR
No Cu/ PTFE FRL
Outdrs FR
F.R.L (Related)
CompFRL
LgFRL
PrecsR
VacF/R
Clean FR
ElecPneuR
AirBoost
SpdContr
Silncr
CheckV/ other
Jnt/tube
AirUnt
PrecsCompn
Mech/ ElecPresSw
ContactSW
AirSens
PresSW Cool
AirFloSens/ Contr
WaterRtSens
TotAirSys (Total Air)
TotAirSys (Gamma)
RefrDry
DesicDry
HiPolymDry
MainFiltr
Dischrg etc
Ending

Pressure loss characteristics (for air, nitrogen gas)

● FSM2-□005-□

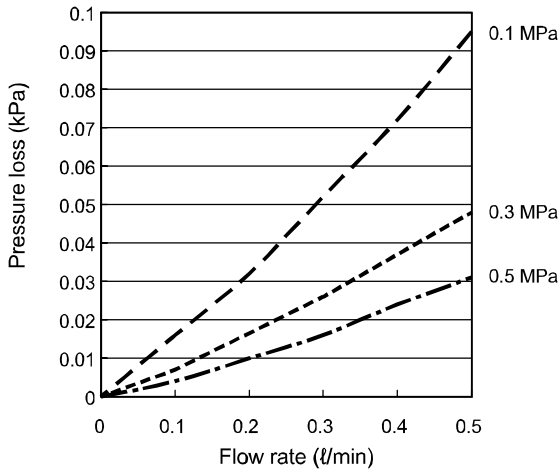

● FSM2-□010-□

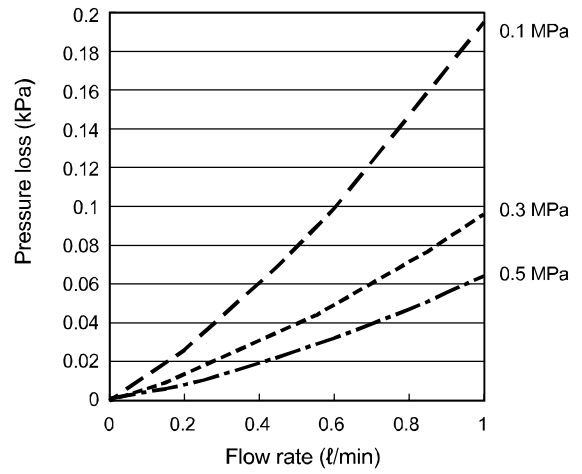

● FSM2-□020-□

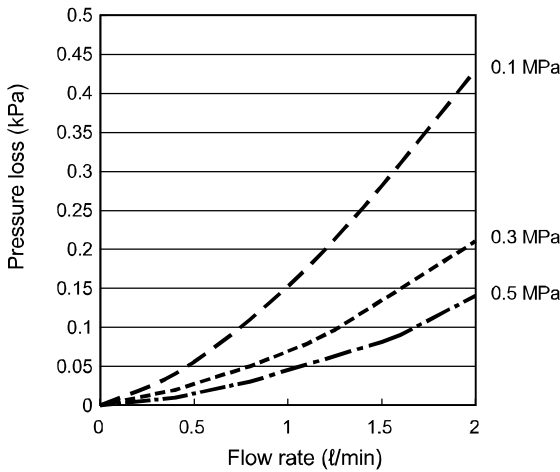

● FSM2-□050-□

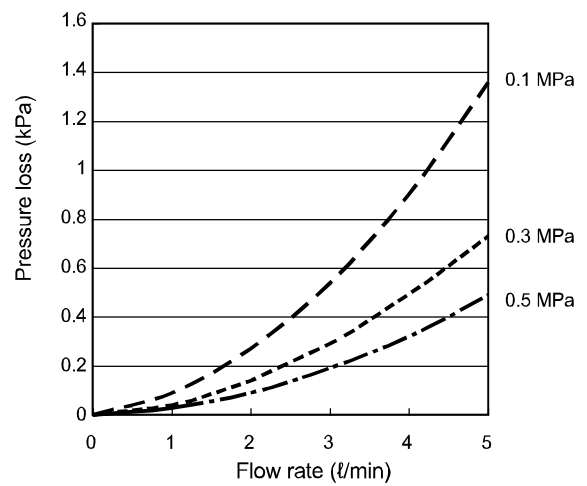

● FSM2-□100-□

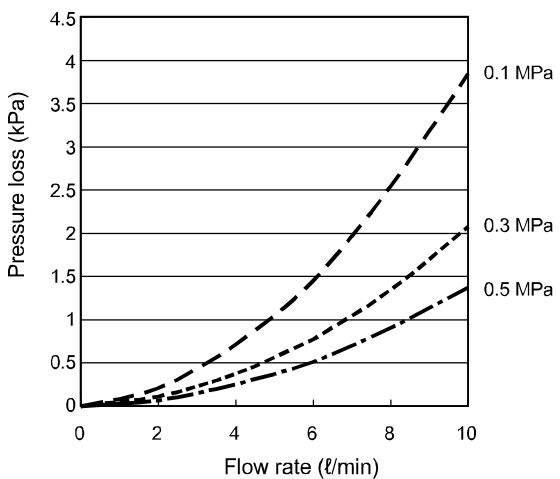

● FSM2-□200-□

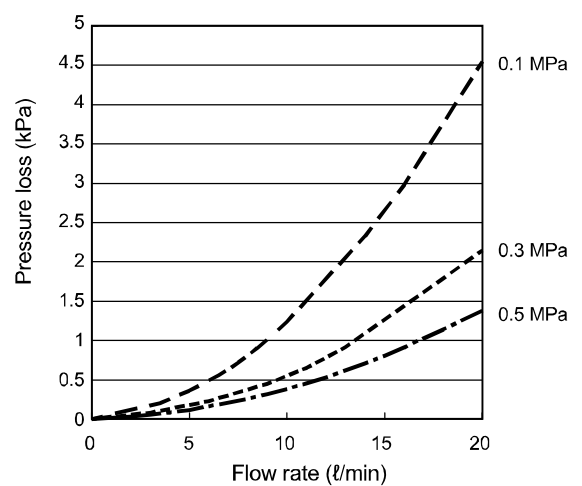

Pressure loss characteristics (for air, nitrogen gas)

● FSM2-□500-□

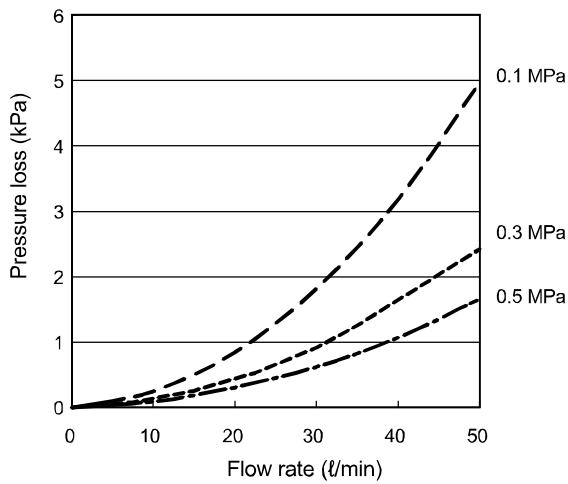

● FSM2-□101-□

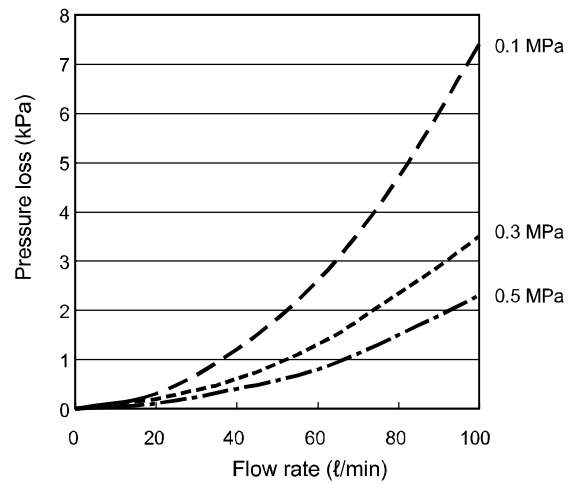

● FSM2-□201-□

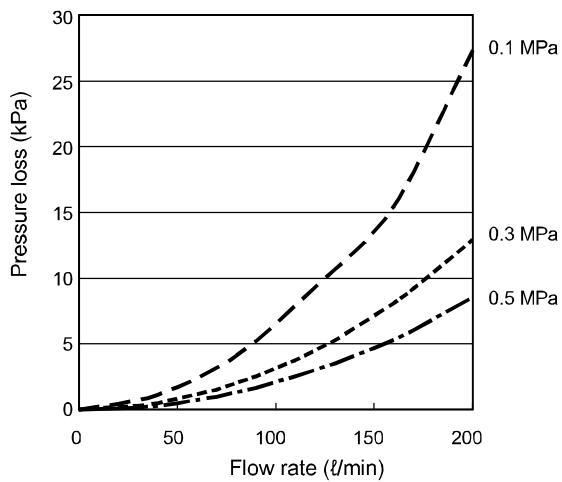

● FSM2-□501-□

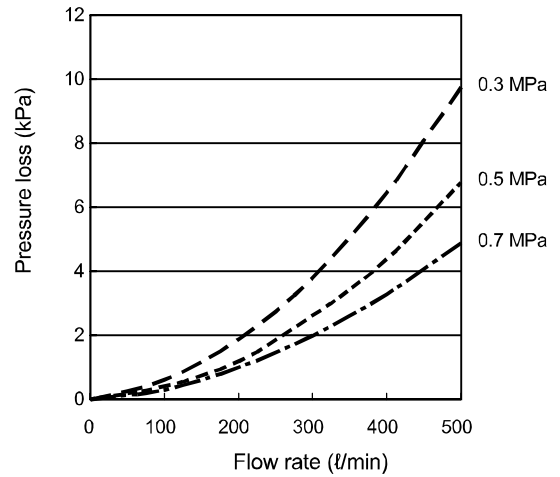

● FSM2-□102-□

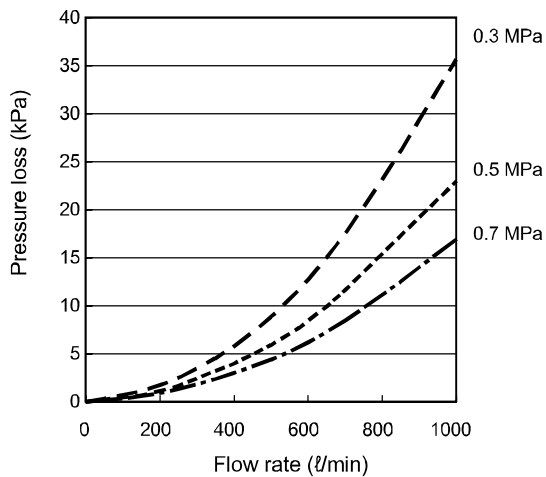

F.R.L
F (Filtr)
R (Reg)
L (Lub)
PresSW
Shutoff
SlowStart
FhiResistFR
Oil-ProhR
MedPresFR
No Cu/ PTFE FRL
Outdrs FR
F.R.L (Related)
CompFRL
LgFRL
PrecsR
VacF/R
Clean FR
ElecPneuR
AirBoost
SpdContr
Silncr
CheckV/ other
Jnt/tube
AirUnt
PresCompn
Mech/ ElecPresSw
ContactSW
AirSens
PresSW Cool
AirFloSens/ Contr
WaterRtSens
TotAirSys (Total Air)
TotAirSys (Gamma)
RefrDry
DesicDry
HiPolymDry
MainFiltr
Dischrg etc
Ending

F.R.L
F (Filtr)
R (Reg)
L (Lub)
PresSW
Shutoff
SlowStart
FmResistFR
Oil-ProhR
MedPresFR
No Cu/ PTFE FRL
Outdrs FR
F.R.L (Related)
CompFRL
LgFRL
PrecsR
VacF/R
Clean FR
ElecPneuR
AirBoost
SpdContr
Silncr
CheckV/ other
Jnt/tube
AirUnt
PrecsCompn
Mech/ ElecPresSw
ContactSW
AirSens
PresSW Cool
AirFloSens/ Contr
WaterRtSens
TotAirSys (Total Air)
TotAirSys (Gamma)
RefrDry
DesicDry
HiPolymDry
MainFiltr
Dischrg etc
Ending

Pressure loss characteristics (for argon)

● FSM2-□005-□AR

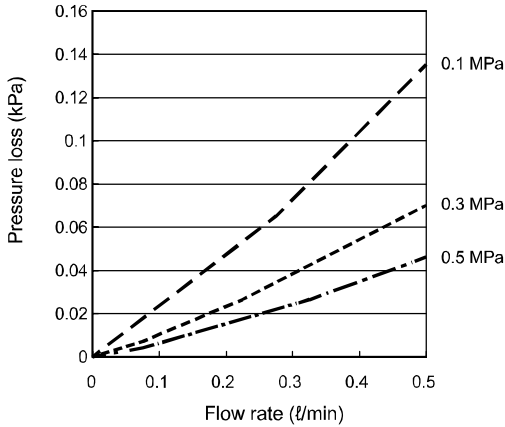

● FSM2-□010-□AR

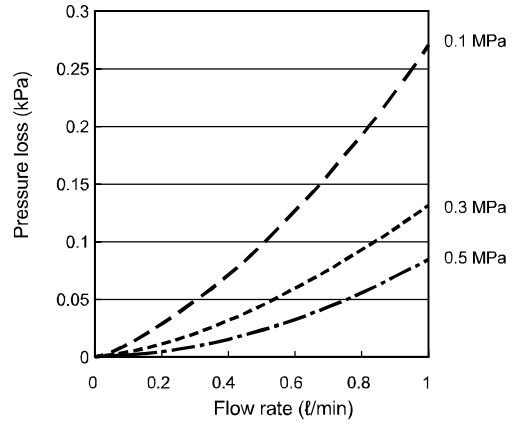

● FSM2-□020-□AR

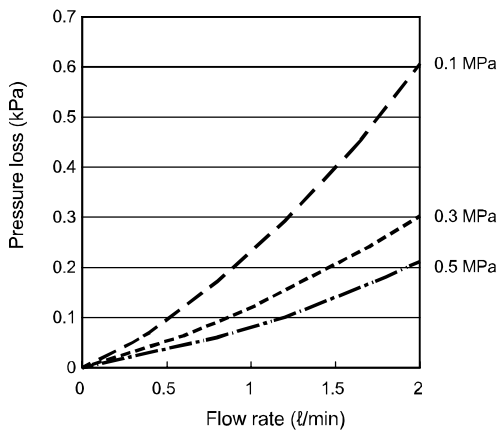

● FSM2-□050-□AR

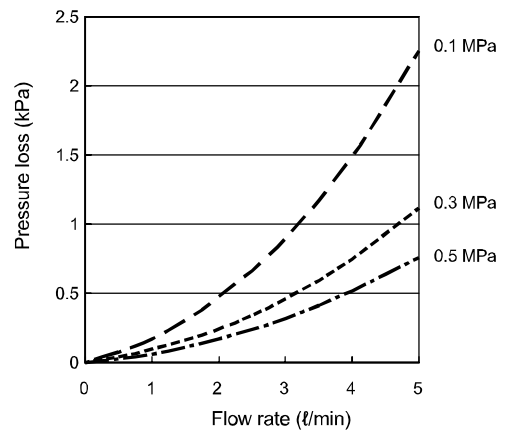

● FSM2-□100-□AR

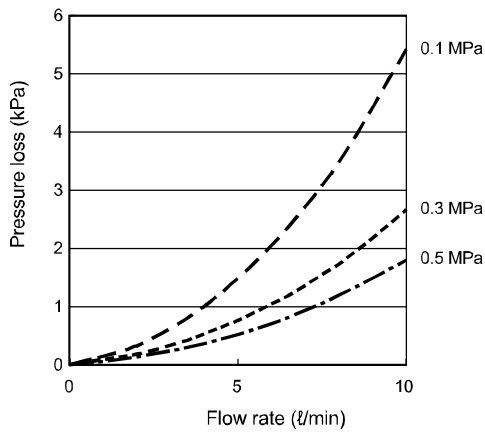

● FSM2-□200-□AR

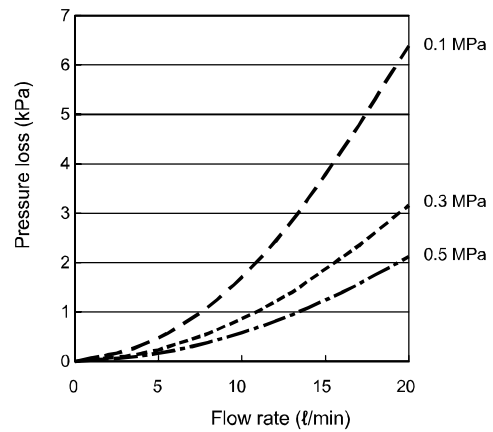

● FSM2-□500-□AR

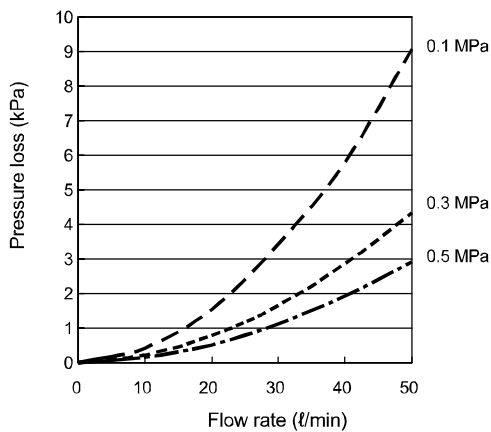

● FSM2-□101-□AR

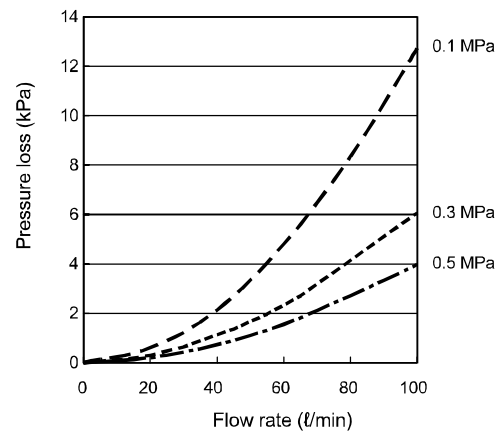

Pressure loss characteristics (for carbon dioxide)

● FSM2-□005-□C2

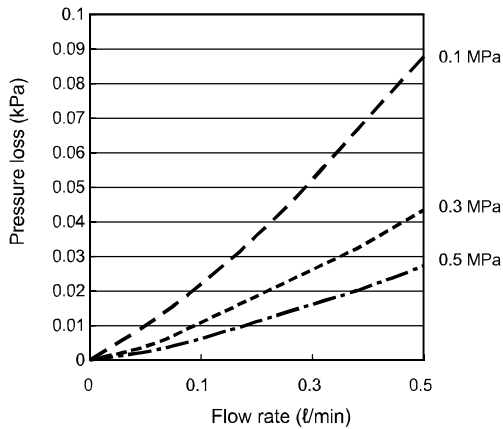

● FSM2-□010-□C2

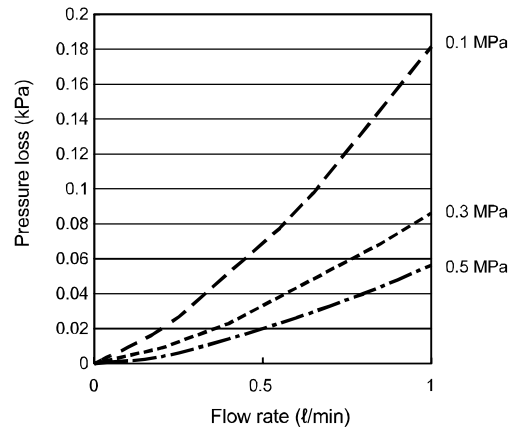

● FSM2-□020-□C2

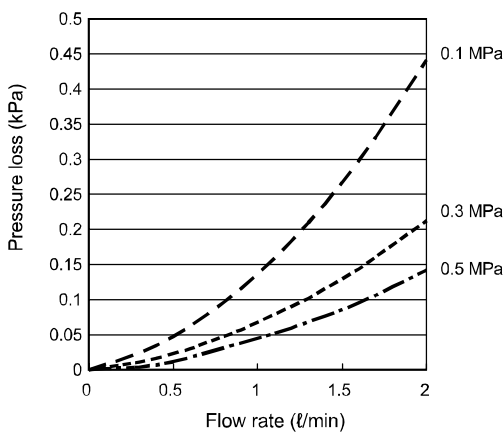

● FSM2-□050-□C2

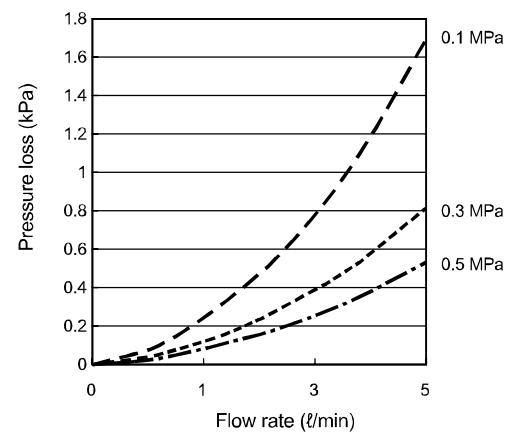

● FSM2-□100-□C2

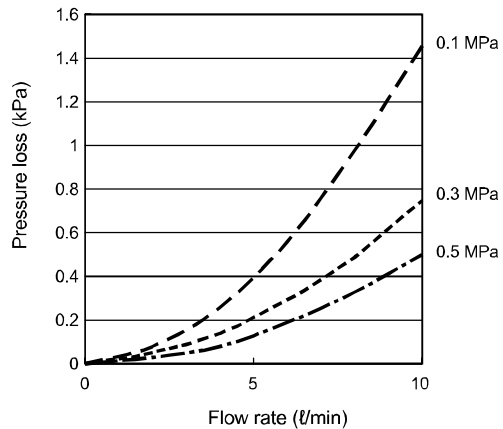

● FSM2-□200-□C2

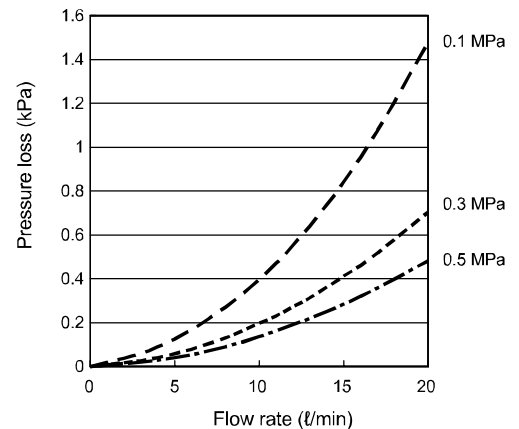

● FSM2-□500-□C2

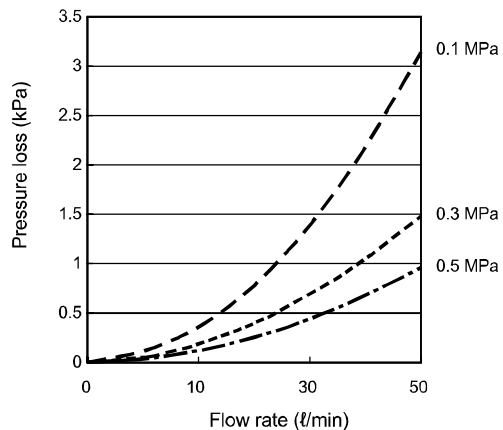

● FSM2-□101-□C2

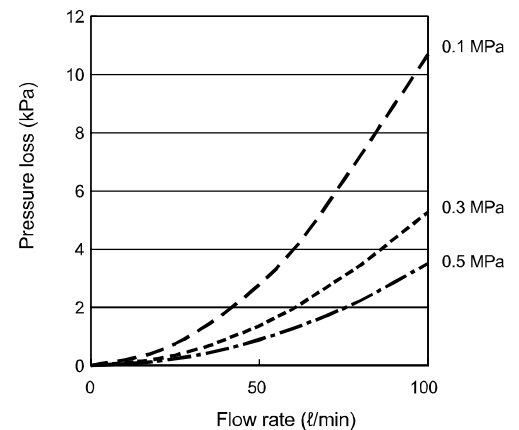

F.R.L
F (Filtr)
R (Reg)
L (Lub)
PresSW
Shutoff
SlowStart
FhiResistFR
Oil-ProhR
MedPresFR
No Cu/ PTFE FRL
Outdirs FR
F.R.L (Related)
CompFRL
LgFRL
PrecsR
VacF/R
Clean FR
ElecPneuR
AirBoost
SpdContr
Silncr
CheckV/ other
Jnt/tube
AirUnt
PresCompn
Mech/ ElecPresSw
ContactSW
AirSens
PresSW Cool
AirFloSens/ Contr
WaterRtSens
TotAirSys (Total Air)
TotAirSys (Gamma)
RefrDry
DesicDry
HiPolymDry
MainFiltr
Dischrg etc
Ending

F.R.L
F (Filtr)
R (Reg)
L (Lub)
PresSW
Shutoff
SlowStart
FlmResistFR
Oil-ProhR
MedPresFR
No Cu/ PTFE FRL
Outdrs FR
F.R.L (Related)
CompFRL
LgFRL
PrecsR
VacF/R
Clean FR
ElecPneuR
AirBoost
SpdContr
Silncr
CheckV/ other
Jnt/tube
AirUnt
PrecsCompn
Mech/ ElecPresSw
ContactSW
AirSens
PresSW Cool
AirFloSens/ Contr
WaterRtSens
TotAirSys (Total Air)
TotAirSys (Gamma)
RefrDry
DesicDry
HiPolymDry
MainFiltr
Dischrg etc
Ending

Needle valve flow characteristics (for air, nitrogen gas)

● FSM2- □ 005/010/020 (resin body)

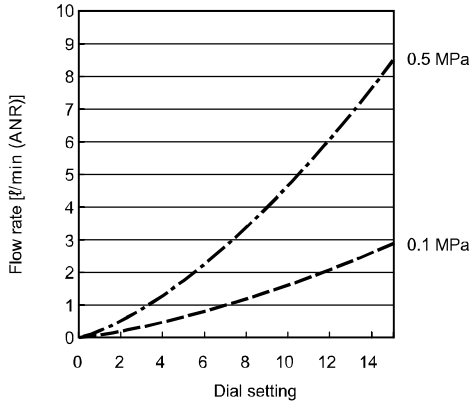

● FSM2- □ 050/100 (resin body)

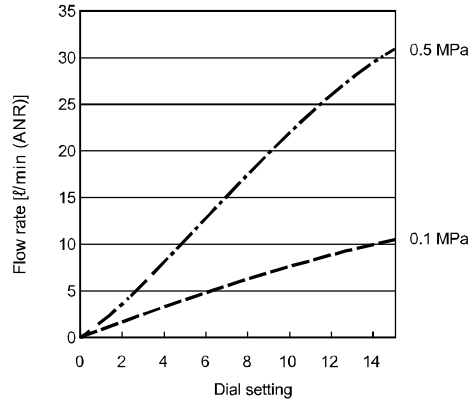

● FSM2- □ 200/500-H04/H06 (resin body)

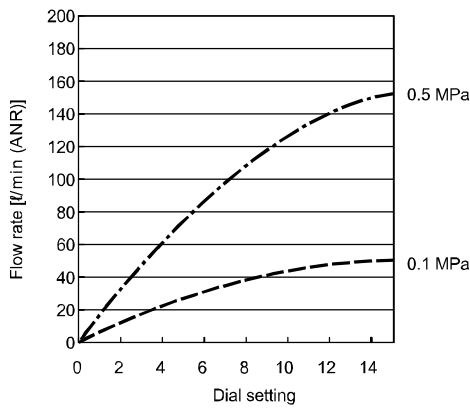

● FSM2- □ 500/101/201-H08/H10 (resin body)

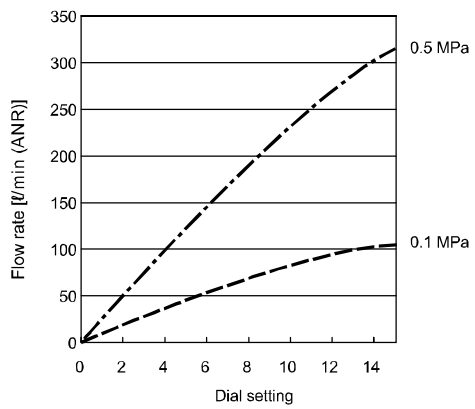

● FSM2- □ 005/010/020 (SUS body)

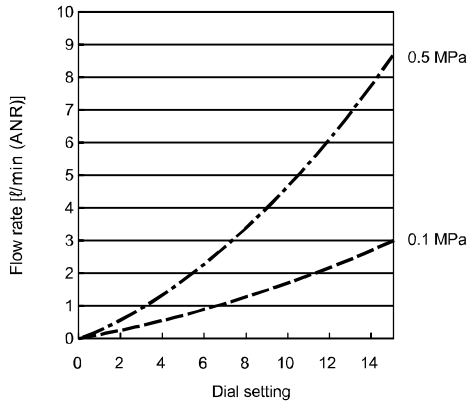

● FSM2- □ 050/100 (SUS body)

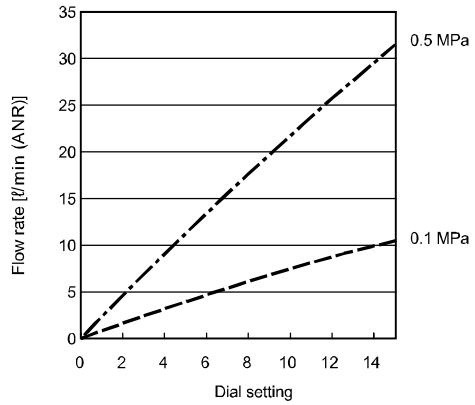

● FSM2- □ 200/500-S06 (SUS body)

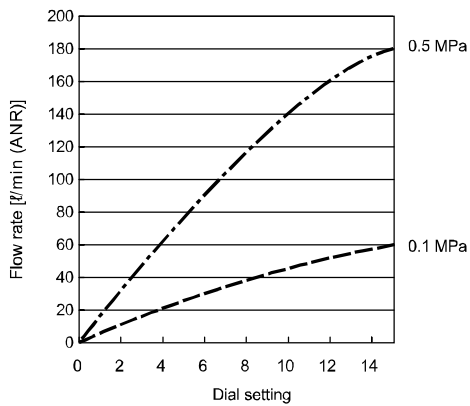

● FSM2- □ 500/101/201-S08 (SUS body)

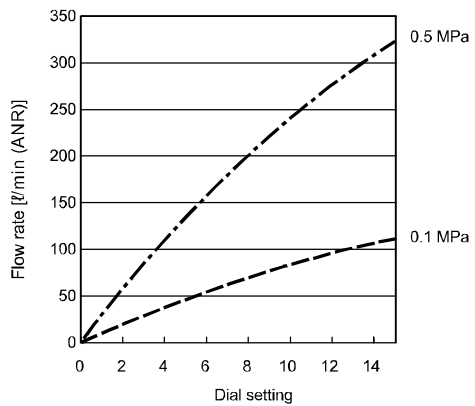

CAUTION: This characteristic value is a typical value and is not a guaranteed value.

Names and functions of display/operation section

● Display integrated

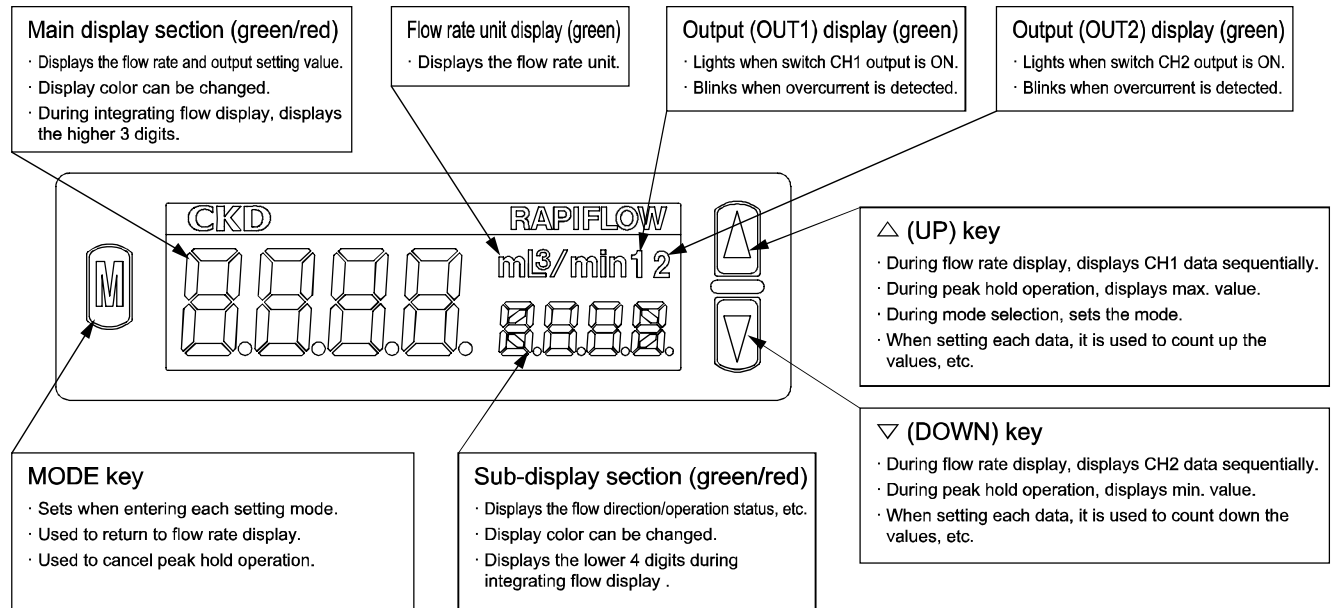

[Example] In the case of Model FSM2-NVR100- □

Display	Liquid crystal display
<p>Instantaneous flow rate display 10 l/min (ANR)</p> <p>In the case of 10L/min (ANR) When an excess flow of 11.0L/min runs in the opposite direction, "Lo" will be displayed. ("Lo" will be displayed at ≤-11.0L/min)</p> <p>When an excess flow of 11.0L/min runs forward, "Hi" will be displayed. ("Hi" will be displayed at ≥+11.0L/min)</p>	<p>* For bi-directional setting. (Note: In the case of a one-way type, "Lo" will be displayed at ≥1.0L/min in the opposite direction or ≤-1.0L/min)</p>
<p>How to display integrating flow For 99999.99l</p>	<p>* When the display range of "99999.99" is exceeded, the display returns to "0.00". (It is reset)</p>

* In the case of a one-way 10L/min type, "Hi" will be displayed at ≥11L/min in the forward direction or ≥+11L/min. "Lo" will be displayed at ≥1.0L/min in the opposite direction or ≤-1.0L/min.
In the case of a two-way 10L/min type, "Hi" will be displayed if ≥11.0L/min flows in the forward direction or ≥+11.0L/min. "Lo" if ≥11.0L/min flows in the opposite direction or ≤-11.0L/min.

- F.R.L
- F (Filtr)
- R (Reg)
- L (Lub)
- PresSW
- Shutoff
- SlowStart
- FlnResistFR
- Oil-ProhR
- MedPresFR
- No Cu/PTFE FRL
- Outdrs FR
- F.R.L (Related)
- CompFRL
- LgFRL
- PrecsR
- VacF/R
- Clean FR
- ElecPneuR
- AirBoost
- SpdContr
- Silncr
- CheckV/other
- Jnt/tube
- AirUnt
- PresCompn
- Mech/ElecPresSw
- ContactSW
- AirSens
- PresSW Cool
- AirFloSens/Contr
- WaterPtSens
- TotAirSys (Total Air)
- TotAirSys (Gamma)
- RefrDry
- DesicDry
- HiPolymDry
- MainFiltr
- Dischrg etc
- Ending

- F.R.L
- F (Filtr)
- R (Reg)
- L (Lub)
- PresSW
- Shutoff
- SlowStart
- FlmResistFR
- Oil-ProhrR
- MedPresFR
- No Cu/
PTFE FRL
- Outdrs FR
- F.R.L
(Related)
- CompFRL
- LgFRL
- PrecsR
- VacFR/R
- Clean FR
- ElecPneuR
- AirBoost
- SpdContr
- Silncr
- CheckV/
other
- Jnt/tube
- AirUnt
- PrecsCompn
- Mech/
ElecPresSw
- ContactSW
- AirSens
- PresSW
Cool
- AirFloSens/
Contr
- WaterRtSens
- TotAirSys
(Total Air)
- TotAirSys
(Gamma)
- RefrDry
- DesicDry
- HiPolymDry
- MainFiltr
- Dischrg
etc
- Ending

● Display separated

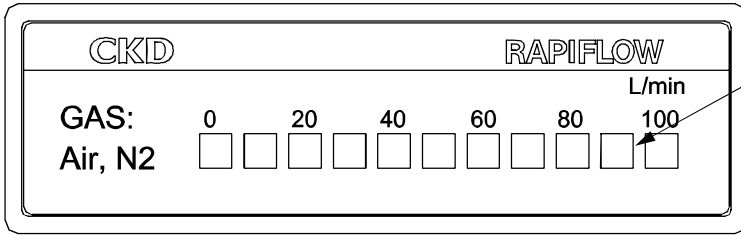

Flow bar display



- Lights according to flow rate.
- Blinks at overflow.

[Example] Display in the case of FSM2-A □ F101- □

Flow rate	Uni-direction	Bi-directional
0% F.S.		
+60% F.S. (Forward direction)		
+120% F.S. (Forward direction) Blinks at overflow * Blinks at +10% F.S. and over.		
-60% F.S. (Reverse direction)		
-120% F.S. (Reverse direction) Blinks at overflow * Blinks at -10% F.S. or less		

Error code

● Display integrated, needle valve integrated

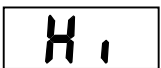
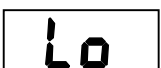
Error code	Cause	Countermeasures
	It was reset to not-corresponding flow rate when zero adjustment was performed.	Make sure to set the flow rate to zero, and then perform the zero adjustment.
	An error occurred during EEPROM reading or writing.	Turn power ON again. If the error is not resolved, contact your CKD branch or dealer.
	An error occurred during memory reading or writing.	Turn power ON again. If the error is not resolved, contact your CKD branch or dealer.
	The flow rate exceeds the flow rate display range.	Reduce the instantaneous flow rate value to within the flow rate range.
	Sensor failure	Turn power ON again. If the error is not resolved, contact your CKD branch or dealer.
	The flow rate is below the flow rate display range.	Increase the instantaneous flow rate value to within the flow rate range.
	Sensor failure	Turn power ON again. If the error is not resolved, contact your CKD branch or dealer.
Blinking of output display (Switch output is not output)	The switch output's over-current protection circuit has functioned.	Check whether load current exceeds the rating. Correctly connect, then turn power ON again.

● Display separated

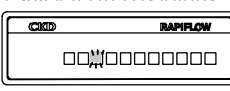
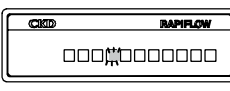
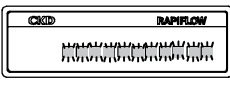
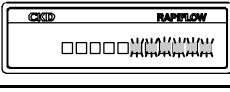
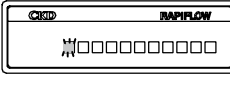
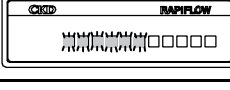
Error code	Cause	Countermeasures
The third from left blinks 	An error occurred during EEPROM reading or writing.	Turn power ON again. If the error is not resolved, contact your CKD branch or dealer.
The fourth from left blinks 	An error occurred during memory reading or writing.	Turn power ON again. If the error is not resolved, contact your CKD branch or dealer.
(Uni-direction) All blink 	The flow rate exceeds the flow rate display range.	Reduce the instantaneous flow rate value to within the flow rate range.
(Bi-direction) The right half blinks 	Sensor failure	Turn power ON again. If the error is not resolved, contact your CKD branch or dealer.
(Uni-direction) The leftmost blinks 	The flow rate is below the lower limit of the flow rate display range.	Increase the instantaneous flow rate value to within the flow rate range.
(Bi-direction) The left half blinks 	Sensor failure	Turn power ON again. If the error is not resolved, contact your CKD branch or dealer.

F.R.L
F (Filtr)
R (Reg)
L (Lub)
PresSW
Shutoff
SlowStart
FlnResistFR
Oil-ProhR
MedPresFR
No Cu/ PTFE FRL
Outdrs FR
F.R.L (Related)
CompFRL
LgFRL
PrescR
VacF/R
Clean FR
ElecPneuR
AirBoost
SpdContr
Silncr
CheckV/ other
Jnt/tube
AirUnt
PresCompn
Mech/ ElecPresSw
ContactSW
AirSens
PresSW Cool
AirFloSens/ Contr
WaterPtSens
TotAirSys (Total Air)
TotAirSys (Gamma)
RefrDry
DesicDry
HiPolymDry
MainFiltr
Dischrg etc
Ending

F.R.L Explanation of functions (display integrated)

The functions and various settings are made during the normal flow rate display and during the setting mode. The setting mode is divided into the standard setting mode and detailed setting mode according to the frequency of use.

● Normal operation

Descriptions	Explanation	Default setting
Instantaneous flow rate display	Displays the instantaneous flow rate.	-
Integrating flow display	The integrating flow can be displayed. The switch output function includes a function to turn the switch ON/OFF at a level higher than the recommended cumulative value, and an integrated pulse function to output the pulse at a set cumulative value. Reset when powered OFF. Can also be reset with button operations or external inputs.	Instantaneous flow rate display
Peak hold function	Max. and min. values for the flow rate within a set interval is displayed.	Peak hold OFF
Key lock function	The key operations can be locked to prevent inadvertent operations.	Key operation possible
Error display function	The error status is displayed when a fault or error occurs.	-

● Standard setting mode

Descriptions	Explanation	Default setting
Switch output function	This product has 2-point switch output, and uses seven operation patterns and a stop operation.	Switch is set to OFF for both CH1 and CH2
Forced output function	Use this function to forcibly turn the switch output ON and confirm the wiring connection or initial operation of the input device.	-
Zero adjustment	The zero point deviation is compensated. (Range: 0 ±10% F.S.)	Adjust value: 0

● Detailed setting mode

Descriptions	Explanation	Default setting
Select flow direction (only for bi-directional with display)	Setting the flow direction. Setting available for bi-directional, one-sided forward direction or one-sided reverse direction.	Bi-directional setting
Selection of CH2 operation	Select the CH2 setting. Select whether to use CH2 as a switch output, or to use as an external input (integrated value reset/auto reference).	Switch output
Auto reference function	When CH2 is selected as auto reference, the switch's output threshold can be imported with external inputs or button operations. The threshold can be changed automatically if the switch threshold value changes, such as when the workpiece is changed.	Auto reference function OFF
Response time setting	Set the response time. The response can be set in seven steps from 50 ms to approx. 1.5 s. Chattering and mis-operation caused by sudden flow rate changes or noise are prevented.	Response time: 50 ms
Display speed setting	The digital display refresh cycle can be set in three stages from 250 ms to 1 s. If the display flickers, it may be improved by setting a longer display refresh cycle.	Display speed: 250 ms
Sub-display setting	Set the sub-display section's display method. The display can be changed to flow direction, flow rate unit or gas type display.	Flow direction display
Display color setting	Set the display color. The color for a normal display and for switch output ON can be set.	Both main and sub At normal display: Green At switch ON: Red
Setting hysteresis	Set the switch setting value hysteresis. Use this if the flow rate pulsates or if the switch chatters near the threshold, etc.	Hysteresis: 1% F.S.
Setting flow rate unit	Select the display unit from the standard state or reference state. Standard condition (ANR): Converted into volumetric flow rate at 20°C, 1 barometric pressure Reference state (NOR): Converted into volumetric flow rate at 0°C, 1 barometric pressure (*1)	Flow rate unit: ANR
Setting ECO MODE	An ECO mode can be set. If the buttons are not operated for approx. one minute, the eco mode will activate and turn off the display's backlight. Current consumption can be reduced with this mode.	ECO MODE OFF
Reset setting	Returns the settings to the default settings. With the separated display, if the settings are reset and then the power is turned ON again with the FSM2 display separated (sensor section) connected, the flow rate range will be automatically recognized.	-
Model selection (separated display only)	Select the flow rate range, flow direction and gas type.	Not set (*2)

*1: The reference state display is a calculated (reference) value.

*2: The default setting is "Not set". If "Not set" is selected during use, the operation will start from the model selection mode after the power is turned ON. Always set the model before starting use.

The model is automatically recognized in the "Not set" state (default state) only when the FSM2 display separated (sensor) is connected.

Switch output function

The output function can be selected from seven types of switch operations according to the required application. The functions are compatible with both CH1 and CH2.

Name of operation pattern	Explanation	Operation waveform	LCD display
Window operation (1) (ON when inside range)	The switch turns ON when the level is within the designated flow rate range.		(Sub-display section)
Window operation (2) (ON when outside range)	The switch turns ON when the level is not within the designated flow rate range.		
Hysteresis operation (1) (ON at low flow rate side)	The hysteresis is randomly set, and the switch output turns OFF at the designated flow rate and higher.		
Hysteresis operation (2) (ON at high flow rate side)	The hysteresis is randomly set, and the switch output turns ON at the designated flow rate and higher. (The output is held even during the "Hi" display.)		
Cumulative value output (1) (ON at integrating flow or more)	Switch output turns ON at set cumulative value and higher.		
Cumulative value output (2) (OFF at integrating flow and over)	Switch output turns OFF at set cumulative value and higher.		
Integrated pulse output	The integrated pulse is output at the preset cumulative value. Refer to the "Integrating function" in the specifications for details on the preset integration value. (Pages 1238, 1239)		
Switch operation OFF	The switch operation is turned OFF.	-	

F.R.L
F (Filtr)
R (Reg)
L (Lub)
PresSW
Shutoff
SlowStart
FmResistFR
Oil-ProhR
MedPresFR
No Cu/PTFE FRL
Outdrs FR
F.R.L (Related)
CompFRL
LgFRL
PrecsR
VacF/R
Clean FR
ElecPneuR
AirBoost
SpdContr
Silncr
CheckV/other
Jnt/tube
AirUnt
PresCompn
Mech/ElecPresSw
ContactSW
AirSens
PresSW Cool
AirFloSens/Contr
WaterPtSens
TotAirSys (Total Air)
TotAirSys (Gamma)
RefrDry
DesicDry
HiPolymDry
MainFiltr
Dischrg etc
Ending





Automatic reference function

When CH2 is selected as auto reference, the switch's output threshold can be imported with external inputs or button operations. The threshold can be changed automatically if the switch threshold value changes, such as when the workpiece is changed. The flow rate value at the point where the external input is turned ON is read for the input value. The CH2 switch settings are invalid during auto referencing.

Inputs No.	Name of operation pattern	Explanation	Operation waveform	LCD display
1 point	ON at input value or higher	ON when higher than imported value. (Threshold: input value)		(Main display section)
	OFF at input value or higher	OFF when higher than imported value. (Threshold: input value)		(Main display section)
2 points	ON when higher than middle value of two points	ON when higher than middle value of two imported points. (Threshold: (input (1) + input (2))/2)		(Main display section)
	OFF when higher than middle value of two points	OFF when higher than middle value of two imported points. (Threshold: (input (1) + input (2))/2)		(Main display section)
	ON between 2 points	ON when between two imported points. (Threshold (1): input value (1)) (Threshold (2): input value (2))		(Main display section)
	OFF between 2 points	OFF when between two imported points. (Threshold (1): input value (1)) (Threshold (2): input value (2))		(Main display section)

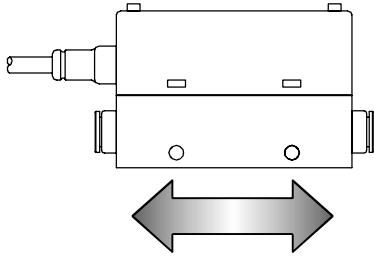
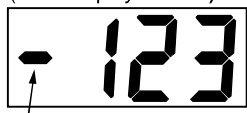
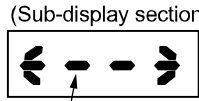
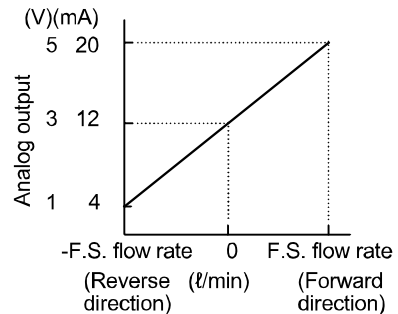
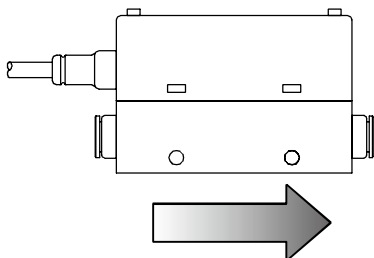
Selecting the flow direction (display integrated, bi-directional only)

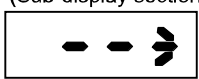
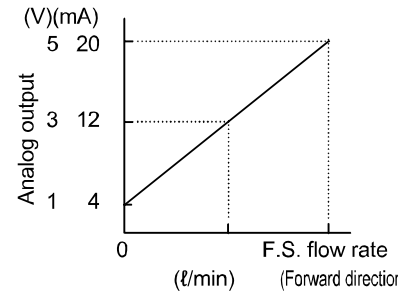
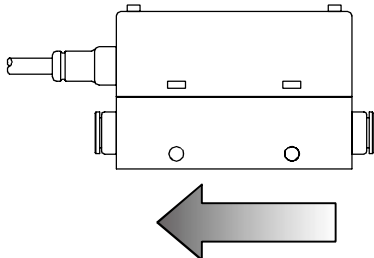
The flow rate for the display integrated, bi-directional can be set with buttons. The value after switching is a reference value.

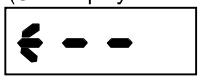
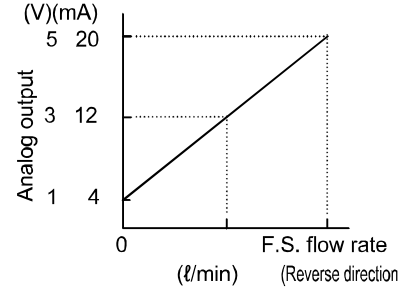
Flow direction	LCD display	Analog output characteristics
<p>[Bi-directional]</p> 	<p>(Main display section)</p>  <p>A minus mark (-) displays during reverse-direction flows</p> <p>(Sub-display section)</p>  <p>The arrow-mark display changes in accordance with the flow direction</p>	
<p>[Uni-direction (forward direction)]</p> 	<p>(Main display section)</p>  <p>(Sub-display section)</p> 	
<p>[Uni-direction (reverse direction)]</p> 	<p>(Main display section)</p>  <p>(Sub-display section)</p> 	

- F.R.L
- F (Filtr)
- R (Reg)
- L (Lub)
- PresSW
- Shutoff
- SlowStart
- FlnResistFR
- Oil-ProhR
- MedPresFR
- No Cu/PTFE FRL
- Outdrs FR
- F.R.L (Related)
- CompFRL
- LgFRL
- PrecsR
- VacF/R
- Clean FR
- ElecPneuR
- AirBoost
- SpdContr
- Silncr
- CheckV/other
- Jnt/tube
- AirUnt
- PresCompn
- Mech/ElecPresSw
- ContactSW
- AirSens
- PresSW Cool
- AirFloSens/Contr
- WaterPtSens
- TotAirSys (Total Air)
- TotAirSys (Gamma)
- RefrDry
- DesicDry
- HiPolymDry
- MainFiltr
- Dischrg etc
- Ending

- F.R.L
- F (Filtr)
- R (Reg)
- L (Lub)
- PresSW
- Shutoff
- SlowStart
- FlmResistFR
- Oil-ProhR
- MedPresFR
- No Cu/ PTFE FRL
- Outdrs FR
- F.R.L (Related)
- CompFRL
- LgFRL
- PrecsR
- VacF/R
- Clean FR
- ElecPneuR
- AirBoost
- SpdContr
- Silncr**
- CheckV/ other
- Jnt/tube
- AirUnt
- PrecsCompn
- Mech/ ElecPresSw
- ContactSW
- AirSens
- PresSW Cool
- AirFloSens/ Contr**
- WaterRtSens**
- TotAirSys (Total Air)
- TotAirSys (Gamma)
- RefrDry
- DesicDry
- HiPolymDry
- MainFiltr
- Dischrg etc
- Ending

Measurement principle of FSM2 Series

The FSM2 Series incorporates a platinum sensor chip (3 mm x 3.5 mm) machined with silicon micro-machining. The sensor is thermally insulated from the silicon substrate. The heating capacity is extremely low, enabling high sensitivity with a high-speed response.

At the sensor, two temperature sensors are arranged with a heater in between. Platinum, which has a resistance that changes based on temperature, is used for the temperature sensor. When the heater is turned ON and heating occurs, the temperature distribution is symmetrical to the center of the heater if there is no flow. When flow is received, the symmetrical property of the temperature distribution is lost, temperature upstream from the heater drops, and temperature downstream rises. This temperature difference appears as the difference in temperature sensor resistance, and varies with the flow rate. When the flow is reversed, the temperature difference (difference in resistance) will be inverted. By using this method, the bi-directional flow rate can be detected. This method is suitable for detecting a relatively small flow rate.

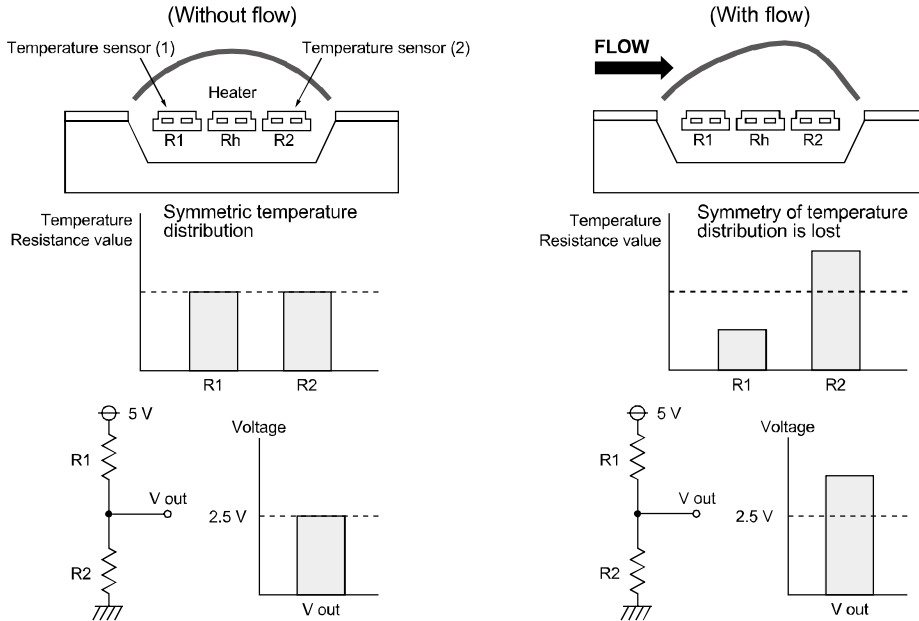

MEMO

F.R.L
F (Filtr)
R (Reg)
L (Lub)
PresSW
Shutoff
SlowStart
FmResistFR
Oil-ProhR
MedPresFR
No Cu/ PTFE FRL
Outdrs FR
F.R.L (Related)
CompFRL
LgFRL
PrecsR
VacF/R
Clean FR
ElecPneuR
AirBoost
SpdContr
Silncr
CheckV/ other
Jnt/tube
AirUnt
PresCompn
Mech/ ElecPresSw
ContactSW
AirSens
PresSW Cool
AirFloSens/ Contr
WaterPtSens
TotAirSys (Total Air)
TotAirSys (Gamma)
RefrDry
DesicDry
HiPolymDry
MainFiltr
Dischrg etc
Ending



Safety precautions

Pneumatic components: Warning and Cautions

Be sure to read this section before use.

Refer to Intro Page 63 for precautions for general pneumatic components.

Design/selection

Working fluids

⚠ DANGER

- Never use with a flammable fluid.

⚠ WARNING

- This product cannot be used as a billing meter. Do not use this product for commercial transactions as it is not compliant with the Measurement Act. Intended applications include industrial sensors.
- Do not use fluids other than the applicable fluids, because accuracy cannot be guaranteed.
- When using compressed air, use clean air that complies with JIS B 8392-1: 2012 Class [1: 1: 1 to 1: 6: 2]. As compressed air from the compressor contains drainage (water, oil oxides, foreign matter, etc.), install a filter, air dryer, and oil mist filter (micro alescer) on the primary side (upstream side) of the sensor. The sensor's mesh rectifies flow in the pipe. It does not filter out foreign matter, so provide a filter.

[Recommended circuit]

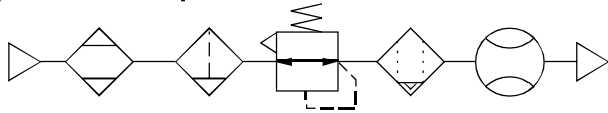

Source pressure Air dryer Filter Regulator Oil mist filter (micro alescer) Flow rate sensor (FSM Series)

- When using a valve on the primary side of the sensor, use only valves with oil-prohibited specifications. This sensor could malfunction or fail if exposed to splattering grease, oil, etc. As friction powder may be generated depending on the valve, mount a filter to prevent the powder from entering the sensor.
- When using with liquefied gases such as carbon dioxide, always vaporize the gas. Failure may result if liquefied gas enters the product.
- Use dry gas which does not contain corrosive elements such as chlorine, sulfur or acids, and which is clean and does not contain dust or oil mist.
- Depending on the fluid, retaining the fluid for a long time could adversely affect the performance. Do not seal the fluid in the pipe for long periods of time.

Working environment

⚠ DANGER

- Explosion-proof environments
Never use this product in an explosive gas atmosphere. The structure is not explosion-proof, and explosions or fires could occur.

⚠ WARNING

- Corrosive environments
Do not use this product in an atmosphere containing corrosive gases such as sulfur dioxide.
- Ambient / fluid temperatures
Use ambient / fluid temperatures from 0 to 50°C within the specified range. Even if the temperature is within the specified range, do not use this product if the ambient / fluid temperatures could suddenly change and cause dew to condense.
- Working pressure/flow rate range
Applications exceeding the max. working pressure and specified flow rate range may result in faults. Use this product only within the specified range.
- Drip-proof environments
The degree of protection of this product is equivalent to IP40. Do not install this product where water, salt, dust, or swarf is present or in a pressurized or depressurized environment. The product cannot be used with large temperature variations or high temperature/humidity since condensation may occur inside the body.

Flow rate unit

⚠ CAUTION

- This product's flow rate is measured at a mass flow rate unaffected by temperature or pressure. The unit is $l/min.$, but this is the display when the mass flow rate is converted to volumetric flow rate at 20°C 1 barometric pressure (101 kPa) relative humidity 65%.

Proof pressure

⚠ CAUTION

- Proof pressure differs depending on the series. Take note at selection.

Overflow

⚠ CAUTION

- With each series, the sensor can handle an overflow double the measured range. If dynamic pressure is applied near the maximum working pressure (when a pressure difference exceeding the max. working pressure is applied between primary and secondary sides), the sensor may operate abnormally. If dynamic pressure is applied, such as when a workpiece is filled for leakage inspection, provide a bypass circuit or restrictor so that dynamic pressure is not applied to the sensor.

F.R.L
F (Filtr)
R (Reg)
L (Lub)
PresSW
Shutoff
SlowStart
FlmResistFR
Oil-Prohr
MedPresFR
No Cu/ PTFE FRL
Outdrs FR
F.R.L (Related)
CompFRL
LgFRL
PrecsR
VacF/R
Clean FR
ElecPneuR
AirBoost
SpdContr
Silncr
CheckV/ other
Jnt/tube
AirUnt
PrecsCompn
Mech/ ElecPresSw
ContactSW
AirSens
PresSW Cool
AirFloSens/ Contr
WaterRtSens
TotAirSys (Total Air)
TotAirSys (Gamma)
RefrDry
DesicDry
HiPolymDry
MainFiltr
Dischrg etc
Ending

Use for suction confirmation, etc.

CAUTION

- When this product is used to confirm suction, etc., select the flow rate range based on the operating vacuum pressure and suction nozzle. Refer to "Flow rate sensor selection method" on page 1316 for details.
- When this product is used to confirm suction, etc., provide an air filter upstream from suction to prevent the entry of foreign matter.
- When this product is used to confirm suction, etc., consider the atmospheric dew point and the product's ambient temperature, and use the product under conditions in which dew does not condense in pipes.
- When this product is used to confirm suction, etc., response time may be delayed by the piping volume between the suction nozzle and this product. In this case, take countermeasures to reduce piping capacity.
- When this product is used for vacuum applications such as air suction, do not bend the tube near the push-in fitting. If stress is applied to the tube near the push-in fitting, insert an insert ring into the tube, and connect the tube to the push-in fitting.

Use for leakage inspections

- The working pressure range of this product is -0.09 to 1.00 MPa. If energized in a vacuum state of -0.09 MPa or less, the sensor's heat dissipation performance will suffer, leading to degradation of the sensor.
- When the suction confirmation sensor is switched from a pressure sensor (switch) to a flow rate sensor (switch), sensor output (switch output) logic will be reversed. (Refer to the figure below). Note that the PLC sequence program must be changed or revised. If source pressure or vacuum source is not supplied when device power is turned ON, "flow rate 0" = "sensor output (switch output) ON" status is set at the flow rate sensor (switch). Check that this is not a problem with the PLC sequence program, etc.

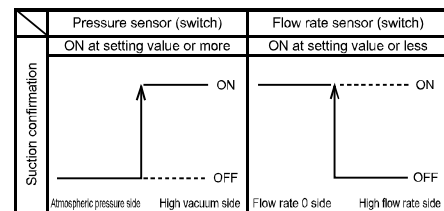

Mounting, installation and adjustment

Piping

CAUTION

- Always attach the pipes before starting wiring.
- Align the fluid flow direction to the direction indicated on the body when connecting the pipes.
- When installing the sensor on piping, refer to the torque below so that excessive screw-in torque or load torque is not applied to the connection port.

[Reference value]

Port thread	Tightening torque N·m
M5	1.0 to 1.5
Rc1/8(G1/8)	3 to 5
Rc1/4	6 to 8
Rc1/2	16 to 18

- Before installing piping, clean out the pipes using air blower to remove all foreign matter and cutting chips from the pipes. The rectifier or sensor chip could be damaged if a large amount of foreign matter, cutting chips, etc., enters.
- Attach a wrench to metal sections when tightening pipes so that force is not applied to the resin section.

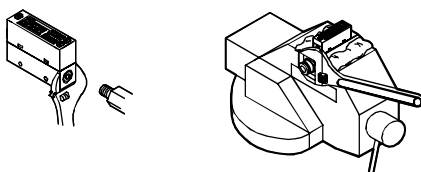

- Check that the sealant tape or sealant material does not get inside during piping. * When using for clean-room specifications, make sure that the sealant material matches the system being used.

When winding fluoro resin sealing tape around threads, wind sealing tape once or twice, leaving two to three threads open at the end of the screw. Press tape with a nail tip to stick it onto threads. When using liquid sealant, leave one to two threads open from the end, and avoid applying too much. Check that the sealant does not get on device threads.

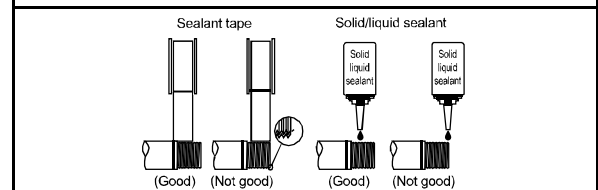

- Be sure to connect a fitting even when using the metal body with the OUT side opened. The port filter could come Off.
- When using a push-in fitting, accurately insert tube and confirm that it cannot be pulled out. Cut the tube at a right angle with a dedicated cutter before use.
- Make sure that the leakage detection solution does not enter the case when inspecting the pipe for leaks.
- Do not install the regulator/solenoid valve, etc., immediately before this product. Generated drift may cause errors. Provide a straight piping section if required.
- Although the mounting is "unrestricted in vertical/horizontal direction", the flow rate may vary depending on difference in the mounting orientation or piping conditions.

Mounting

CAUTION

- The display integrated flow rate meter uses a liquid crystal display. This may be difficult to read depending on the angle.
- Do not install multiple product bodies in close contact. The generation of heat on each part could cause the product's temperature to rise, hastening changes in characteristics or deterioration of the resin material. When using the products in a row, set intervals of distance of 10 mm and over.

F.R.L
F (Filtr)
R (Reg)
L (Lub)
PresSW
Shutoff
SlowStart
FmResistFR
Oil-ProhR
MedPresFR
No Cu/ PTFE FRL
Outdrs FR
F.R.L (Related)
CompFRL
LgFRL
PrescR
VacF/R
Clean FR
ElecPneur
AirBoost
SpdContr
Silncr
CheckV/ other
Jnt/tube
AirUnt
PresCompn
Mech/ ElecPresSw
ContactSW
AirSens
PresSW Cool
AirFloSens/ Contr
WaterPtSens
TotAirSys (Total Air)
TotAirSys (Gamma)
RefrDry
DesicDry
HiPolymDry
MainFiltr
Dischrg etc
Ending

Mounting, installation and adjustment

F.R.L
F (Filtr)
R (Reg)
L (Lub)
PresSW
Shutoff
SlowStart
AmResistFR
Oil-ProhR
MedPresFR
No Cu/ PTFE FRL
Outdrs FR
F.R.L (Related)
CompFRL
LgFRL
PrecsR
VacF/R
Clean FR
ElecPneuR
AirBoost
SpdContr
Silncr
CheckV/ other
Jnt/tube
AirUnt
PrecsCompn
Mech/ ElecPresSw
ContactSW
AirSens
PresSW Cool
AirFloSens/ Contr
WaterRtSens
TotAirSys (Total Air)
TotAirSys (Gamma)
RefrDry
DesicDry
HiPolymDry
MainFiltr
Dischrg etc
Ending

■ This product can be installed in any direction; top, bottom, left, or right.

Lateral mounting (use of through hole)

Vertical mounting (use of female thread on bottom surface)

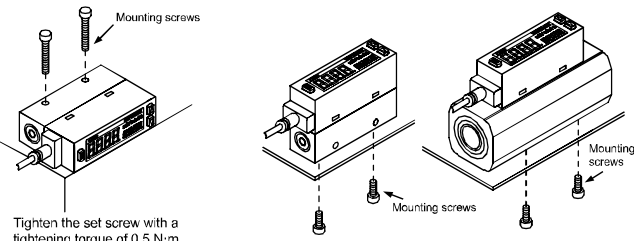

Tighten the set screw with a tightening torque of 0.5 N·m.

Bracket mounting (use of dedicated bracket)

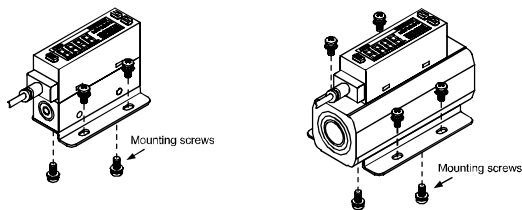

Port size: Push-in fitting $\phi 4$, $\phi 6$, $\phi 8$, $\phi 10$
Rc 1/8, Rc 1/4, M5

Port size: Rc 1/2
Single bracket model No.: FSM2-LB2

Single bracket model No.: FSM2-LB1

Tighten the set screw with a tightening torque of 0.5 N·m.

Panel mounting

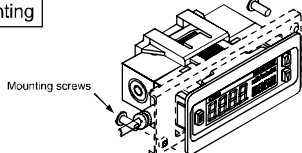

Tighten the set screw with a tightening torque of 0.06 N·m.

Complete the piping before assembly.

If the pipes are connected after assembly, excessive stress will be applied and may damage the product.

When using the panel mounting method, make sure that vibration is not applied to the product. When using on a stainless steel body, the vibration will be amplified and could damage the product.

Wiring

⚠ DANGER

■ Use power supply voltage and output within the specified voltage. If voltage exceeding the specified voltage is applied, the sensor could malfunction or be damaged, or electrical shock or fire could occur. Do not use any load that exceeds the rated output. Otherwise, output damage or fire may result.

⚠ WARNING

■ Check line color when wiring. As incorrect wiring could result in sensor damage and malfunctions, check wire color against the instruction manual before wiring.

■ Ensure that wires are properly insulated. Check that wires do not come into contact with other circuits, that no ground faults occur, and that the insulator between terminals is not defective. Overcurrent could flow in and damage the sensor.

■ Use a stabilized DC power supply within the specified rating that has been insulated from the AC power supply. A non-insulated power supply could result in electrical shock. If power is not stabilized, the peak value could be exceeded. This could damage the product or impair accuracy.

■ Always attach the connector bar after connecting the connector.

■ Check that stress (7 N and over) is not directly applied to cable leadouts or connectors.

■ Stop the control device and equipment and turn power OFF before wiring. Starting operation suddenly could cause unpredictable and dangerous operation. Conduct an energized test with controls and machine devices stopped, and set target switch data. Be sure to discharge any accumulated electrostatic charge among personnel, tools, or equipment before and during work. Connect and wire bending resistant material, such as robot wire material for movable sections.

■ Do not use at levels exceeding the power supply voltage range. If voltage exceeding this range or AC power is applied, the controller could rupture or burn.

■ Install the product and wiring away from sources of noise, such as power distribution wires. Provide separate countermeasures for surge applied to the power cable. The display or output could fluctuate.

■ Do not short-circuit the load. Failure to observe this could result in rupture or burning.

■ The power supply for the metal body (stainless steel body, aluminum body) is a DC stabilized power supply completely isolated from the AC primary side. Connect either the + side or - side of the power to the F.G. Between the metal body internal power circuit and metal body, a varistor (limit voltage approx. 40 V) is connected to prevent dielectric breakdown of the sensor. Do not conduct a withstand voltage test or insulation resistance test between the internal power circuit and metal body. Disconnect wiring first if this testing is required. An excessive potential difference between power and metal body will burn internal parts. After installing, connecting and wiring the metal body, electrical welding of the equipment/frame or short-circuit accidents, etc., could cause welding current, excessive high voltage caused by welding, or surge voltage, etc., to run through the wiring, ground wire, or fluid path connected between such devices, damaging wires or devices. Conduct any work such as electrical welding after removing this device and disconnecting all electric wires connected to the F.G.

■ Connecting load

The output impedance of the analog output section is approx. 1 k Ω . If the impedance of the connecting load is small, output error increases. Check error with the impedance of the connecting load before using. (The analog output current output is excluded.)

Example of calculation

$$\begin{aligned} & \left(\begin{array}{l} \text{FSM2-}\square\text{V output impedance: } R_o = 1 \text{ k}\Omega \\ \text{Load internal impedance} \quad : R_x = 1 \text{ M}\Omega \end{array} \right. \\ & \text{Output value} = \left(1 - \frac{R_o}{R_o + R_x} \right) \times 100\% \\ & = \left(1 - \frac{1 \text{ k}\Omega}{1 \text{ k}\Omega + 1 \text{ M}\Omega} \right) \times 100\% \Rightarrow \text{error approx. } 0.1\% \end{aligned}$$

During adjustment

⚠ CAUTION

■ If switches are operated when fluid is pulsating or flow rate is otherwise unstable, operation may be unstable. In this case, provide sufficient margin between the two setting values and avoid setting switches in an unstable area. Confirm that switch operation is stable before use.

Use/maintenance

⚠ WARNING

- Output accuracy is affected by temperature characteristics and heat generated when energized. Provide a standby time (5 minutes or more) after turning the power ON for use.
- Immediately after power is turned ON, this product does not start flow rate detection switch operation for approx. 4 seconds to complete self-diagnosis. Provide a control circuit/program that ignores signals for at least four seconds after power is turned ON.

⚠ CAUTION

- This product uses a micro-sensor chip, and must be installed where it will not be subject to dropping, impact or vibration. Handle this product as a precision component during installation and transportation.
- If a problem occurs during operation, immediately turn the power OFF, stop use, and contact your dealer.
- Keep this product's flow rate within the rated flow range.
- Use this product within the working pressure.
- When changing the output set value, turn OFF the equipment first in order to prevent unexpected operation in the control system equipment.
- Do not disassemble or modify, as this may cause malfunction.
- The case is made of resin. Do not use solvent, alcohol or detergent in cleaning, or resin could absorb it. There is a risk of affecting the resin. Wipe off dirt with a rag soaked in a diluted neutral detergent solution and wrung out well.
- Pay attention to the reverse current caused by disconnected wires/wiring resistance. If other devices, including a flow rate sensor, are connected to the same power supply as the flow rate sensor, and the switch output wire and power cable negative (-) side are short-circuited to check the operation of the control panel input unit, or if the power cable negative (-) side is disconnected, reverse current could flow to the flow rate sensor's switch output circuit and cause damage.

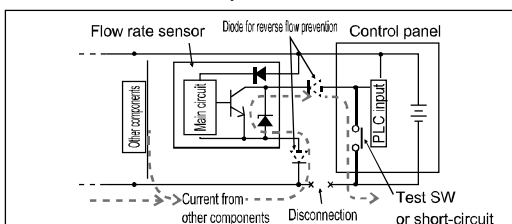

- Take the following measures to prevent damage caused by reverse current.
 - Avoid centralizing current at the power cable, especially the minus side power cable, and use as thick a cable as possible.
 - Limit the number of devices connected to the same power source as the flow rate sensor.
 - Insert a diode parallel to the flow rate sensor's output line to prevent reverse current.
 - Insert a diode parallel to the flow rate sensor power wire's negative (-) side to prevent reverse current.
- Pay attention to surge current leading. When flow rate sensor power is shared with an inductive load that generates surges, such as a solenoid valve or relay, if the circuit is cut off while the inductive load is functioning, surge current could enter the switch output circuit and cause damage depending on where the surge absorbing element is installed.

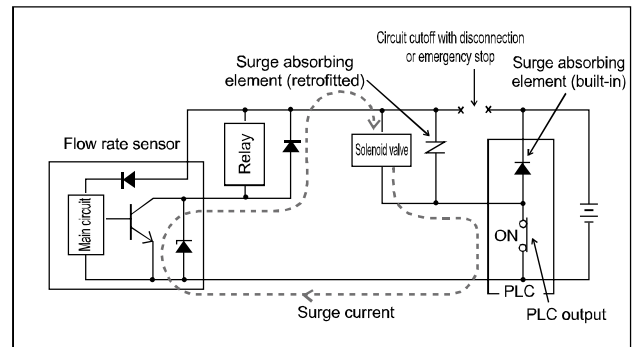

Take the measures below to prevent damage from sneak surge current.

- Separate the power supply for output including the inductive load, such as the solenoid valve and relay, and input, such as the flow rate sensor.
- If a separate power supply cannot be used, directly install a surge absorption element for all inductive loads. Consider that the surge absorption element connected to the PLC, etc., protects only the individual device.
- Connect a surge absorption element to places on the power wiring shown in the figure below, as a measure against disconnections in unspecified areas.

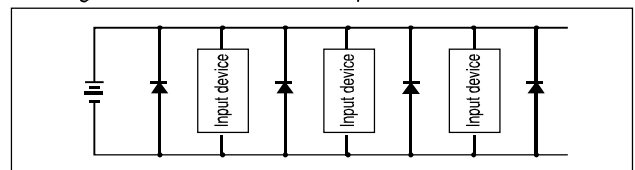

When the devices are connected to a connector, the output circuit could be damaged by the above phenomenon if the connector is disconnected while the power is ON. Turn power OFF before connecting or disconnecting the connector.

- Analog output continues even if the flow rate range is exceeded. With the display integrated, "Hi" or "Lo" will be displayed. With the display separated, the bar display will flicker. Note that this is outside guaranteed precision.
- When using the integrated display model, do not press down on the display section. This may lead to failure.
- The accuracy may vary from the initial status depending on the working environment or working conditions. It is recommended to check the operation of the product periodically.
- The sensor chip will degrade when used for a long time and cause the detected flow rate to fluctuate. Periodically inspect the sensor chip.
- Working conditions for CE compliance
This product is CE-marked, indicating conformity with the EMC Directives. The standard for the immunity for industrial environments applied to this product is EN61000-6-2; the following requirements must be satisfied in order to conform to this standard: Conditions
 - The assessment of this product is performed by using a cable pairing a power supply line and a signal line, assessing this cable as a signal line.
 - This product is not equipped with surge immunity. Implement surge protection measures on the system side.

F.R.L
F (Filtr)
R (Reg)
L (Lub)
PresSW
Shutoff
SlowStart
FmResistFR
Oil-ProhR
MedPresFR
No Cu/ PTFE FRL
Outdrs FR
F.R.L (Related)
CompFRL
LgFRL
PrecsR
VacF/R
Clean FR
ElecPneuR
AirBoost
SpdContr
SilIncr
CheckV/ other
Jnt/tube
AirUnt
PresCompn
Mech/ ElecPresSw
ContactSW
AirSens
PresSW Cool
AirFloSens/ Contr
WaterPtSens
TotAirSys (Total Air)
TotAirSys (Gamma)
RefrDry
DesicDry
HiPolymDry
MainFiltr
Dischrg etc
Ending

F.R.L Product-specific cautions: Needle valve integrated FSM2-□N Series

F (Filtr)
R (Reg)
L (Lub)
PresSW
Shutoff
SlowStart
FmResisFR
Oil-ProhR
MedPresFR
No Cu/ PTFE FRL
Outdrs FR
F.R.L (Related)
CompFRL
LgFRL
PrecsR
VacF/R
Clean FR
ElecPneuR
AirBoost
SpdContr
SiIncr
CheckV/ other
Jnt/tube
AirUnt
PrecsCompn
Mech/ ElecPresSw
ContactSW
AirSens
PresSW Cool
AirFloSens/ Contr
WaterRtSens
TotAirSys (Total Air)
TotAirSys (Gamma)
RefrDry
DesicDry
HiPolymDry
MainFiltr
Dischrg etc
Ending

Design/selection

⚠ CAUTION

- This valve cannot be used as a stop valve that requires no leakage. Slight leakage is allowed for in this product's specifications.

- The flow path in the needle valve is not completely free of dust generation. A final clean filter should be used in circuits where dust generation could be a problem.

Mounting, installation and adjustment

⚠ CAUTION

- Do not turn the dial forcibly when fully closing or opening it (0.05 N·m or less). Do not use the lock nut to adjust the needle. Otherwise this could cause needle galling or damage.

- The set flow rate may vary if turning the dial of the needle valve forcibly when fully closing. Take care not to turn the dial forcibly when setting a very small flow rate.

Use/maintenance

⚠ CAUTION

- Vibration could cause the needle to turn and the flow rate to change.

Product-specific cautions: Separated display FSM2-D Series

Design/selection

⚠ CAUTION

- The corresponding sensor is the voltage output (1 to 5 V). If the current output or other voltage output is connected, it doesn't operate properly. Use the FSM2-AV when using the FSM2.

Mounting, installation and adjustment

⚠ CAUTION

- Cut the half-strip section at the end of the e-con connector wiring before use. Insert the wire through to the back of the connector, and securely crimp with pliers, etc. The wire sheath does not need to be removed. Check that the pin No. and wire color are correct before crimping. Incorrect wiring can lead to sensor or separated display damage, faults or malfunction.

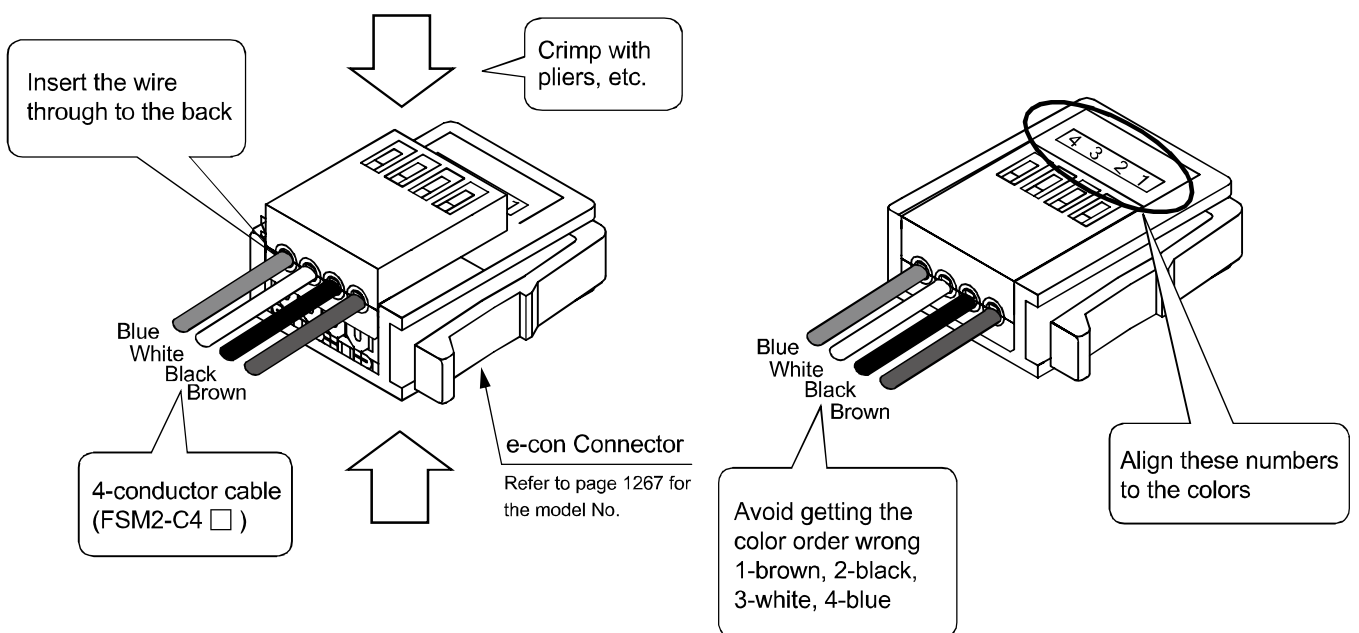

* The e-con connector is enclosed with the separated display.

- When attaching or removing the cable, hold the connector instead of the cable. Holding the cable could result in a contact fault, broken wire, short-circuit, etc., could damage the sensor or separated display, or cause malfunctions.
- Do not apply a load of 15 N or over on the cable.

F.R.L
F (Filtr)
R (Reg)
L (Lub)
PresSW
Shutoff
SlowStart
FmResistFR
Oil-ProhR
MedPresFR
No Cu/ PTFE FRL
Outdrs FR
F.R.L (Related)
CompFRL
LgFRL
PrecsR
VacF/R
Clean FR
ElecPneuR
AirBoost
SpdContr
Silncr
CheckV/ other
Jnt/tube
AirUnt
PrecsCompn
Mech/ ElecPresSw
ContactSW
AirSens
PresSW Cool
AirFloSens/ Contr
WaterPtSens
TotAirSys (Total Air)
TotAirSys (Gamma)
RefrDry
DesicDry
HiPolymDry
MainFiltr
Dischrg etc
Ending

Flow sensor for compressed air

PFD/PFK (Display separated FLUEREX flow sensor)

■ Sensors/controller/flow rate sensor

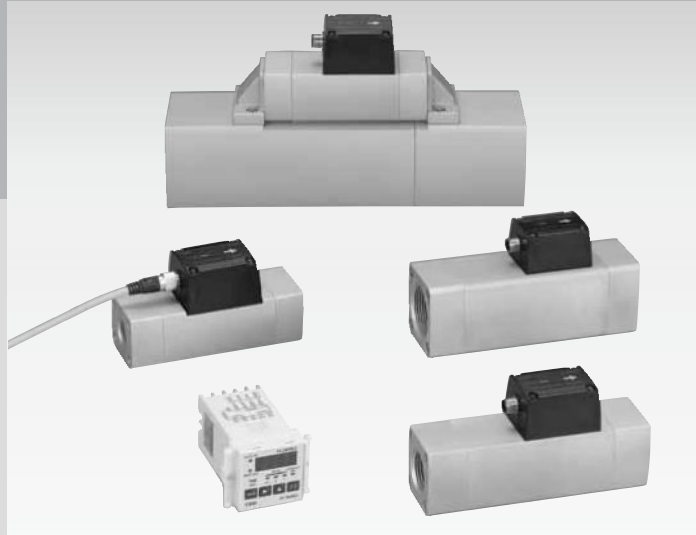

CONTENTS

Product introduction	1394
Applications	1396
● FLUEREX flow sensor (PFD) display separated	1398
● Tester kit (PFK)	1404
Electric wiring	1408
Functions/operations for monitor	1410
▲ Safety precautions	1412

F.R.L
F (Filtr)
R (Reg)
L (Lub)
PresSW
Shutoff
SlowStart
FhiResistFR
Oil-ProhR
MedPresFR
No Cu/ PTFE FRL
Outdrs FR
F.R.L (Related)
CompFRL
LgFRL
PrecsR
VacF/R
Clean FR
ElecPneuR
AirBoost
SpdContr
Silncr
CheckV/ other
Jnt/tube
AirUnt
PresCompn
Mech/ ElecPresSw
ContactSW
AirSens
PresSW Cool
AirFloSens/ Contr
WaterPtSens
TotAirSys (Total Air)
TotAirSys (Gamma)
RefrDry
DesicDry
HiPolymDry
MainFiltr
Dischrg etc
Ending

F.R.L
F (Filtr)
R (Reg)
L (Lub)
PresSW
Shutoff
SlowStart
FmResistFR
Oil-ProhR
MedPresFR
No Cu/ PTFE FRL
Outdrs FR
F.R.L (Related)
CompFRL
LgFRL
PrecsR
VacF/R
Clean FR
ElecPneR
AirBoost
SpdContr
SiIncr
CheckV/ other
Jnt/tube
AirUnt
PrecsCompn
Mech/ ElecPresSw
ContactSW
AirSens
PresSW Cool
AirFloSens/ Contr
WaterRtSens
TotAirSys (Total Air)
TotAirSys (Gamma)
RefrDry
DesicDry
HiPolymDry
MainFiltr
Dischrg etc
Ending

Contributing to the global environment with energy saving control.

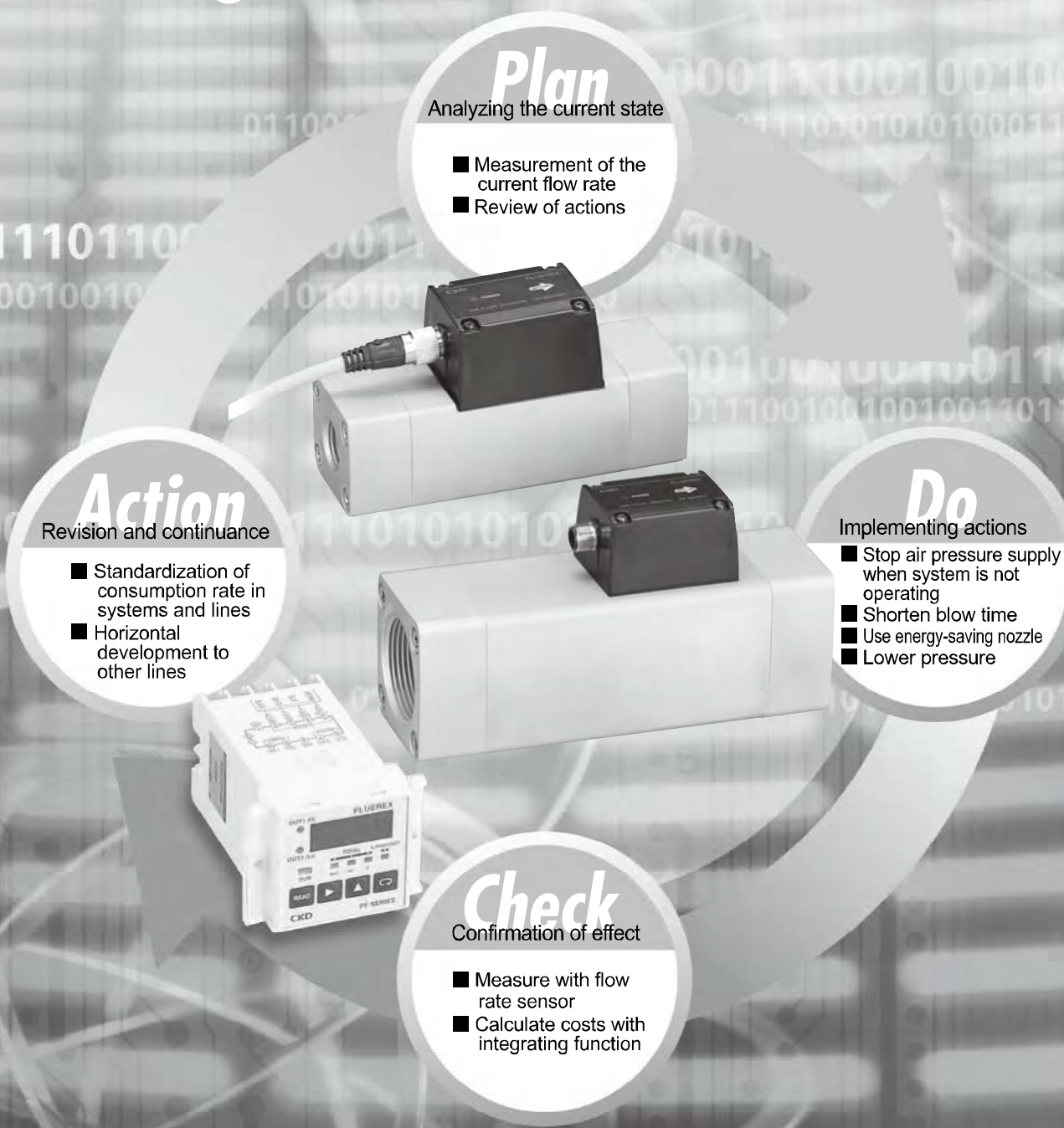

Plan

Analyzing the current state

- Measurement of the current flow rate
- Review of actions

Action

Revision and continuance

- Standardization of consumption rate in systems and lines
- Horizontal development to other lines

Do

Implementing actions

- Stop air pressure supply when system is not operating
- Shorten blow time
- Use energy-saving nozzle
- Lower pressure

Check

Confirmation of effect

- Measure with flow rate sensor
- Calculate costs with integrating function

Flow rate sensor for compressed air

FLUEREX PFD Series



PFD Series FLUEREX flow rate sensor for compressed air assists in analyzing current energy consumption and confirming the effect.

Ample output variations

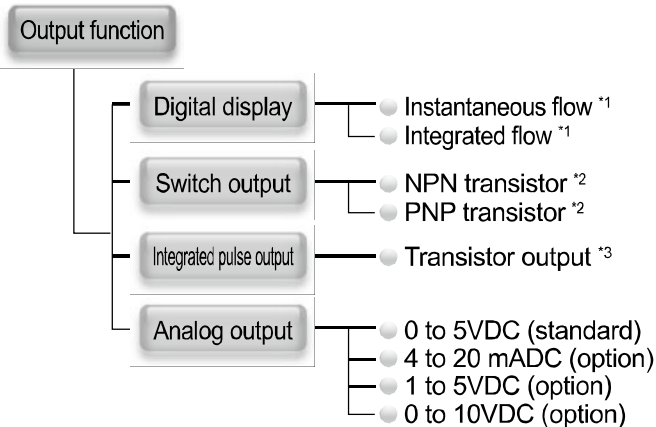

- *1. Switch between the instantaneous flow and integrated flow with a single touch.
- *2. Select NPN or PNP for the switch output. Two output points are provided. (PFK Series has 1 point)
- *3. Change one of the switch outputs to an integrated pulse output with easy operation.



RoHS Directive compliant

All substances, such as lead and hexavalent chrome, which could adversely affect the global environment, have been completely eliminated from the materials used in this controller.



Optimum for ISO 14001 acquisition

The lineup includes a large flow which supports energy saving control in factory units. This device is essential for acquiring ISO14001, the International Standardization Standard for environment management systems.

Directly read digital displays with no need for calibration

Since bothersome pressure correction and temperature compensation are not required, the digital display value can be read and used.

- Pressure correction not required
Method of detecting weight flow adopted
- Temperature correction not required
Automatic temperature compensation function built in

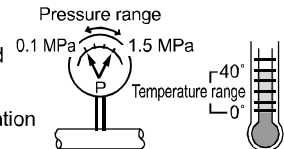

High precision with general precision of ±4%F.S.

General precision of ±4%F.S. is realized in a temperature range of 10 to 30°C and pressure range of 0.2 to 0.7 MPa even without calibration.

$$\text{Total precision} = \pm \sqrt{(\text{linearity})^2 + (\text{temperature characteristics})^2 + (\text{pressure characteristics})^2}$$

(Note) The general precision is the reference value including all errors including the errors from temperature or pressure variation and the linearity, etc.

Convenient portable kit available

Five types of tester kits consisting of a sensor section, monitor section and piping, etc., in a trunk case are available.

- Piping and wiring can be changed with a single touch.



Covering a wide range of flow rates with 11 types

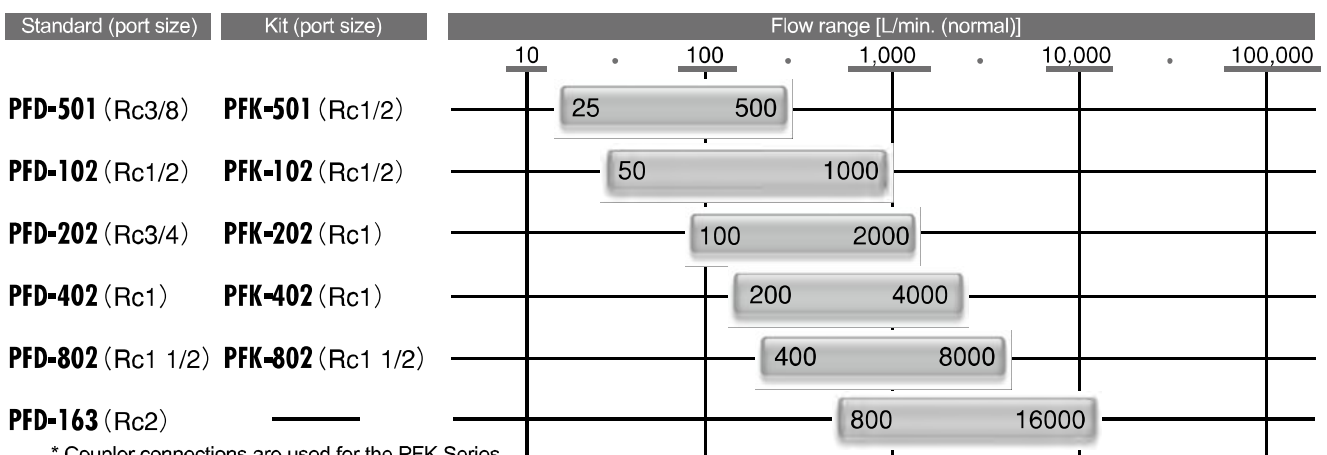

* Coupler connections are used for the PFK Series.

- F.R.L
- F (Filtr)
- R (Reg)
- L (Lub)
- PresSW
- Shutoff
- SlowStart
- FhiResistFR
- Oil-ProhR
- MedPresFR
- No Cu/ PTFE FRL
- Outdrs FR
- F.R.L (Related)
- CompFRL
- LgFRL
- PrecsR
- VacF/R
- Clean FR
- ElecPneuR
- AirBoost
- SpdContr
- Silncr
- CheckV/ other
- Jnt/tube
- AirUnt
- PresCompn
- Mech/ ElecPresSw
- ContactSW
- AirSens
- PresSW Cool
- AirFloSens/ Contr
- WaterPtSens
- TotAirSys (Total Air)
- TotAirSys (Gamma)
- RefrDry
- DesicDry
- HiPolymDry
- MainFiltr
- Dischrg etc
- Ending

F.R.L
F (Filtr)
R (Reg)
L (Lub)
PresSW
Shutoff
SlowStart
FlmResistFR
Oil-ProhR
MedPresFR
No Cu/ PTFE FRL
Outdrs FR
F.R.L (Related)
CompFRL
LgFRL
PrecsR
VacFR
Clean FR
ElecPneuR
AirBoost
SpdContr
Silncr
CheckV/ other
Jnt/tube
AirUnt
PrecsCompn
Mech/ ElecPresSw
ContactSW
AirSens
PresSW Cool
AirFloSens/ Contr
WaterRtSens
TotAirSys (Total Air)
TotAirSys (Gamma)
RefrDry
DesicDry
HiPolymDry
MainFiltr
Dischrg etc
Ending

Applications of flow sensor for compressed air

For flow rate management of production line of an auto plant

■ Auto line control

■ Paint line robot

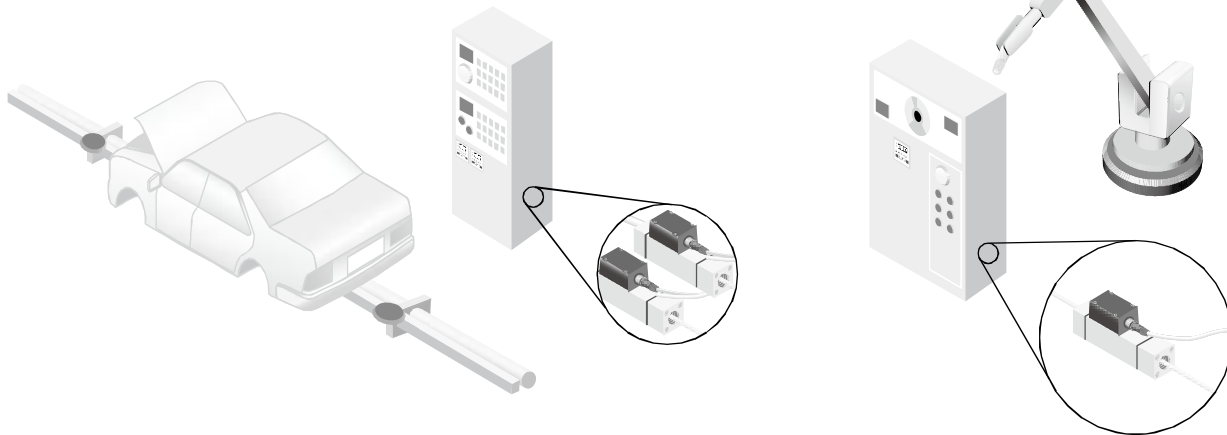

For flow rate management of FPD manufacturing equipment

■ Ionizer

■ Air knife

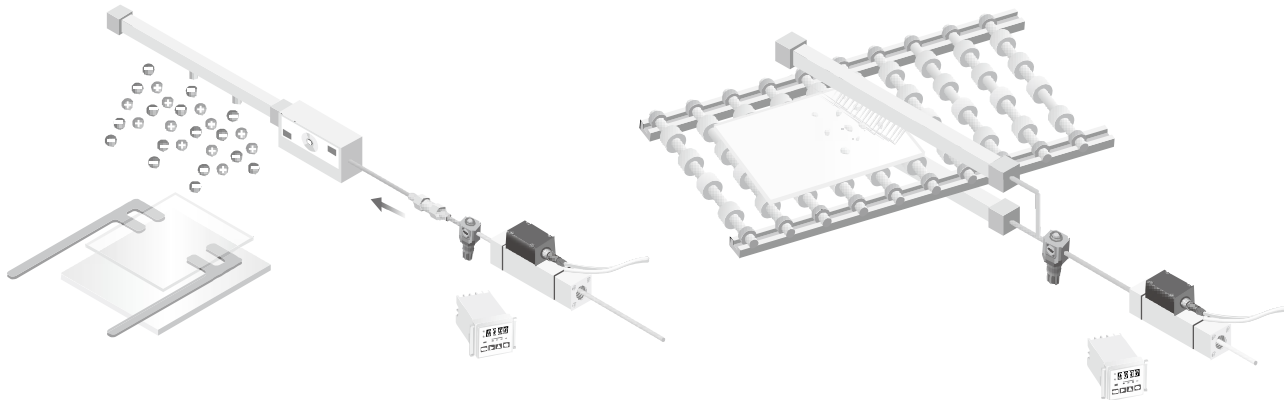

Functions

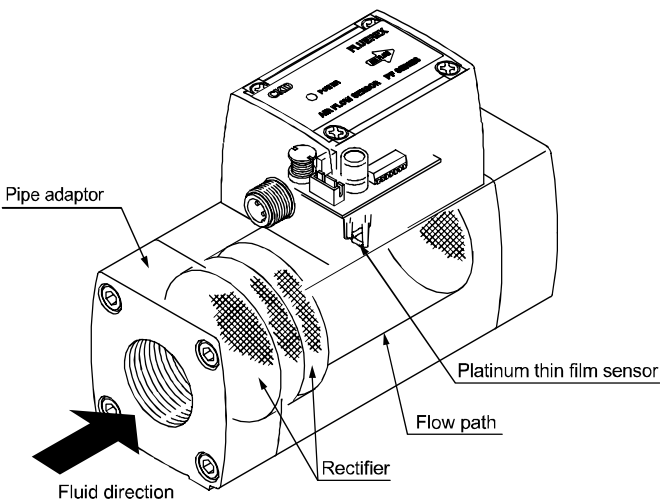

The sensor of FLUEREX consists of a rectifier that converts the compressed air to a uniform flow and a platinum thin film resistor that detects the flow rate. The rectifier works to make the flow uniform when a bent pipe such as an elbow is installed immediately before the sensor. Through the use of multiple rectification plates, the pressure loss is suppressed and an adequate rectification effect is realized. When the compressed air does not flow, the platinum thin film sensor that detects the flow rate is heated from the fluid temperature to a certain constant temperature. When the compressed air flows, the amount of heat proportional to the weight of air is detracted and the current that intends to maintain the constant temperature flows in the circuit inside the platinum thin film sensor that detects the flow rate. By receiving this current as a flow rate signal, the display section displays a practical atmospheric pressure, instantaneous flow rate or integrating flow of the air converted to 0°C. In addition, by the platinum thin film sensor that detects the fluid temperature, the temperature of the compressed air is measured and the temperature correction is performed.

MEMO

F.R.L
F (Filtr)
R (Reg)
L (Lub)
PresSW
Shutoff
SlowStart
FmResistFR
Oil-ProhR
MedPresFR
No Cu/ PTFE FRL
Outdrs FR
F.R.L (Related)
CompFRL
LgFRL
PrecsR
VacF/R
Clean FR
ElecPneuR
AirBoost
SpdContr
Silncr
CheckV/ other
Jnt/tube
AirUnt
PresCompn
Mech/ ElecPresSw
ContactSW
AirSens
PresSW Cool
AirFloSens/ Contr
WaterPtSens
TotAirSys (Total Air)
TotAirSys (Gamma)
RefrDry
DesicDry
HiPolymDry
MainFiltr
Dischrg etc
Ending

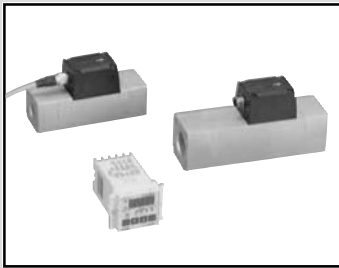

FLUEREX flow sensor

PFD Series

- Flow rate range: 25 to 500, 50 to 1000, 100 to 2000, 200 to 4000
400 to 8000, 800 to 16000 L/min (normal)



Features

- Total accuracy The flow rate is detected with $\pm 4\%$ F.S.
- The correction due to pressure fluctuation or temperature fluctuation is not required.
- The flow rate converted to the reference state (0°C , 101.3 kPa) is displayed.
- The integration display and integrated value pulse output are possible.
- A wide range of functions and variations such as flow rate range and various electric outputs.

Specifications

Descriptions	PFD-501-10	PFD-102-15	PFD-202-20	PFD-402-25	PFD-802-40	PFD-163-50
Specs						
Flow rate range L/min(normal)	25 to 500	50 to 1000	100 to 2000	200 to 4000	400 to 8000	800 to 16000
Port size	Rc3/8	Rc1/2	Rc3/4	Rc1	Rc1 1/2	Rc2
Working conditions	Compressed clean air/nitrogen gas					
Applicable fluid	Compressed clean air/nitrogen gas					
Air quality	JIS B8392-1: 2012 (ISO 8573-1: 2010) [1:1:1 - 1:6:1] (*1)					
Max. working pressure MPa	1.0 (≈ 150 psi, 10 bar)					
Min. working pressure MPa	0.1 (≈ 15 psi, 1 bar)					
Proof pressure MPa	1.5 (≈ 220 psi, 15 bar)					
Ambient temperature $^\circ\text{C}$	0 (32°F) to 50 (122°F)					
Ambient humidity	85% R.H. or less (no condensation)					
Fluid temperature $^\circ\text{C}$	0 (32°F) to 40 (104°F)					
Accuracy	$\pm 3.0\%$ F.S. (0.5 MPa (≈ 73 psi, 5 bar), at 20°C (68°F))					
Linearity	$\pm 3.0\%$ F.S. (0.5 MPa (≈ 73 psi, 5 bar), at 20°C (68°F))					
Pressure characteristics	$\pm 2.0\%$ F.S. (0.5 MPa (≈ 73 psi, 5 bar) reference, at 0.2 (≈ 29 psi, 2 bar) to 0.7 MPa (≈ 100 psi, 7 bar))					
Temperature characteristics	$\pm 2.0\%$ F.S. (20°C (68°F) reference, at 10 (50°F) to 30°C (86°F))					
Pressure loss MPa	0.015 (≈ 2.2 psi, 0.15 bar) or less (max. flow rate, at 0.5 MPa (≈ 73 psi, 5 bar))					
Response time sec	2.5 or less					
Output	Instant/integrating flow 4-digit LED display					
Display	Instant/integrating flow 4-digit LED display					
Resolution L/min(normal)	1	5	5	10	20	50
Min. displayed flow rate L/min(normal)	10	20	40	80	160	320
Integrating flow	Max. 9 digits (switching display using change key) (*4)					
Analog output	Standard: 0 to 5 VDC/option: 4 to 20 mA DC, 1 to 5 V, 0 to 10 V					
Switch output	2 points (NPN/PNP transistor output: selection)					
Pulse output (*2)	10 L(normal)/pulse			100 L(normal)/pulse		
Power supply voltage V	24 VDC (6 W or less/excluding load current of switch output)					
Cable	Accessory (3 m, 4-conductor, finish diameter $\phi 6$, cable conductor 0.5 mm ² , insulator O.D. 1.72 mm, with connector)					
Mounting	Unrestricted in vertical/horizontal directions					
Mounting orientation	Unrestricted in vertical/horizontal directions					
Straight piping section	IN side: 10D, OUT side: 5D, these are recommended (*3)					
Degree of protection	IP64 equivalent (only for sensor)					
Weight	kg	1.1	1.1	1.3	1.4	1.7
Weight	kg	1.1	1.1	1.3	1.4	1.7
Bracket weight g	61 (including screws)				92 (including screws)	
Bracket weight g	61 (including screws)				92 (including screws)	

*1 : Note that condensation may be formed when used in a state with ambient temperature lower than fluid temperature.

Be careful that detection failure may occur if transmitted oil is accumulated. Because this kit does not have clean specifications for equipment, the generation of particles occurs on the secondary side. When the ultra clean air is required, it is recommended to install a filter for precise filtration on the end side.

*2 : The pulse output is shared with the switch output. Use this output by switching the function.

*3 : Providing straight piping sections is recommended so that the piping conditions do not affect the performance (D is inner diameter of the pipe).

*4 : The data of integrating flow value is backed up regularly. It can also be backed up by operation. Refer to "Functions/operations" on page 1410 for details.

How to order

● Display separated

PFD- 501 - 10 N 0 - B

A Flow rate range

B Port size

C Switch output

D Analog output

E Bracket (*1)

Code	Content						
A Flow rate range							
501	25 to 500 L /min(normal)						
102	50 to 1000 L /min(normal)						
202	100 to 2000 L /min(normal)						
402	200 to 4000 L /min(normal)						
802	400 to 8000 L /min(normal)						
163	0.80 to 16.00 m ³ /min(normal)						
B Port size							
	Flow rate range	501	102	202	402	802	163
10	Rc3/8	●					
15	Rc1/2		●				
20	Rc3/4			●			
25	Rc1				●		
40	Rc1 1/2					●	
50	Rc2						●
C Switch output							
N	NPN transistor output x 2						
P	PNP transistor output x 2						
D Analog output							
0	0 to 5 VDC	Standard					
1	4 to 20 mADC	Option					
2	1 to 5 VDC	Option					
3	0 to 10 VDC	Option					
E Bracket							
Blank	None	Standard					
B	Bracket attached	Option					

⚠ Precautions for model No. selection

*1: Bracket option is not available for PFD-163.

*2: The product consists of sensor, monitor and cable.
The description on the plate is as follows.
The model No. is not indicated on the cable.

Product : PFD-(A) (B) (C) (D)-(E)
Sensor section: PFD-(A)-(B)
Monitor: PFD-(A)-(C) (D)

[Example of model No.]

PFD-501-10N0-B

Model: PFD

- A** Flow rate range: 25 to 500 L/min (normal)
- B** Port size : Rc3/8
- C** Switch output : NPN transistor output
- D** Analog output : 0 to 5 VDC
- E** Bracket : Attached

● Discrete option model No.

PFD-C3

Code	Descriptions
C3	Standard cable
CW	Extension cable (cable for PFK)
B	Bracket (for 501/102/202/402)
B1	Bracket (for 802)

F.R.L
F (Filtr)
R (Reg)
L (Lub)
PresSW
Shutoff
SlowStart
FhiResistFR
Oil-ProhR
MedPresFR
No Cu/ PTFE FRL
Outdrs FR
F.R.L (Related)
CompFRL
LgFRL
PrescR
VacF/R
Clean FR
ElecPneuR
AirBoost
SpdContr
Silncr
CheckV/ other
Jnt/tube
AirUnt
PresCompn
Mech/ ElecPresSw
ContactSW
AirSens
PresSW Cool
AirFloSens/ Contr
WaterPtSens
TotAirSys (Total Air)
TotAirSys (Gamma)
RefrDry
DesicDry
HiPolymDry
MainFiltr
Dischrg etc
Ending

F.R.L
F (Filtr)
R (Reg)
L (Lub)
PresSW
Shutoff
SlowStart
FlmResistFR
Oil-ProhR
MedPresFR
No Cu/
PTFE FRL
Outdrs FR
F.R.L
(Related)
CompFRL
LgFRL
PrecsR
VacF/R
Clean FR
ElecPneR
AirBoost
SpdContr
Silncr
CheckV/
other
Jnt/tube
AirUnt
PrecsCompn
Mech/
ElecPresSw
ContactSW
AirSens
PresSW
Cool
AirFloSens/
Contr
WaterRtSens
TotAirSys
(Total Air)
TotAirSys
(Gamma)
RefrDry
DesicDry
HiPolymDry
MainFiltr
Dischrq
etc
Ending

Internal structure and parts list

● PFD-501 to PFD-802

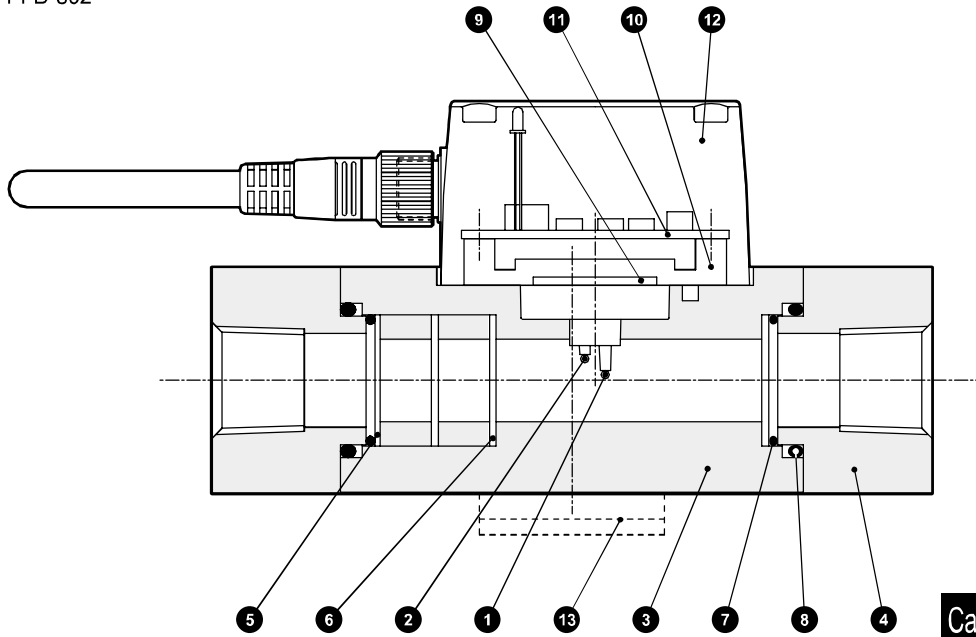

No.	Part name	Material	No.	Part name	Material
1	Platinum thin film sensor 1	Alumina/platinum	7	O-ring	NBR Nitrile rubber
2	Platinum thin film sensor 2	Alumina/platinum	8	O-ring	NBR Nitrile rubber
3	Body	A6063S Aluminum alloy	9	Sensor base board	Glass epoxy
4	Adaptor	A6063S Aluminum alloy	10	Sensor base	PBT Polybutylene terephthalate
5	Rectification plate	SUS304 Stainless steel	11	Sensor board	Glass epoxy
6	Mesh	SUS304 Stainless steel	12	Cover	ABS ABS resin
			13	Bracket	SUS304 Stainless steel

● PFD-163

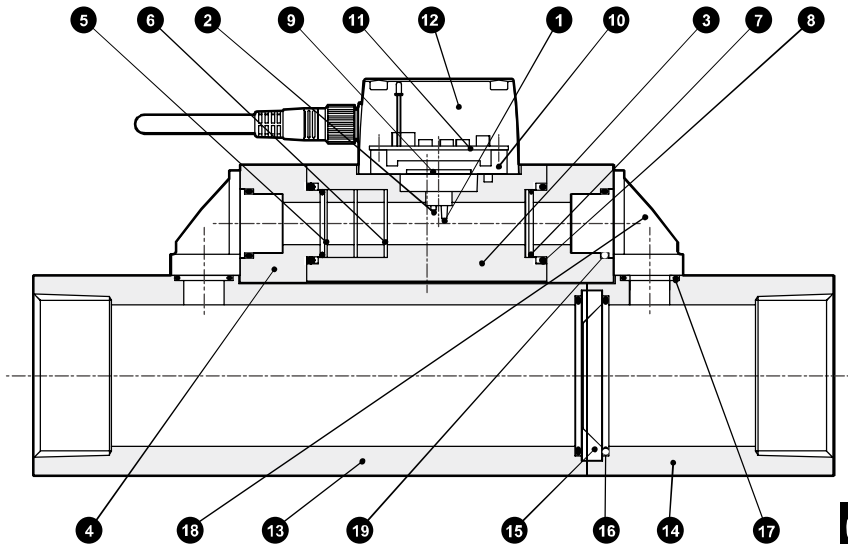

No.	Part name	Material	No.	Part name	Material
1	Platinum thin film sensor 1	Alumina/platinum	11	Sensor board	Glass epoxy
2	Platinum thin film sensor 2	Alumina/platinum	12	Cover	ABS ABS resin
3	Body	A6063S Aluminum alloy	13	Flow path 1	A6063S Aluminum alloy
4	Split-flow adaptor	A6063S Aluminum alloy	14	Flow path 2	A6063S Aluminum alloy
5	Rectification plate	SUS304 Stainless steel	15	Orifice	C3604BD Copper alloy
6	Mesh	SUS304 Stainless steel	16	O-ring	NBR Nitrile rubber
7	O-ring	NBR Nitrile rubber	17	O-ring	NBR Nitrile rubber
8	O-ring	NBR Nitrile rubber	18	Sub-attachment	SCS13 Stainless steel
9	Sensor base board	Glass epoxy	19	O-ring	NBR Nitrile rubber
10	Sensor base	PBT Polybutylene terephthalate			

Dimensions

● PFD-501 to 802

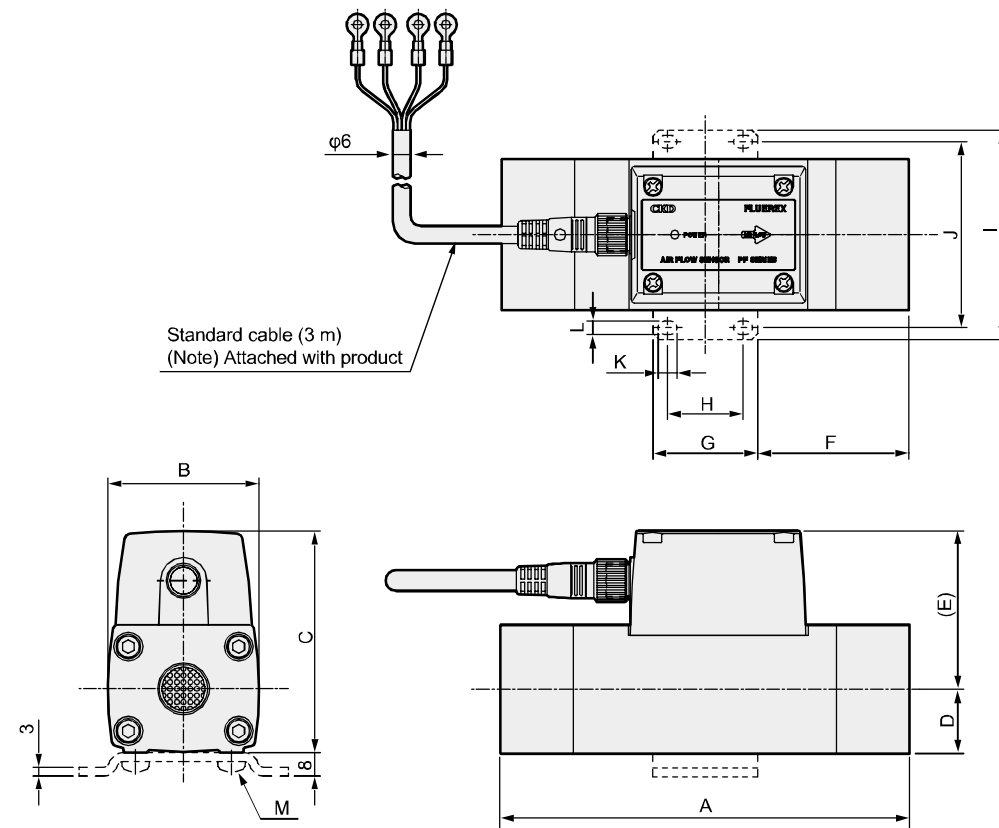

Model No.	Port size
PFD-501-10	Rc3/8
PFD-102-15	Rc1/2
PFD-202-20	Rc3/4
PFD-402-25	Rc1
PFD-802-40	Rc1 1/2

Model No.	A	B	C	D	(E)	F	G	H	I	J	K	L	M
PFD-501/102	140	52	76.2	22	54.2	52	36	26	72	64	6.5	4.5	M4 thread depth 6
PFD-202	150	55	87.2	27.5	59.7	57	36	26	72	64	6.5	4.5	M4 thread depth 6
PFD-402	175	55	90.7	27.5	63.2	69.5	36	26	72	64	6.5	4.5	M4 thread depth 6
PFD-802	190	65	103.7	34	69.7	75	40	26	94	80	8	6	M5 thread depth 8

● Monitor section

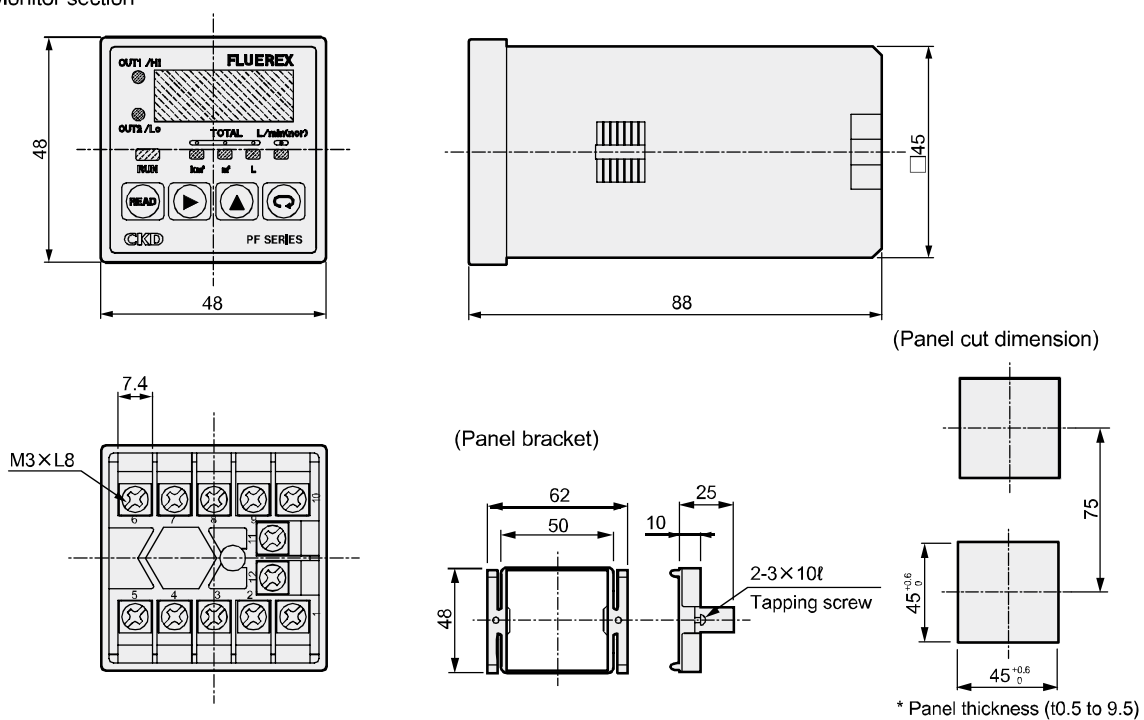

F.R.L
F (Filtr)
R (Reg)
L (Lub)
PresSW
Shutoff
SlowStart
FmResistFR
Oil-ProhR
MedPresFR
No Cu/ PTFE FRL
Outdrs FR
F.R.L (Related)
CompFRL
LgFRL
PrecsR
VacF/R
Clean FR
ElecPneuR
AirBoost
SpdContr
Silncr
CheckV/ other
Jnt/tube
AirUnt
PresCompn
Mech/ ElecPresSw
ContactSW
AirSens
PresSW Cool
AirFloSens/ Contr
WaterPtSens
TotAirSys (Total Air)
TotAirSys (Gamma)
RefrDry
DesicDry
HiPolymDry
MainFiltr
Dischrg etc
Ending

PFD Series



Dimensions

● PFD-163

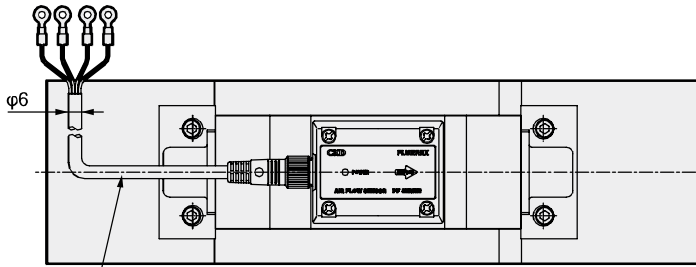

Standard cable (3 m)
(Note) Attached with product

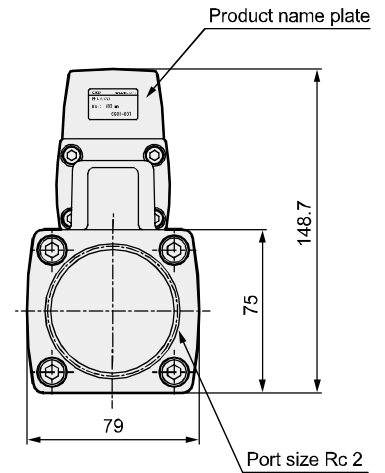
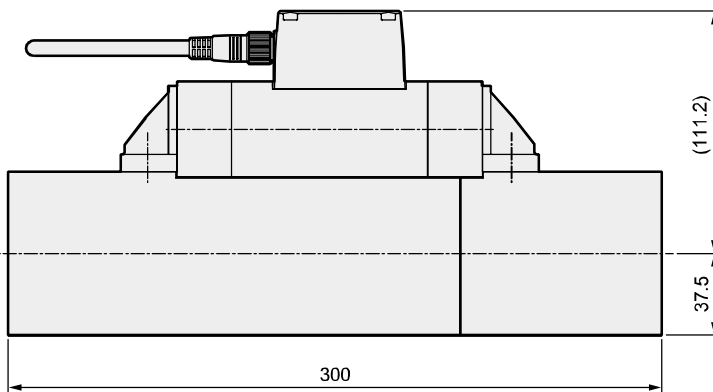

F.R.L
F (Filtr)
R (Reg)
L (Lub)
PresSW
Shutoff
SlowStart
FmResistFR
Oil-ProhR
MedPresFR
No Cu/ PTFE FRL
Outdrs FR
F.R.L (Related)
CompFRL
LgFRL
PrecsR
VacF/R
Clean FR
ElecPneuR
AirBoost
SpdContr
SiIncr
CheckV/ other
Jnt/tube
AirUnt
PrecsCompn
Mech/ ElecPresSw
ContactSW
AirSens
PresSW Cool
AirFloSens/ Contr
WaterRtSens
TotAirSys (Total Air)
TotAirSys (Gamma)
RefrDry
DesicDry
HiPolymDry
MainFiltr
Dischrg etc
Ending

MEMO

F.R.L
F (Filtr)
R (Reg)
L (Lub)
PresSW
Shutoff
SlowStart
FmResistFR
Oil-ProhR
MedPresFR
No Cu/ PTFE FRL
Outdrs FR
F.R.L (Related)
CompFRL
LgFRL
PrecsR
VacF/R
Clean FR
ElecPneuR
AirBoost
SpdContr
Silncr
CheckV/ other
Jnt/tube
AirUnt
PresCompn
Mech/ ElecPresSw
ContactSW
AirSens
PresSW Cool
AirFloSens/ Contr
WaterPtSens
TotAirSys (Total Air)
TotAirSys (Gamma)
RefrDry
DesicDry
HiPolymDry
MainFiltr
Dischrg etc
Ending



Pneumatic components (sensors)

Safety Precautions

Be sure to read this section before use.

Refer to Intro Page 63 for general precautions regarding pneumatic components and refer to "⚠ Safety precautions" for detailed precautions for individual series.

Product-specific cautions: Flow sensor for compressed air PFD series

Design/selection

1. Checking the specifications

⚠ DANGER

- Never use with a flammable fluid.

⚠ WARNING

- Use the product in the range of conditions specified for the product. The product in this catalog is designed for use only in a compressed air system. Use with pressures or temperatures outside the specifications range may result in damage or operation failure.

- This product cannot be used as a billing meter. Do not use this product for commercial transactions as it is not compliant with the Measurement Act. Intended applications include industrial sensors.

- Because compressed air or nitrogen gas is used as an applicable fluid, do not use fluids other than these, because accuracy cannot be guaranteed.

2. Safety design

⚠ WARNING

- Take measures to prevent physical harm or property damage in the event of failure of this product.

⚠ CAUTION

- Understand the characteristics of compressed air before designing a pneumatic circuit.
 - Pop-out, air discharge, or leakage due to air compression and expansion may occur.
 - Design the circuit so that compressed air in the system is exhausted.

- Check for leakage current to avoid malfunction caused by the leakage current.

- When using a programmable controller, leakage current may cause malfunction.

- Because both the sensor and monitor of this product are independent, they can be replaced with a model that has the same flow rate range.

- They cannot be replaced with a model that has a different flow rate range.
- The sensor and monitor must be used in a set. By using only either one of them, this kit does not operate.

- Although there is no movable section in the flow rate sensor, when repeating ON/OFF of the solenoid valve, the mesh section or fixed section of the rectifier may move slightly and this may result in the generation of particles. When the generation of particles must be eliminated, be sure to install a filter on the secondary side (downstream side) of the flow rate sensor.

3. Design by application

⚠ CAUTION

- Exerts no influence on performance as it uses compressed air and a small amount of leakage is tolerable. Contact CKD if no leakage is tolerable.

4. Working environment

⚠ DANGER

- Never use this product in an explosive gas atmosphere. The structure is not explosion-proof, and explosions or fires could occur.

- When using nitrogen gas as an applicable fluid, oxygen deficiency could be caused. Observe the following instructions.
 - (1) Use in well ventilated locations.
 - (2) Ventilate the work area when nitrogen gas is being used.
 - (3) Inspect nitrogen gas piping regularly to avoid leaks.

⚠ WARNING

- Install the product where it will not be exposed to rain, water or direct sunlight.
- Do not use this product in a corrosive environment. Use in such an environment could lead to damage or operation failure.
- Consult with CKD if ozone is generated in the supplied air.
- Avoid using this product in environments where ozone is generated.
- Fluid temperature should be in the range of 0 to 40°C. Even if the ambient temperature is within the specified range, do not use this product in a location where the temperature could suddenly change and cause dew to condense.
- Do not use at a pressure exceeding the max. working pressure, as excessive pressure can cause product failure.

F.R.L
F (Filtr)
R (Reg)
L (Lub)
PresSW
Shutoff
SlowStart
FlmResistFR
Oil-ProhrR
MedPresFR
No Cu/ PTFE FRL
Outdrs FR
F.R.L (Related)
CompFRL
LgFRL
PrecsR
VacF/R
Clean FR
ElecPneUR
AirBoost
SpdContr
SiIncr
CheckV/ other
Jnt/tube
AirUnt
PrecsCompn
Mech/ ElecPresSw
ContactSW
AirSens
PresSW Cool
AirFloSens/ Contr
WaterRtSens
TotAirSys (Total Air)
TotAirSys (Gamma)
RefrDry
DesicDry
HiPolymDry
MainFiltr
Dischrg etc
Ending

- The sensor section employs a dust-proof, drip-proof structure that provides reliability during maintenance and cleaning, during which it may be exposed to water splashing. However, avoid using this product in a location where it may be constantly exposed to water or intense splattering of water and/or oil.

⚠ CAUTION

- Confirm before use that the product will withstand the working environment.
 - Cannot be used in environments where its functions will be impeded. Such environments include high temperatures, chemical atmospheres, or those where chemical liquids, vibration, moisture, dripping water, coolant or gas are present. Environments where ozone is generated.
- Be sure to use within ambient temperature range of 0 to 50°C.
- Do not use this product in an environment exposed to vibration resistance of 49 m/s² and over or shock resistance of 294 m/s² and over.

- Working conditions for CE compliance
This product is CE-marked, indicating conformity with the EMC Directives. The standard for the immunity for industrial environments applied to this product is EN61000-6-2; the following requirements must be satisfied in order to conform to this standard:
Conditions
 - The power cable connected to the terminal block must be less than 3 m long.
 - This product is not equipped with surge immunity. Implement surge protection measures on the system side.

5. Securing of space

⚠ WARNING

- Around the pneumatic component, keep space for installation, removal, wiring, and piping work.

Mounting, installation and adjustment

1. Installation

⚠ DANGER

- Use power supply voltage and output within the specified voltage. If voltage exceeding the specified voltage is applied, the sensor could malfunction or be damaged, or electrical shock or fire could occur. Do not use any load that exceeds the rated output. Otherwise, output damage or fire may result.

⚠ WARNING

- Check the line color and terminal number when connecting wires. Incorrect wiring could result in sensor damage and malfunctions, so check wire color and terminal number against the instruction manual before wiring. Install a noise filter if required.
- Ensure that wires are properly insulated. Check that wires do not come into contact with other circuits, that no ground faults occur, and that the insulator between terminals is not defective. Otherwise, overcurrent may flow into the sensor, causing damage.
- Keep the product away from high voltage cables, high voltage equipment and power equipment such as motors.
- Check that there are no cutting chips and wire dust on the terminal block of the monitor and the connector of the sensor before wiring.

⚠ CAUTION

- Do not remove the pneumatic component packaging and the piping port dust-proof cap until just before starting piping.
 - Removing the piping port cap before piping work may cause foreign matter to enter the pneumatic components from the piping port, resulting in failure or malfunction.
- When mounting pneumatic components, do not use a mounting method that relies on support from the piping.

2. Pre-operation confirmation

⚠ CAUTION

- After connecting piping, always check all pipe connections for air leaks before supplying compressed air.
 - Apply a leakage detection agent to pipe connections with a brush and check for air leaks. Make sure that the leak detection agent does not adhere to the resin parts. Otherwise resin parts could be damaged, which is dangerous.
- Keep the cable away from all noise sources, including power distribution wires. Noise can cause malfunctions.
- Do not short-circuit the output transistor. When a load is short-circuited, overcurrent protection circuit is triggered to prevent damage to the output transistor; however, if this state persists, the output transistor could be damaged.
- Do not use a load that can produce surge voltage. When directly running the load that generates a surge such as relay and solenoid valve, use a surge absorbing element built-in. If there is a surge source on the same power supply line, similarly implement surge protection.
- This product has no protection against lightning surge. This product is CE marking compliant but has no protection against lightning surge. For the protection against lightning surge, take countermeasures on the equipment side.
- Make sure that the lead wire is free of repeated bends and tension. This may lead to disconnection.
- For the wiring to the sensor and monitor, use the accessory cable (3 m). When extending the cable, contact your CKD branch or dealer.

F.R.L
F (Filtr)
R (Reg)
L (Lub)
PresSW
Shutoff
SlowStart
FniResistFR
Oil-ProhR
MedPresFR
No Cu/ PTFE FRL
Outdrs FR
F.R.L (Related)
CompFRL
LgFRL
PrescR
VacF/R
Clean FR
ElecPneuR
AirBoost
SpdContr
Silncr
CheckV/ other
Jnt/tube
AirUnt
PresCompn
Mech/ ElecPresSw
ContactSW
AirSens
PresSW Cool
AirFloSens/ Contr
WaterPtSens
TotAirSys (Total Air)
TotAirSys (Gamma)
RefrDry
DesicDry
HiPolymDry
MainFiltr
Dischrg etc
Ending

Mounting, installation and adjustment

3. Piping

CAUTION

- When connecting pipes, wrap sealing tape in the opposite direction from the threading, from the inside position to within 2 mm from the pipe end.
 - If sealing tape protrudes from the pipe threads, it could be cut when screwing the bolts in. This could cause the tape to enter the product, causing failures.

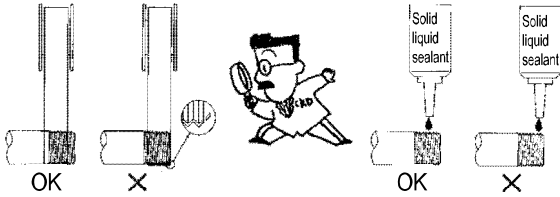

- When using a liquid sealant, make sure it does not adhere to resin parts. Otherwise resin parts could be damaged, which is dangerous.

- Check that the piping connected to the pneumatic components is not dislocated due to vibration, looseness, or tension.
 - Piping dislocation is dangerous.

- Observe the following precautions when using nylon tubes or urethane tubes for piping material.
 - Use flame-resistant tubes or metal steel pipes in an environment where spattering may occur.
 - When using the standard push-in fitting on the spiral tube, fix the base of the tube with a hose clamp. Rotation may occur, causing a reduction in holding force.

- Connect piping so that connections are not dislocated by equipment movement, vibration, or tension.

- Always flush just before piping pneumatic components.
 - Any foreign matter that has entered the pipes during piping must not enter the pneumatic components.

- Use appropriate torque to tighten the pipes when connecting them.
 - The purpose is to prevent air leakage and damage to bolts.
 - First tighten the bolts by hand to ensure that the threads are not damaged, then use a tool.

[Recommended values]

Port thread	Tightening torque N·m
Rc3/8	22 to 24
Rc1/2	28 to 30
Rc3/4	31 to 33
Rc1	36 to 38
Rc1 1/2	48 to 50
Rc2	54 to 56

- When adjusting the flow rate using a metering valve (glove valve, ball valve, etc.), install the metering valve on the secondary side (downstream side) of the sensor. Generated drift (turbulence in the flow) could cause errors.

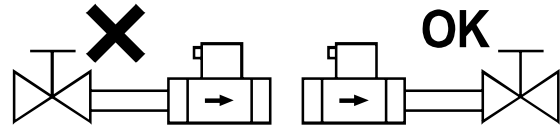

- Do not install the regulator immediately before the sensor. Generated drift may cause errors.
 - When installing the regulator on the primary side, provide a straight piping section of 10D and over.
 - * Where "D" indicates the inner diameter of the piping material.
 - Select a regulator that has sufficient margin of flow characteristics for the max. flow rate of the sensor.

- Align the fluid flow direction to the direction indicated on the sensor when connecting the pipes. When connecting it in reverse, the larger value is displayed.

- When using an elbow or bush in the piping, it is recommended to provide straight piping sections of 10D and over on the primary side and 5D and over on the secondary side.
 - For PFD-163 Series, be sure to provide straight piping sections.
 - Bore size change by bush should be limited to one size.

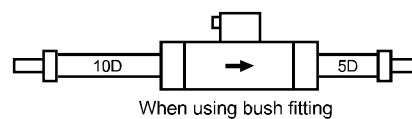
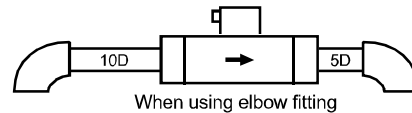

- Make sure that no force is applied to the resin parts when piping.

4. Pneumatic source

CAUTION

- Install a pneumatic filter just before the pneumatic component in the circuit.
- When supplying compressed air after connecting pipes, do not suddenly apply high pressure.
 - The pipe connection could dislocate, causing the pipe tube to fly out, leading to accidents.

■ Air quality

- Use CKD clean air system components appropriate for your application.
- Use compressed air that does not contain oil oxides, tar, carbon, etc., from the air compressor.
- Use compressed air that does not contain solid foreign matter.

- Install a filter, air dryer, and oil mist filter on the primary side (upstream side) of the sensor. The sensor's rectifier (mesh) rectifies the flow in the pipe. It does not filter out foreign matter, so provide a filter.

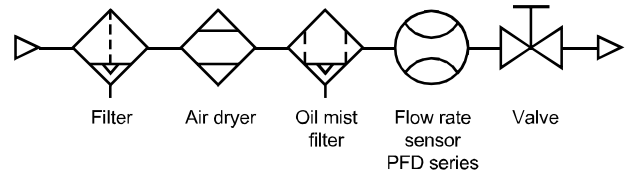

·When the ultra clean air is required

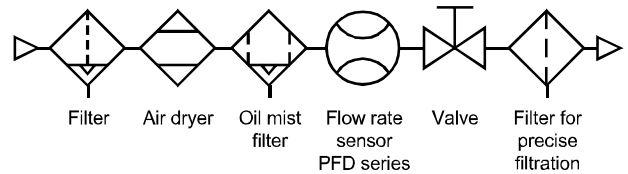

F.R.L
F (Filtr)
R (Reg)
L (Lub)
PresSW
Shutoff
SlowStart
PhiResistFR
Oil-ProhR
MedPresFR
No Cu/ PTFE FRL
Outdrs FR
F.R.L (Related)
CompFRL
LgFRL
PrecsR
VacF/R
Clean FR
ElecPneuR
AirBoost
SpdContr
Silncr
CheckV/ other
Jnt/tube
AirUnt
PresCompn
Mech/ ElecPresSw
ContactSW
AirSens
PresSW Cool
AirFloSens/ Contr
WaterPtSens
TotAirSys (Total Air)
TotAirSys (Gamma)
RefrDry
DesicDry
HiPolymDry
MainFiltr
Dischrg etc
Ending

Use/maintenance

1. When using the product

⚠ WARNING

- When suddenly opening the valve that connects to the sensor, fluid with a flow rate dozens of times greater than the rated flow rate may flow, and this can cause damage to the platinum thin film sensor or rectifier and flow out to the secondary side. When opening the valve that connects to the sensor, open it slowly so that the value in the monitor display may not exceed the rated flow rate.

⚠ CAUTION

- If a problem occurs during operation, immediately turn the power OFF, stop use, and contact your dealer.
- After the power supply is turned ON, internal settings such as hardware check are performed for 10 seconds. During this time, the display/output cannot operate normally. Particularly, if a switch output is used in the control of an interlock circuit, an abnormal stop may occur. Mask the output during this period.
- When changing the output set value, turn OFF the equipment first in order to prevent unexpected operation in the control system equipment.
- If this product is used in an interlock circuit, provide multiple interlock circuits as a precaution against failure, and also perform regular inspections to confirm normal operation.
- Even when the instantaneous flow rate display is 0, if there is a minimal flow rate signal (including error), the integrating flow (integration count) may be displayed. When it becomes a problem in that the integrating flow is measured in a state that the flow rate display is 0, use the start/stop function in the integrating flow measurement if required.

2. Maintenance and inspection

⚠ CAUTION

- Before conducting maintenance, turn the power OFF, stop the supply of compressed air and make sure that there is no residual pressure.
 - Observe the conditions to ensure safety.
- Regularly inspect the product at least once a year to check that it operates correctly.
- Do not disassemble or modify, as this may cause malfunction.